



**Geryon**  
Security Revolving Doors  
Security Turnstiles

# Geryon security revolving doors and security turnstiles

Efficient  
Reliable  
Flexible

Secure areas require a reliable system for identifying and separating authorized persons. As these areas are usually representative of the building, a secure but at the same time transparent access solution is preferred.

## **Two product lines**

The Geryon product family comprises security revolving doors and security turnstiles. Security revolving doors are suitable both for the interior and for the entrance, whereas security turnstiles can be used for indoor or outdoor areas.

## **Geryon Security Revolving Doors SRD Security revolving door**

Owing to the high transparency grade of the glass elements and a wide variety of colours for the metal parts, all models elegantly blend in with their surroundings. A sophisticated sensor system in compliance with the latest standards prevents users from being injured. Depending on the security requirements, the door may be equipped with a contact mat,

scales or internal monitoring. Other variants are reinforced bullet- and burglar-resistant designs, which are certified according to standards RC2 and RC3 respectively. Options like a rotating unit with emergency exit function<sup>1</sup> or a night closure complete the product range.

## **Geryon Security Turnstiles STS (Security Turnstile)**

For this three-winged unit you may either choose U-shaped stainless steel bars or acrylic glass elements for the door wings. Developers aimed to use as little metal as possible in the door design in order to achieve the highest possible level of transparency. The aesthetic design and the low diameter make STS especially suitable for indoor and outdoor areas.

<sup>1</sup> Individual approval required (responsible building authority)



## For secure entry to:

- Sensitive areas in administrative buildings, industrial premises, government agencies and ministries
- Banks and financial institutions
- Data and research centres
- Staff entrances at airports
- Nuclear power plants

### **Geryon Security Revolving Doors SRD**

Throughput rate = up to 20 per minute

Security level = ●●●●○

Comfort = ●●●●○

### **Geryon Security Turnstiles STS**

Throughput rate = up to 20 per minute

Security level = ●●●●○

Comfort = ●●●●○



# Advantages of Geryon Security Revolving Doors and Turnstiles

## Options for all security requirements

### Geryon SRD Security Revolving Doors

- Users cannot become stuck thanks to end point locking
- Safety sensor system according to DIN EN 16005
- Standard version has IR sensor system
- Versions with resistance classes RC2 and RC3
- All-glass units with underfloor drive
- Option with approved emergency exit column
- Option with in-built scales with weight limits or actual weight
- Option with night closure
- Option with optical separation using SRD Vision

### Geryon STS Security Turnstiles

- Users cannot become stuck thanks to end point locking
- Optional U-shaped stainless steel bars or acrylic glass elements instead of straight bars



Barrier-free access can also be provided by the arrangement of hinge doors or sliding doors at the side.

# The ideal solution for any access point



Units arranged diagonally for narrow passages – multiple units for staff access at an airport

Flexible integration – security revolving door in a historic setting



Double unit in polished stainless steel design

Stylish solution for installation indoors – security turnstile with acrylic glass barrier elements







# SRD Vision – first-rate access security

**Optional optical individual access control for maximum safety.**

Sensitive areas in particular place increased security demands on access control. The SRD Vision optical separation system, which is integrated into the ceiling, reliably and securely detects whether there is more than one person within a revolving door and allows or denies passage as is appropriate. The special thing about SRD Vision is that it possible to select it both for the three-leaf and four-leaf models.

**Application areas:**

- Banks/insurance companies
- Prisons
- Government buildings
- Airports
- Power plants
- Laboratories
- Data centres
- Office blocks
- and many more

**SRD VISION**  
The watchful eye



Light beam shows the SRD Vision detection area.

# The SRD Vision option – the advantages at a glance:

- False acceptance rate (FAR) <1%
- False rejection rate (FRR) <1.6%
- For three-leaved and four-leaved models (rotary cycle 120° and 180° respectively)
- Can be operated in two directions
- Inside diameter ranging from Ø1,800 mm to Ø2,500 mm
- Passage heights ranging from 2,300 mm to 2,900 mm
- No modification of the floor structure is necessary
- Retrofitting possible for security revolving doors with corresponding dimensions (except for Geryon SRD-S01 with glass ceiling) with a passage height of 2,300 mm or higher
- Unaffected by extraneous light
- Evaluation unit is suitable for remote maintenance
- Passage rate with SRD Vision remains at a high level
- No risk of people becoming trapped during power failure (automatic, self-monitored set-up of the unit after power is restored)

**Please ask for our fact sheet!**



## Separation process

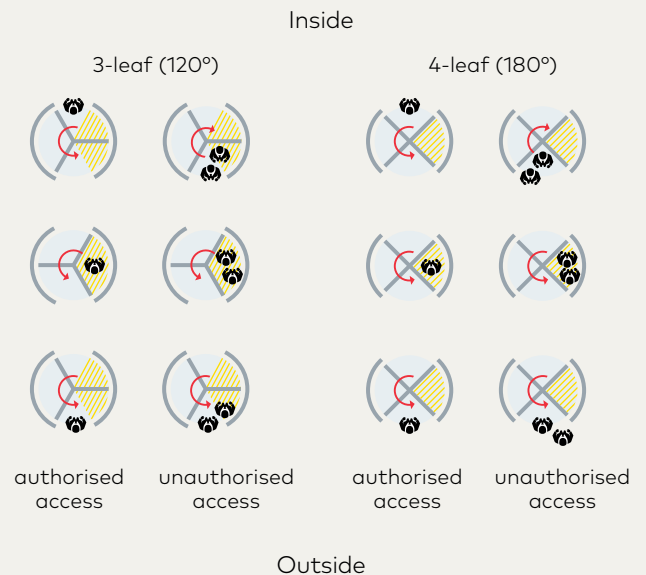

# Geryon security revolving doors



Basic equipment	
<b>Construction</b>	Outside diameter
	Total height
	Passage height
	Upper part of body
	Number of door wings
<b>Body</b>	Rotary cycle
	Side panels
	Thermal separation
	Safety strips
	Top cover
<b>Rotating unit</b>	Maintenance openings
<b>Finish</b>	
<b>Function</b>	
	In the event of a power failure
<b>Electrical components</b>	
<b>Installation</b>	

SRD-E01	
	1500 – 2000 (standard spacing 100).
	2300
	2100
	200
	3 or 4
	120° or 180° (Ø 1800 and larger).
	With glass panel, alternatively metal-clad.
	In facade level.
	On opposite closing edges.
	Raw aluminium plate, dustproof.
	Two, in the lower ceiling plate.
	Framed in T40 light metal profiles.
	With sealing brushes.
	Black U-shaped handles.
	Horizontal and vertical safety strips on the door leaves.
	Powder-coated in a RAL colour.
	PR-1 position control drive for automatic access control.
	Started by manually pushing door after release signal.
	Sensor system in the ceiling monitors the intermediate segment, incl. emergency release button.
	End point locking system, default can be set to turn freely or lock.
	Two emergency stop switches.
	The control unit is integrated into the unit.
	Power supply 100-130, 60 Hz or 220-240 VAC, 50 Hz.
	Standby power 60 VA.
	On finished floor level (FFL).

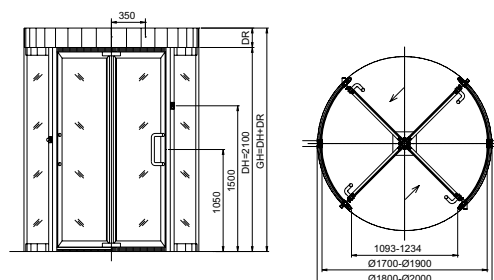

All dimensions in mm





### SRD-C01

1520 – 2020 (standard spacing 100).
2300
2100
200
3 or 4
120° or 180° (Ø 1820 and larger).
Metal-clad with steel or stainless steel sub-structure, alternatively with glazing.
–
On opposite closing edges.
Raw aluminium plate, dustproof.
Two, in the lower ceiling plate.
Framed in T56 light metal profiles.
With sealing brushes.
Black U-shaped handles.
Horizontal and vertical safety strips on the door leaves.
Powder-coated in a RAL colour.
PR-1 position control drive for automatic access control.
Started by manually pushing door after release signal.
Sensor system in the ceiling monitors the intermediate segment, incl. emergency release button.
–
End point locking system locked.
Two emergency stop switches.
The control unit is integrated into the unit.
Power supply 100-130, 60 Hz or 220-240 VAC, 50 Hz.
Standby power 60 VA.
On finished floor level (FFL).

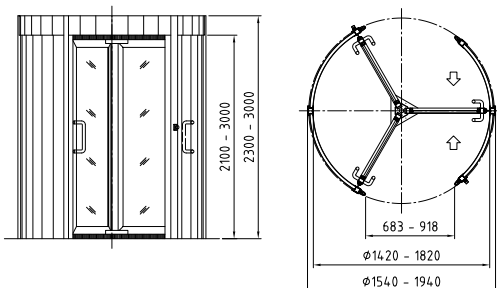

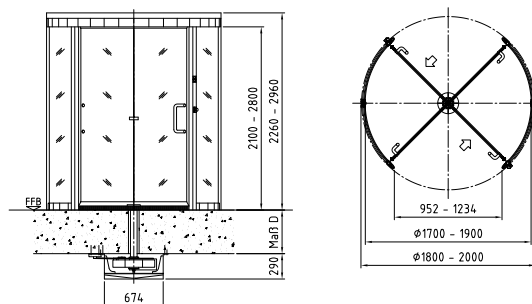

### SRD-S01

1500 - 2000 (standard spacing 100).
2260
2100
–
3 or 4
120° or 180° (Ø 1800 and larger).
With glass panel and filigree profiles, glass ceiling made of laminated safety glass.
In facade level.
On opposite closing edges.
Laminated safety glass ceiling.
–
T25 without centre column or profile, toughened safety glass.
With sealing brushes.
Black U-shaped handles.
Horizontal and vertical safety strips on the door leaves.
Powder-coated in a RAL colour.
PR-1 position control drive for automatic access control (underfloor).
Started by manually pushing door after release signal.
Sensor system in the ceiling (centre cross beam) and 1-zone contact mat/s monitor the intermediate segment/s (observe the restricted installation possibility for the sensor system), incl. emergency release button.
–
End point locking system, default can be set to turn freely or lock.
Two emergency stop switches.
Subsurface mounted control system.
Power supply 100-130, 60 Hz or 220-240 VAC, 50 Hz.
Standby power 60 VA.
On finished floor level (FFL), underfloor drive.



# Options (depending on unit type)

	SRD-E01	SRD-C01	SRD-S01
<b>Construction</b>			
Increase passage height.	•	•	•
Increase upper part of body.	•	•	
Resistance class RC2.	•	•	•
Resistance class WK3.		•	
Underfloor suspension for fixing drive to the raw ceiling.	•	•	Standard
Water tray or waterproof cover of outer part of body, made of light metal.	•	•	
Night closure outside, manual.	•	•	•
Motor for night closure.	•	•	
Monitoring of night closure, notification of status closed or closed and locked.	•	•	•
T25 rotating unit, all-glass version.	•		Standard
T56 rotating unit emergency exit function with manually foldable door leaves on centric bearings (Ø 1800 and larger).	•		
Stainless steel handle horizontal or vertical, installed on door leaf.	•	•	•
Floor element in stainless steel for installation in advance.	•	•	•
Stainless steel plate, may be perforated, to apply floor covering; alternatively waterproof wooden board.	•	•	•
Stainless steel plate for floor element.	•	•	•
Clamping rail for fixing on-site sealing foil, measure X = 150 or larger.	•	•	•
Coir mats or black rubber mats (optionally equipped with arrow) or carpet as cleaning zone.	•	•	•
<b>Finish</b>			
AISI 304 stainless steel, satin finish or S8 mirror polished.	•	•	•
Finish anodized C0 and C31-35 (E6).	•	•	•
<b>Function</b>			
Automatic starting after entering the security door and after release signal.	•	•	•
<b>Electrical equipment</b>			
Various consoles.	•	•	•
Push button for manual single release.	•	•	•
Electrical key-operated push button.	•	•	•
OPL 01 operating panel, functions can be chosen freely.	•	•	•
Signal device.	•	•	•
Weight control.	•	•	
Contact mat for monitoring intermediate segment, on SFL or in FFL.	•	•	•
Emergency stop switches with seal cap, instead of the existing ones. 	•	•	•
Pre-sensors for heavy rotating units, for additional safeguarding of persons requiring special protection. 	•	•	•
Lighting by 2 to 4 LEDs.	•	•	
<b>Security level: SRD</b>			
Basic security is achieved by adequate compartment size, light sensors in intermediate segment and card reader for access control.			

	Passage segment	Inter-mediate segment
<b>Enhanced security is achieved by</b>		
Contact mat (1 zone).		•
Rotating unit scales.		•
Actual weight scales including rotating unit scales.	•	•
Scales with weight limit including rotating unit scales.	•	•
Biometrics outside SRD.	•	
SRD Vision (not for RDR-S01).	•	•

The security level depends on the object to be protected and trust in the authorized users.

All dimensions in mm  Safety device

# SRD connections

Example of 200 wall connection, top

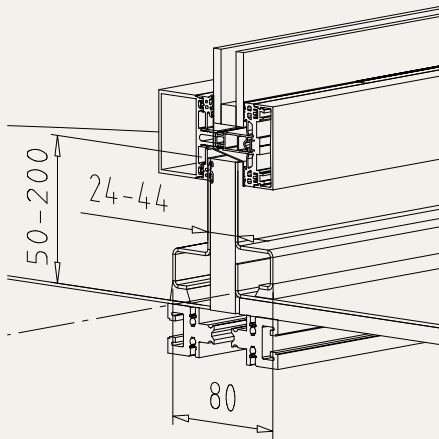

Example of 200 wall connection, side

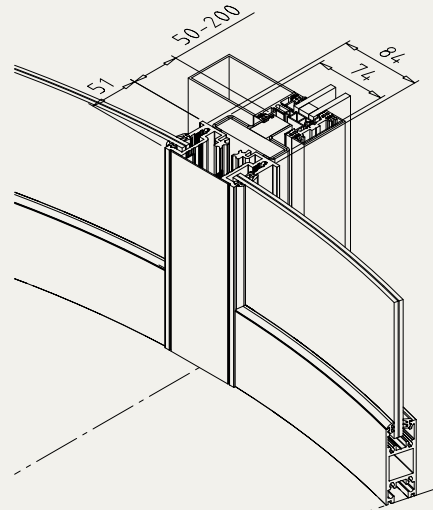

Underfloor drive

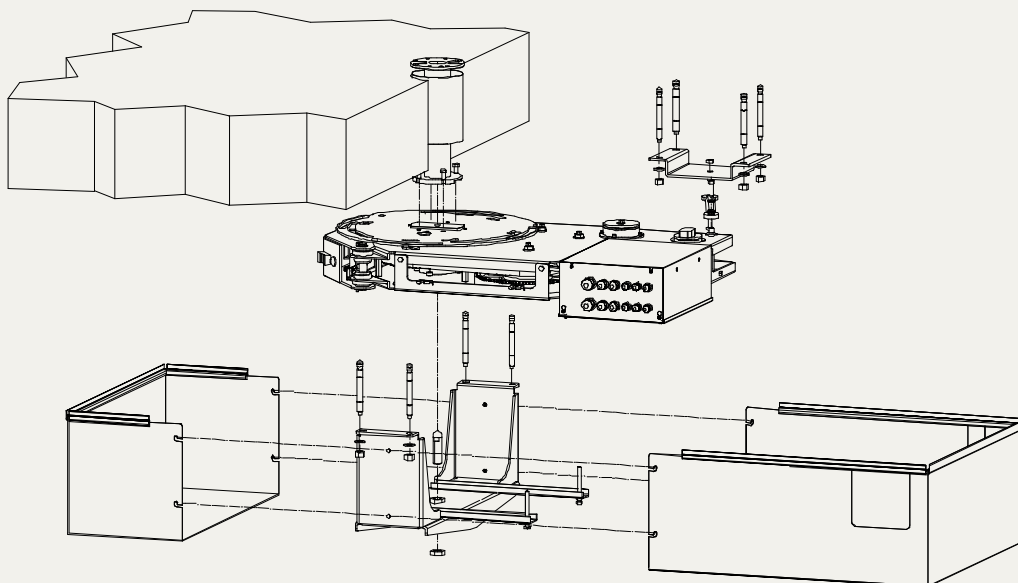

All dimensions in mm



# SRD rotating units

## Rotating unit T25 – 120°

Outside diameter:

Ø1500 - Ø2000

1. Toughened safety glass
2. Safety strip
3. Sealing brush
4. Safety strip on both sides

Rotating unit without centre column.

Profile depth 25 mm.

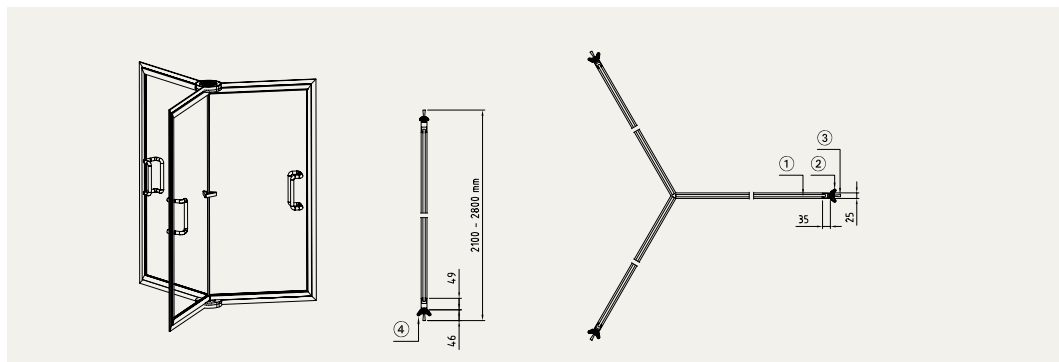

## Rotating unit T25 – 180°

Outside diameter:

Ø1800 - Ø2000

1. Toughened safety glass
2. Safety strip
3. Sealing brush
4. Safety strip

Rotating unit without centre column.

Profile depth 25 mm.

Safety strips on one side.

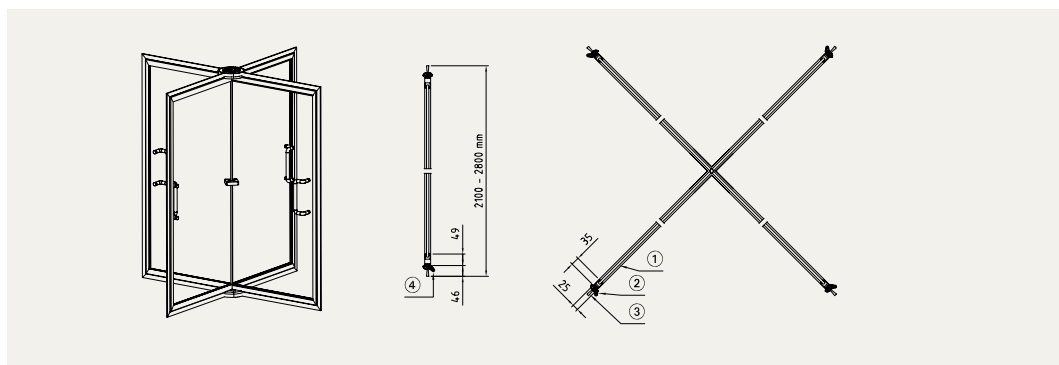

## Rotating unit T40 – 120°

Outside diameter:

Ø1500 - Ø2000

1. Laminated safety glass
2. Safety strip
3. Sealing brush
4. Safety strip on both sides

Rotating unit with centre column.

Profile depth 40 mm.

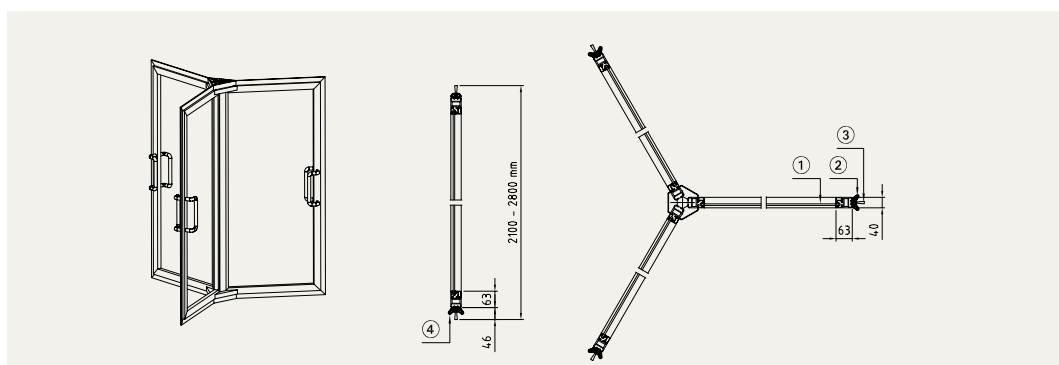

## Rotating unit T40 – 180°

Outside diameter:

Ø1800 - Ø2000

1. Laminated safety glass
2. Safety strip
3. Sealing brush
4. Safety strip

Rotating unit with centre column.

Profile depth 40 mm.

Safety strips on one side.

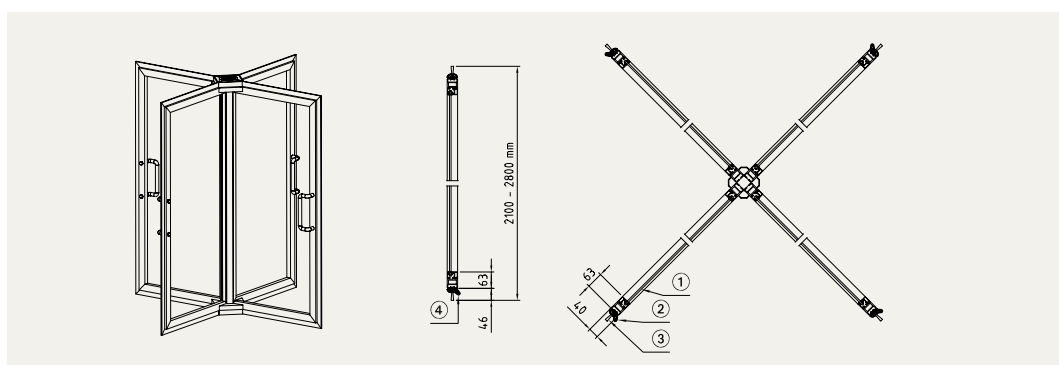

All dimensions in mm

**Rotating unit T56 – 120°**

**Bullet-resistant**

Outside diameter:

Ø1540 - Ø2000

- 1. BR4 glazing
- 2. Safety strip
- 3. Sealing brush
- 4. Safety strip on both sides

Rotating unit with centre column, bullet-resistant.  
Profile depth 56 mm.

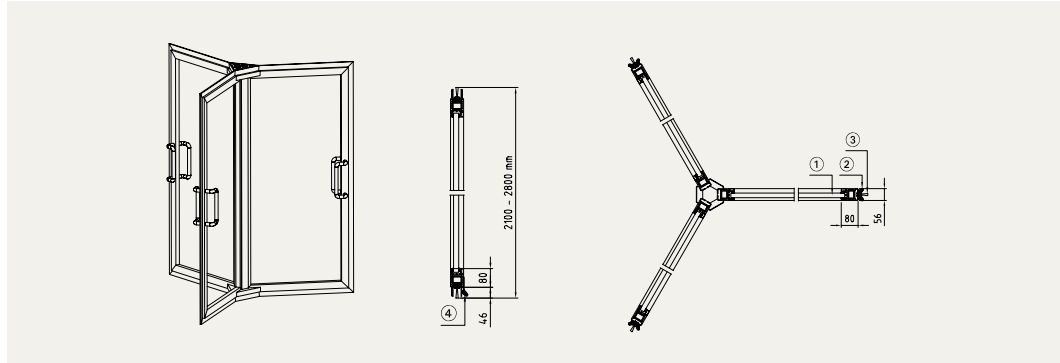

**Rotating unit T56 – 180°**

**Bullet-resistant**

Outside diameter:

Ø1800 - Ø2000

- 1. BR4 glazing
- 2. Safety strip
- 3. Sealing brush
- 4. Safety strip

Rotating unit with centre column, bullet-resistant.  
Profile depth 56 mm.

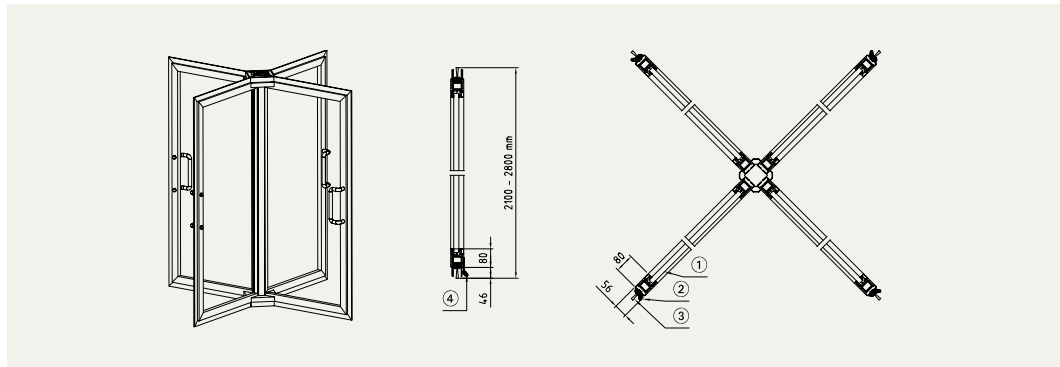

**Rotating unit T56 – 120°**

**Escape route**

Outside diameter:

Ø1800 - Ø2000

- 1. Laminated safety glass
- 2. Safety strip
- 3. Sealing brush
- 4. Safety strip on both sides

Rotating unit with centre column and emergency exit function.  
Profile depth 56 mm.

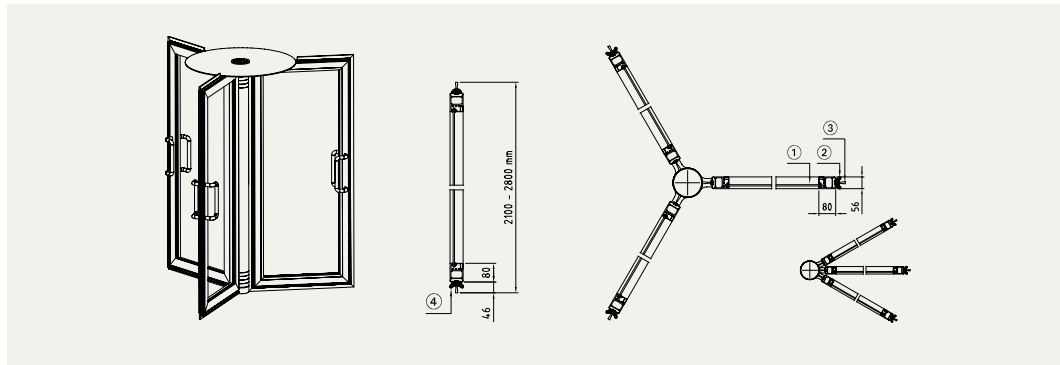

**Rotating unit T56 – 180°**

**Escape route**

Outside diameter:

Ø1800 - Ø2000

- 1. Laminated safety glass
- 2. Safety strip
- 3. Sealing brush
- 4. Safety strip

Rotating unit with centre column and emergency exit function.  
Profile depth 56 mm.

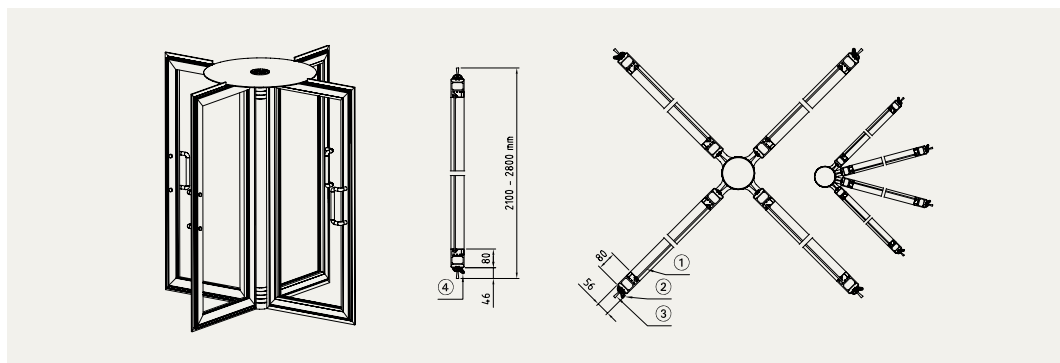

All dimensions in mm

# Floor elements for SRD types

## Floor element without stainless steel plate for sealing

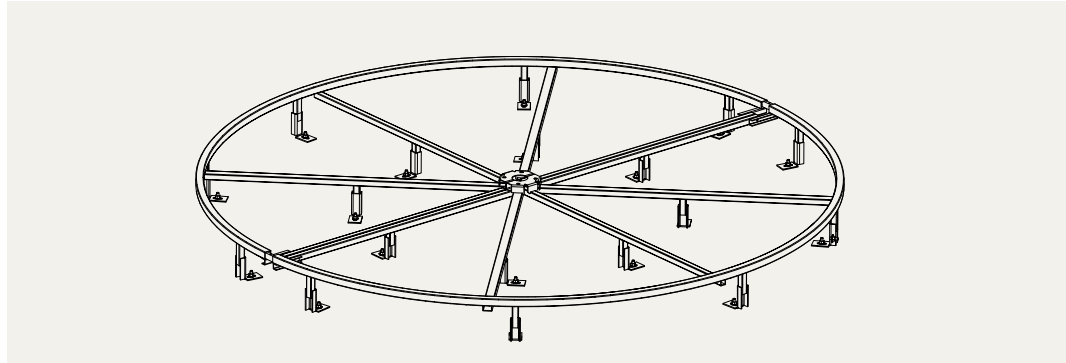

## Floor element with stainless steel plate for sealing, measure X = 150 or larger

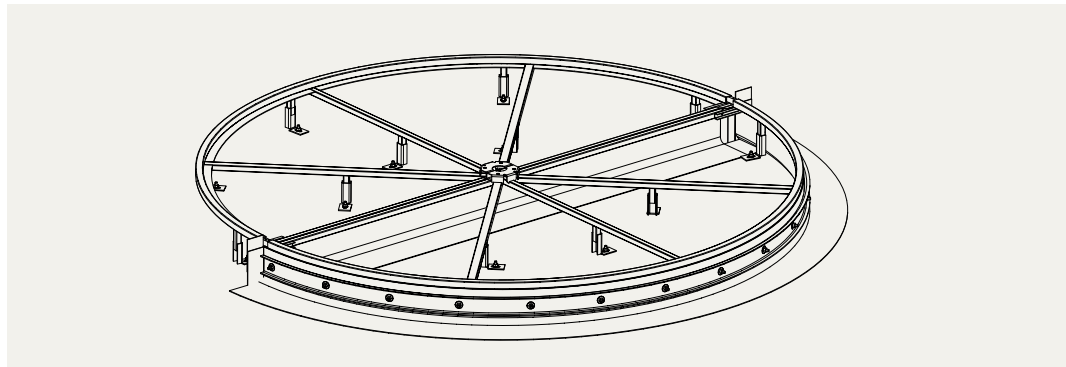

### Detail: floor element with sealing foil at the outer radius, measure X = 150 or larger

1. Sealing foil 300 mm (self-adhesive) or on-site foil
  2. Stainless steel fastening clamp
  3. Continuous stainless steel ring (25 mm)
  4. Clamping rail with M8 welding stud
  5. Adjusting plate
- x: installation depth OK FFL to OK SFL

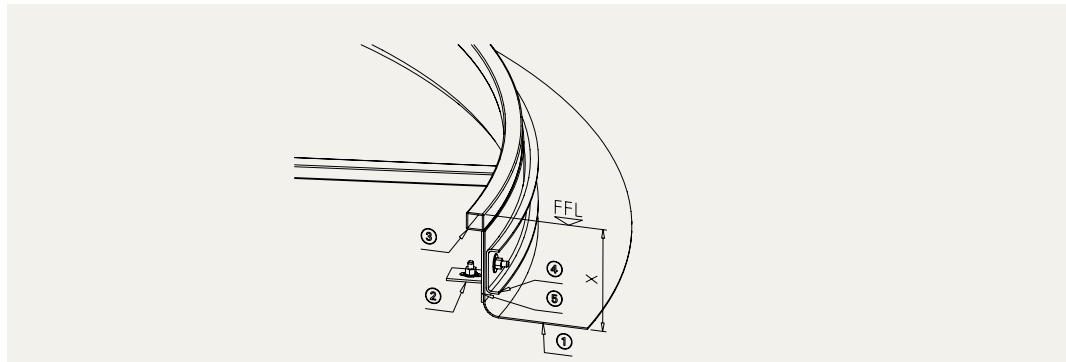

### Detail: floor element with sealing foil in facade axis

1. Sealing foil 300 mm (self-adhesive) or on-site foil
  2. Stainless steel fastening clamp
  3. Stainless steel strut for connection and support
  4. Floor bearing fixing
  5. Adjusting plate
- x: installation depth OK FFL to OK SFL

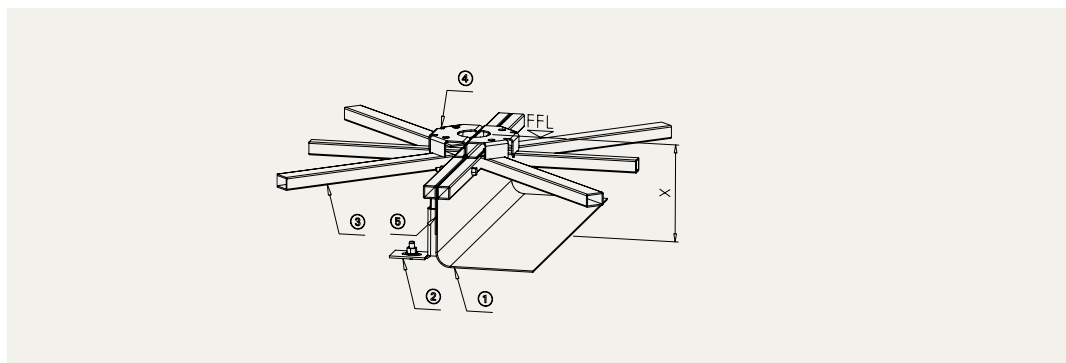

All dimensions in mm



**Floor element with drive box for floor pit, measure X = 350 or larger**

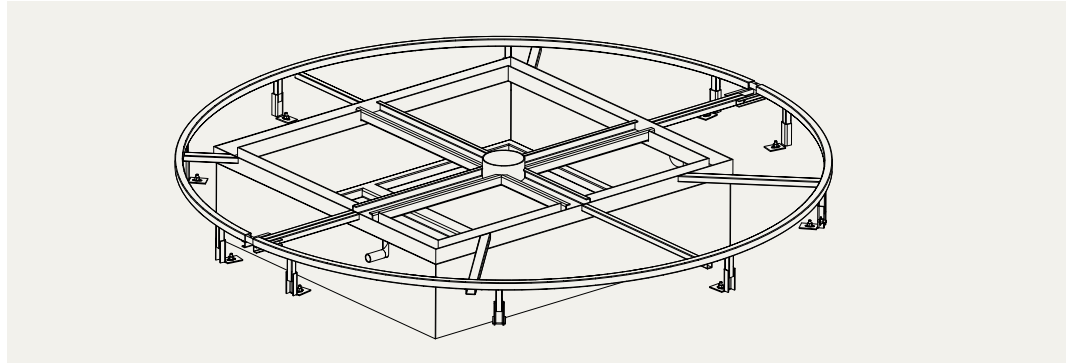

**Floor element with scales 180°, measure X = 90 or larger**

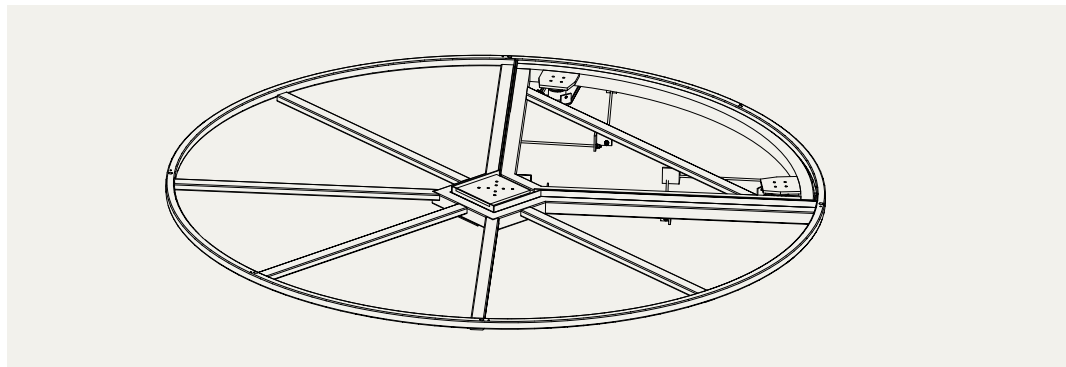

**Stainless steel plate for floor element**

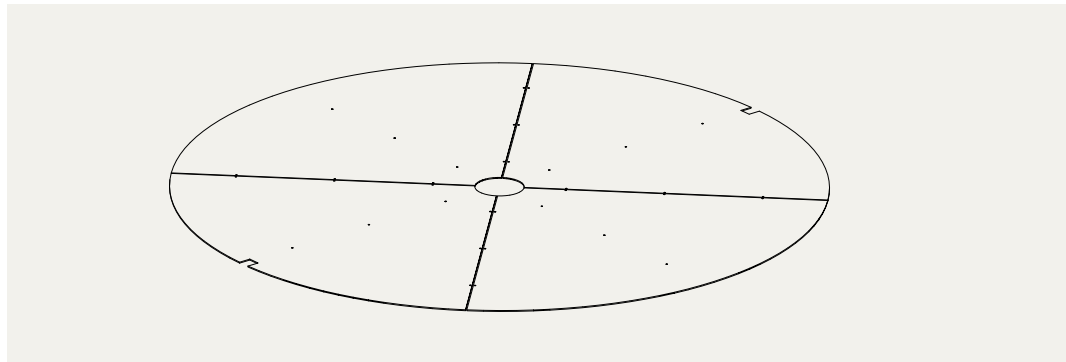

**Stainless steel plate for floor element – perforated (for drainage)**

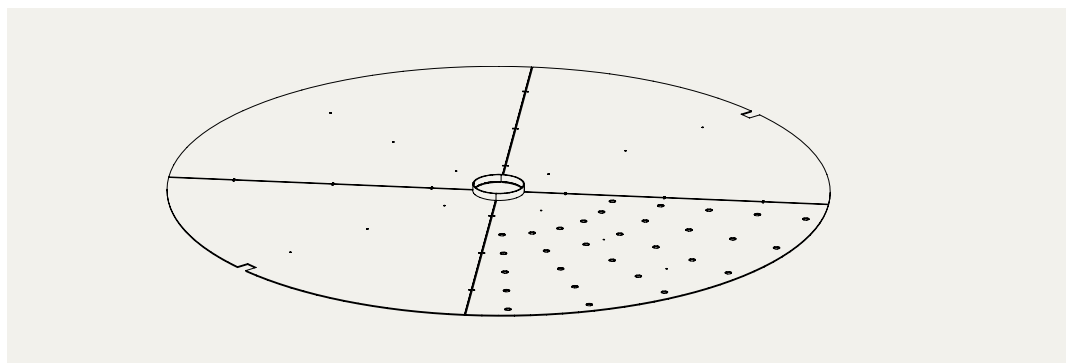

All dimensions in mm

# Alternative bodies for SRD types

Body with floor element

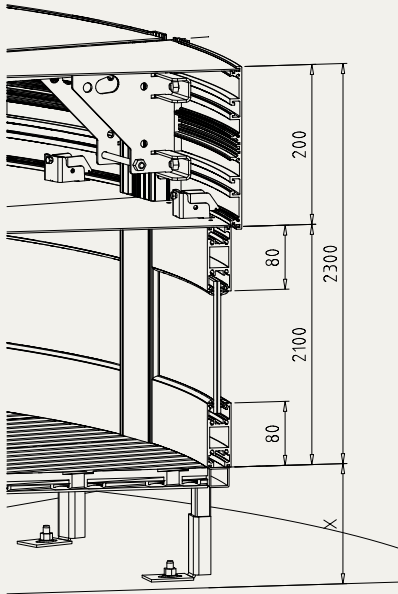

Body with dustproof cover

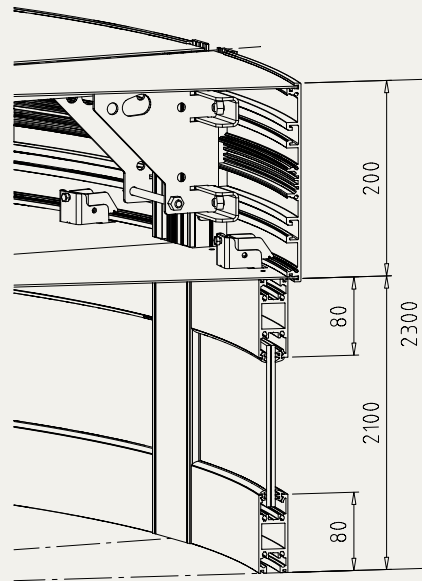

Body with waterproof cover

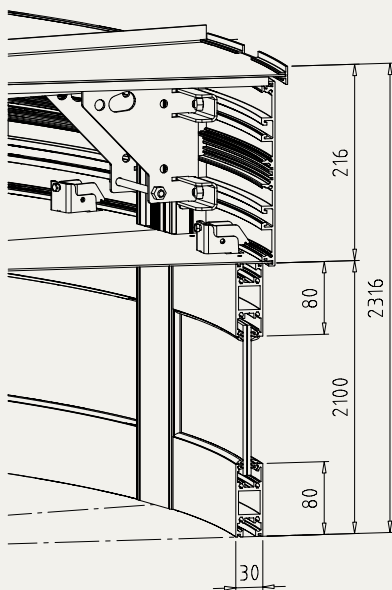

Body with water tray and spout

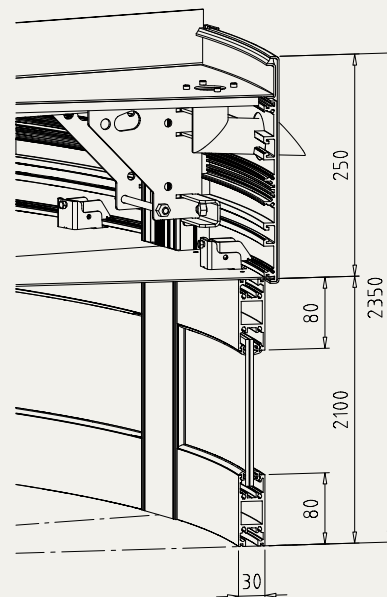

All dimensions in mm

**Body with night closure**

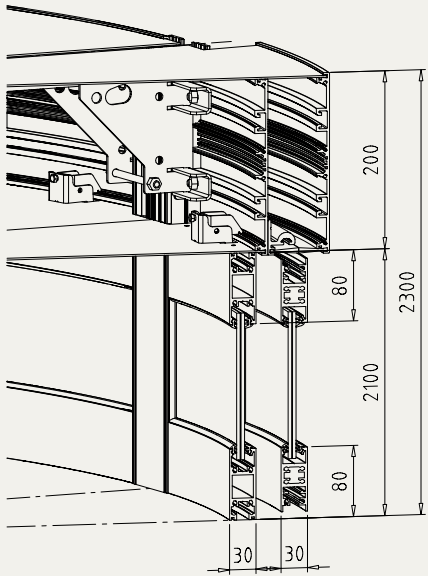

**Body – glass ceiling with frame**

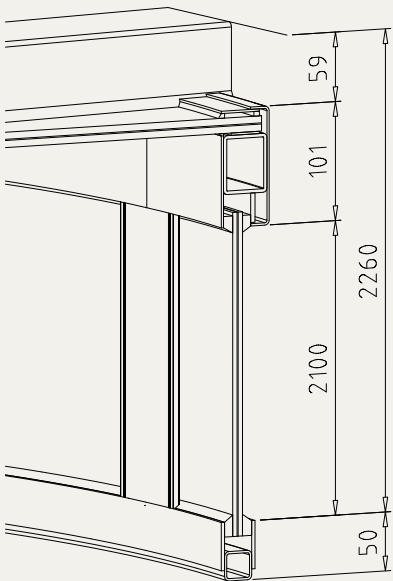

**Body – glass ceiling without frame**

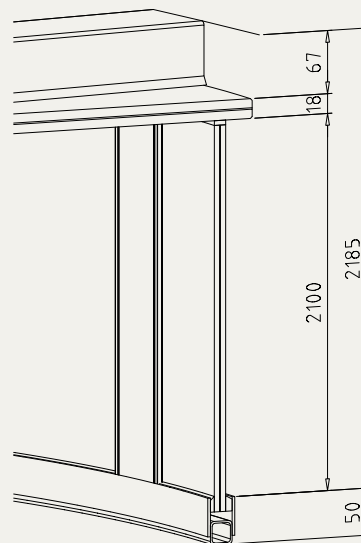

If the SRD-S01 is installed in the facade axis, we recommend a roof is provided on site for drainage



# Geryon security turnstiles



<b>Standard unit</b>	
<b>Construction</b>	Outside diameter
	Total height
	Passage height
	Upper part of body
	Rotating unit
<b>Body</b>	Side panels
	Top cover
	Maintenance openings
	Barrier element
<b>Finish</b>	
<b>Function</b>	
<b>Electrical equipment</b>	
<b>Installation</b>	

<b>STS-S02</b>	
1500	
2275	
2075	
200	
120°, tubular column Ø 89 with sets of 7 U-shaped Ø 27 crossbars made of glossy AISI 304 stainless steel.	
With 8 mm laminated safety glass.	
Raw aluminium plate, dustproof.	
Two, in the lower ceiling plate.	
Rectangular light metal profiles.	
Aluminium elements powder-coated in a RAL colour.	
Type 2*	
The control unit is integrated into the unit.	
Power supply 110–230 VAC, 50/60 Hz.	
Standby power 20 VA.	
On finished floor level (FFL).	

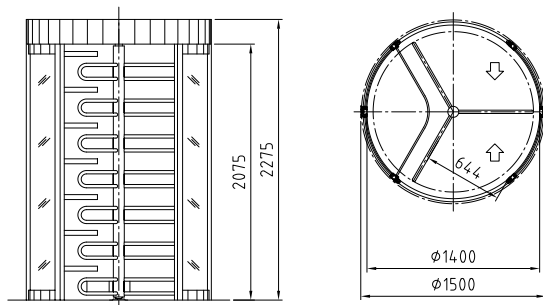

\* Type 2: power-assisted motion, servo-positioning drive/electrically controlled in both directions (behaviour in event of power failure can be selected for each direction: free or blocked)

# Options for STS-S02 Security Turnstile

## Construction

Rotating unit made of acrylic glass.  
200 wall connection.

## Finish

Body: stainless steel satin finish.

## Electrical components

Various consoles.

Push button for manual single release, integrated in stainless steel console.

OPL 05 operating panel.

Signal device in stainless steel console consisting of 2 lights red/green.

Additional boards to expand the existing inputs/outputs.

Lighting by 2 LEDs.

## STS rotating units

### Stainless steel rotating unit – 120°

Inside diameter: Ø1400

1. Stainless steel tube, electropolished
2. Stainless steel bar, electropolished

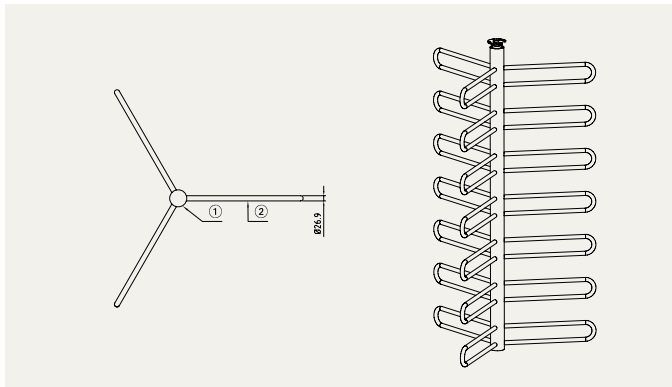

### Acrylic glass rotating unit – 120°

Inside diameter: Ø1400

1. Metal cladding in unit colour
2. Acrylic glass bar, smooth/with marking optionally with stainless steel inlay

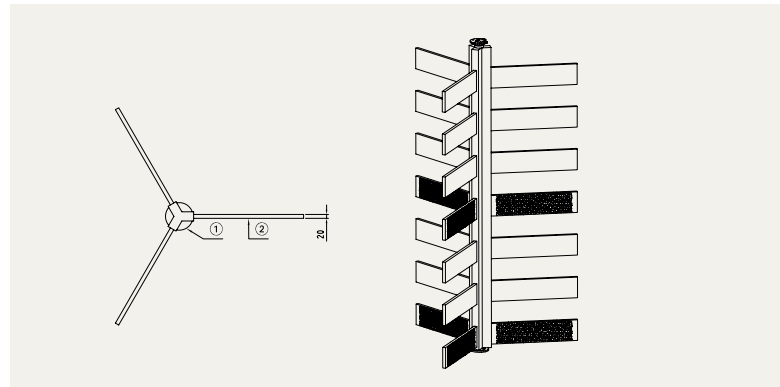

## Consoles

Console 1  
plastic in RAL 9006

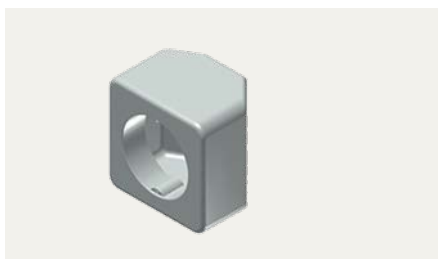

Width 94  
Height 94  
Depth 65

Console 4  
Stainless steel  
Semi-gloss smooth finish



Width 118  
Height 93  
Depth 60

Console 5  
Stainless steel  
Semi-gloss smooth finish

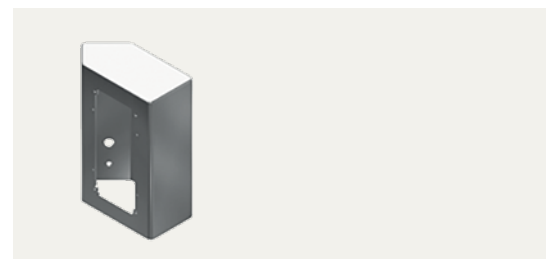

Width 118  
Height 164  
Depth 60



**Door  
Hardware**



**Electronic  
Access & Data**



**Mechanical  
Key Systems**



**Lodging Systems**



**Entrance  
Systems**



**Interior Glass  
Systems**



**Safe Locks**



**Service**

**dormakaba**  
**International Holding AG**  
Hofwisenstrasse 24  
CH-8153 Rümlang  
T +41 44 818 90 11  
info@dormakaba.com  
www.dormakaba.com