



Orthos

Personal Interlocks

Versatile Orthos Personal Interlocks

Effective
Precise
Secure

Top security is not just a matter of checking whether a user has authorisation to enter. The highest degree of separation and authorisation checking must be achieved. Orthos electronically monitored security interlocks meet the highest security demands and provide optimal protection for sensitive building areas.

Versatility

The Orthos product series comprises all kinds of shapes, including round or rectangular personal interlocks for single passage or interlocks with a set of doors in a row, which can only be passed through in one direction.

Orthos round or cubic PIL Personal Interlocks

The degree of separation can be accomplished by means of body weight, sensors or an additional check point for identification in the middle of the interlock. Depending on the security requirements, the interlock may be equipped with contact mats, scales or internal monitoring. Alternative versions for high-security areas include bullet- and burglar-resistant designs. The different variants are certified from RC2 up to RC4.



Personaleingang



Advantages of Orthos Personal Interlocks

Maximum security for sensitive areas.

Orthos PIL round or cubic Personal Interlocks

- High level of security owing to contact mats
- Additional security through installation of scales with weight limit or actual weight
- Resistance classes RC2, RC3 and up to RC4 for cubic interlocks
- Optional wings and folding wing doors and automatic locking
- Optional fire door
- Optional emergency exit function
- Optional bullet- and burglary-resistance
- Elegant glass units
- Quiet, low-noise operation
- Minimal space requirement



Interlocks with automatic drives and an appropriate passage width offer a barrier-free solution.

The ideal solution for any access point



Single unit – minimal space requirement thanks to compact design



Identification prevents misuse

With integrated biometric system for maximum security

All-glass multiple unit in polished stainless steel design



For maximum security in:

- Computer centres
- Research centres
- Nuclear power plants
- Banks and financial institutions
- Secured areas of government buildings, company buildings and airports

Orthos round or cubic Personal Interlocks

Throughput rate = 3 to 5
per minute

Security level = ●●●●●●

Comfort = ●●●○○○





Orthos Personal Interlocks



Standard units

Construction

Outside diameter	1020, 1120, 1220, 1320, 1420, 1520, 1620
Passage width	520, 580, 650, 710, 780, 840, 910
Total height	2300
Passage height	2100
Upper part of body	200

Body	Resistance class
	Side panels
	Interior

Sliding doors

Finish

Function

Electrical equipment

Installation

PIL-S01

RC2 or without available.
With glass panel, alternatively metal-clad.
Including black rubber floor covering.

Made of light metal profiles with curved glass,
flush-mounted outside.

Powder-coated in a RAL colour.

Door leaves with locking system. Default position inside and outside closed.
Automatic opening and closing of both door leaves consecutively.
PMA emergency release switch inside the interlock, opens the outer door.
Interior with surface light scanner for relaying, including 1-zone contact mat with black rubber floor covering.
Light curtain for contactless protection. Integrated in the faceplate of the outside radius on both sides.
Behaviour of the sliding doors in the event of a power failure can be freely selected. Standard setting: inside closed and locked, outside open.
Behaviour of the sliding doors in the event of a power failure for burglary- and bullet-resistant option: outside closed and locked, inside open. PMA is replaced by a manual unlocking device inside the interlock.

Network-compatible ETS 21 CAN bus control unit integrated in the unit.

Power supply 230 VAC, 50 Hz.

On stainless steel floor element with guide rail for sub floor level SFL, measure X = 70 - 79 mm.

The ambient conditions must be checked for outdoor installation.

PIL-C01

1020, 1220

550, 680

2400

2100

300

WK2, WK3 or without available.
Metal-clad side panels with steel substructure.
Lighting included (LED, 30,000 h service life).

Made of light metal profiles with curved glass,
flush-mounted outside. Design according to chosen resistance class.

Powder-coated in a RAL colour.

Door leaves with locking system.
Safety strips at the main closing edges that move with the door.
Default position inside and outside closed.
Automatic opening and closing of both door leaves consecutively.
PMA emergency release switch opens the outer door.
Interior monitored by sensor system (light scanner and 1-zone contact mat with black rubber floor covering).
Behaviour of the sliding doors in the event of a power failure can be freely selected. Standard setting: inside closed and locked, outside open.
Behaviour of the sliding doors in the event of a power failure for burglary- and bullet-resistant option: outside closed and locked, inside open. PMA is replaced by a manual unlocking device inside the interlock.

Network-compatible ETS 21 CAN bus control unit integrated in the unit.

Power supply 230 VAC, 50 Hz.

On floor element for sub floor level SFL, measure X = 70 mm.

The ambient conditions must be checked for outdoor installation.

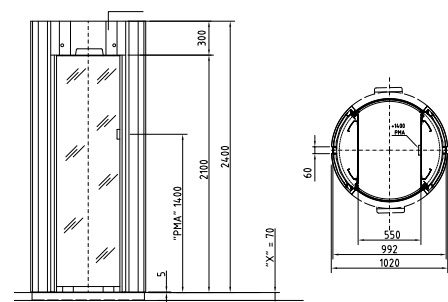
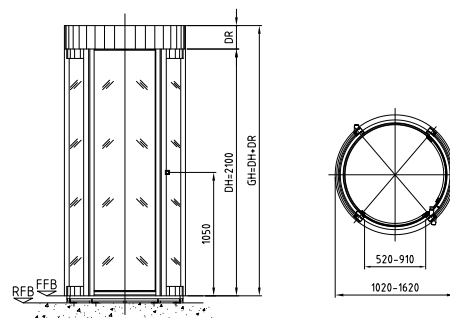

All dimensions in mm

Options (depending on unit type)

Note: Increase access security using a 2-zone contact mat.
Biometric verification and weight detection are possible.

	PIL-S01	PIL-C01
Construction		
Increase passage height.	•	
Increase upper part of body.	•	•
Thermal separation of body side panels in axis.	•	
Wall connection.	•	•
Manual unlocking devices for inner or outer door, installed on outer side of body.		•
Monitoring of sliding door for notification of status closed and locked.	•	•
Finish		
Stainless steel satin finish.	•	•
Anodised CO and C31-35 (E6).	•	
Silver anodised CO instead of powder-coated according to RAL colour.	•	•
Electrical equipment		
Consoles (1, 2 and 3) made of plastic or aluminium in colour of unit or in RAL 9006, also available as semi-gloss stainless steel with a smooth finish.	•	•
Consoles 4 and 5 made of semi-gloss stainless steel with a smooth finish.	•	•
Push button for manual single release.	•	•
Electric key-operated push button to release unit.	•	•
OPL 01 operating panel, functions can be chosen freely.	•	•
Magnetic contact for monitoring maintenance openings or ceiling plate.	•	•
Signal device consisting of 2 lights red/green.	•	•
Contact mats including rubber flooring with studded surface.	•	•
Light curtain for contactless protection (see project-specific risk assessment).	Standard	•
PIB emergency release button, PMI, PMB emergency release switch.	•	•
Various weight readings for access control (actual weight or weight limits).	•	•
Lighting by 2 LEDs.	•	Standard
Additional board to expand the existing inputs and outputs.	•	•
Installation		
Wall frame for pre-installation.		•
Base frame for raised floor.	•	•
Floor element made of stainless steel for pre-installation.	Standard	•

Passage sequence, see page 18.

Security level according to equipment, see page 17.

Drawings of options, see page 15.

ETS 21: parameterisable, potential-free messages to be processed on site, see page 17.

Orthos Personal Interlocks



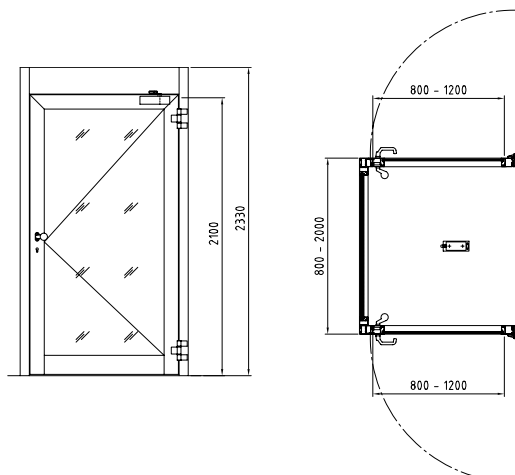

Standard unit	PIL-M01	
Construction	Upper section length	800 - 2000
	Passage width	800 - 1200
	Outer dimension	Depends on combination
	Total height	2330
	Passage height	2100
	Upper part of body	230
Body	Upper part of the body with dustproof covering and ceiling plate house the control and surveillance elements.	
	Outer door	Optional (hinge door, folding wing, sliding door, fire protection door) or on-site door.
	Inner door	Optional (hinge door, folding wing, sliding door, fire protection door) or on-site door.
Finish	Powder-coated in a RAL colour.	
Function	<p>Default position inside and outside closed.</p> <p>Release signals to activate the door from inside or outside provided on site.</p> <p>Release of the first door in entrance or exit direction. Release of the second door in entrance and exit direction, as soon as the first door has been automatically closed and locked.</p> <p>Interior with surface light scanner for relaying.</p> <p>Lighting can be installed.</p>	
Electrical equipment	ETS 21 CAN bus control unit integrated in the unit.	
Installation	With side walls on finished floor level FFL.	
	The ambient conditions must be checked for outdoor installation.	



All dimensions in mm

Orthos PIL-M01 options

Note: Level of access security can be increased using a 2-zone contact mat, additional light barriers, biometric verification, optical separation and weight detection. Increase convenience using swing door drives.

Construction	
Increase upper part of body.	
Side wall consisting of aluminium profile with 8 mm laminated safety glass.	
Side wall consisting of aluminium profile in WK2 with P4A glazing.	
Swing door consisting of aluminium profile with 8 mm laminated safety glass.	
Swing door consisting of aluminium profile in WK2 with P4A glazing.	
Smokeproof swing door with 8 mm laminated safety glass.	
Magnetic clamp (locking force 5000 N) in addition to electrical door opener for outer or inner door.	
Fire door, T30 (EI-30) or T90 (EI-90) made of primed steel plate with viewing window in F30 or F90.	
Folding wing door with continuous profile system and sealing. 10 mm toughened safety glass.	
Floor element made of stainless steel for pre-installation.	
Base frame for raised floor.	
Floor covering with green or grey round zone marking Ø 300 mm in centre of interlock.	
Watertight wooden base plate for floor covering, height = 10 mm.	
Black rubber flooring with studded surface, height 5 mm, to be glued to prepared floor or concrete.	
Function	
Electromechanical drive (with return spring) for swing door (not suitable for fire doors).	
Electromechanical drive (with return spring) for swing door. Suitable for fire doors.	
Pre-assembled finger protection textile to be used in the swing door hinge (with self-retraction). 	
Sensor strip (light curtain) on inside and outside of door leaf that moves with the door. 	
Fixed light curtain on folding wing door. 	
Integrated door closer, hidden within the frame of swing door instead of lintel installation.	
Emergency and escape route module.	
Emergency exit functions for hinge door and folding wing door.	
Electrical equipment	
Installation preparation for on-site components.	
Consoles 4 and 5 made of semi-gloss stainless steel with a smooth finish.	
Emergency release button with various functions (PMB, PIB, PMA, PMI).	
Push button for manual single release.	
Key-operated push button or switch prepared for on-site profile half cylinder to install in flush-mounted box/surface mount housing or console.	
OPL 01 operating panel, functions can be chosen freely.	
Various surface mount housings and installation frames.	
Door glass pane with alarm function (trip wire alarm system, alarm wire, glass breakage detector).	
Magnetic contact message «closed» according to VDS «C» or bolt contact message «locked» for on-site processing of the swing door.	
Magnetic contacts for monitoring the maintenance openings.	
Signal device consisting of 2 lights red/green.	
Surface light scanner integrated in upper part of the body for additional monitoring of complete interlock interior.	
Contact mats including rubber flooring with studded surface.	
Ramp rail for contact mat on finished floor level FFL, on entrance and exit side.	
Various weight readings for access control (actual weight or weight limits).	
Lighting by 2 or 3 LEDs.	
Additional boards to expand the existing inputs/outputs.	

Safety device

Passage sequence, see page 19.

Security level according to equipment, see page 17.

Drawings of options, see page 15.

ETS 21: parameterisable, potential-free messages to be processed on site, see page 17.

Zubehör

Console 1	Console 2	Console 3	Console 4	Console 5
Plastic in colour of unit or in RAL 9006	Aluminium in colour of unit or in RAL 9006	Aluminium in colour of unit or in RAL 9006	Stainless steel satin finish	Stainless steel satin finish

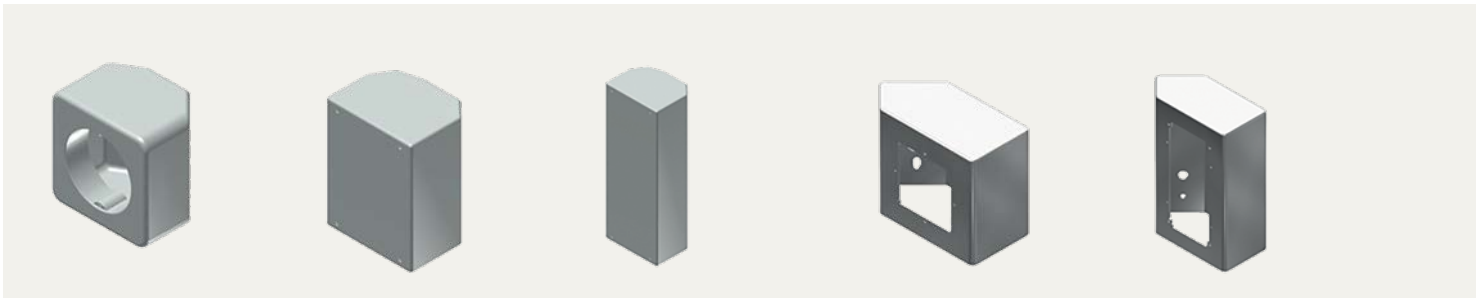

Width	94 mm	Width	140 mm	Width	140 mm	Width	118 mm	Width	118 mm
Height	94 mm	Height	180 mm	Height	365 mm	Height	93 mm	Height	164 mm
Depth	65 mm	Depth	110 mm	Depth	110 mm	Depth	60 mm	Depth	60 mm
PIL-C01		PIL-C01		PIL-C01		PIL-C01		PIL-C01	
PIL-S01		PIL-S01		PIL-S01		PIL-S01		PIL-S01	
PIL-M01		PIL-M01		PIL-M01		PIL-M01		PIL-M01	



Electric key-operated push button in console	Release button	Signal device	Key switch	OPL 05
PIL-C01	PIL-C01	PIL-C01	PIL-C01	PIL-C01
PIL-S01	PIL-S01	PIL-S01	PIL-S01	PIL-S01
PIL-M01	PIL-M01	PIL-M01	PIL-M01	PIL-M01

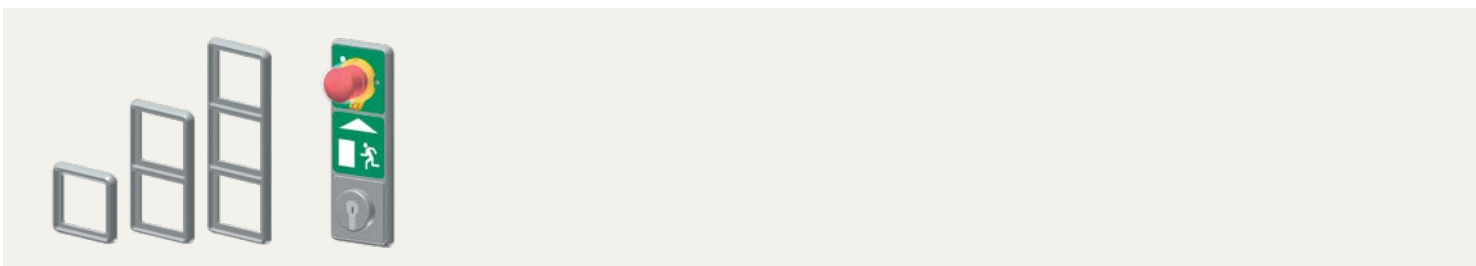

Frame for flush-mounting	Emergency escape route terminal
PIL-C01	
PIL-S01	
PIL-M01	PIL-M01

Security level according to equipment

Element	Degree of separation
Contact mat (1 zone)	--
Contact mat (2 zones)	low
Additional light barriers and light scanner	enhanced
Scales with one weight limit	increased
Scales with two weight limits	high
Scales, actual weight	very high
Scales, actual weight and biometrics	highest

ETS 21: parameterisable, potential-free messages to be processed on site

There are five potential-free feedback messages in the mother board:

- Ready for entry
- Passage entry
- Ready for exit
- Passage exit
- Error

Additional feedback messages can be added by using additional I/O boards.
Max. 6 potential-free messages for each additional I/O board.

For example:

- Blocked
- Generally released
- Emergency release switch
- Single release entry
- Single release exit
- Continuous release entry
- Continuous release exit
- Release disabled entry
- Release disabled exit
- Random generator on/off
- Random generator alarm
- Passage message entry
- Passage message exit
- Setup after power failure
- Setup from known position
- Ready for entry/exit
- Ready
- Home position
- Pulse for electromechanical counter
- Message service
- General error
- Error bus
- Cleaning inside
- Cleaning outside
- Single-door mode
- Sabotage inner door leaf
- Sabotage outer door leaf
- Interlock occupied
- Interlock occupied, both doors closed
- Inner door locked
- Outer door locked
- Pre-alarm
- Alarm
- Alarm suppression

Further messages available using parameterisation.

All parameters are described in detail in the online help for the control unit.

Passage sequence

Orthos PIL-S01 and -C01

Passage sequence with card reader outside (biometric check possible)

Default position: interlock is closed and locked.

- Person granted authorisation from card reader.
- Door is opened for authorised person.
- Entrance into the cabin.
- Door closes automatically.
- Inside the cabin additional identification and measuring systems will be activated if installed.
- Second door opens or person is rejected (leaves the interlock through the first door).
- The last opened door closes automatically (starting position).

Other passage sequences can be used (functions individually activated by ID card)

- automatic mode without centre reader
 - automatic mode with centre reader
 - comfort mode for disabled persons without centre reader
 - comfort mode for disabled persons with centre reader
 - material interlock
 - preferential mode entry or exit
 - single-door mode entry or exit
-

PIL-S01

PIL-C01

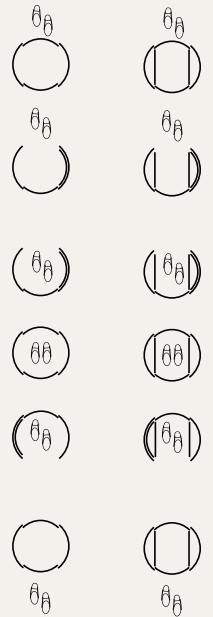

Orthos PIL-M01

with two hinge doors in basic version or with WK2, WK3 or T30/T90 (EI-30/EI-90) outer door

Passage sequence with card reader outside (biometric check possible)
Default position: interlock is closed and locked.

- Person granted authorisation from card reader.
- Authorised person opens door.
- Entrance into the cabin.
- Door closes automatically.
- Inside the cabin additional identification and measuring systems will be activated if installed.
- Person opens second door or is rejected (leaves the interlock through the first door).
- The last opened door closes automatically (starting position).

with hinge door outside and folding wing inside, suitable for escape routes

Passage sequence with card reader outside (biometric check possible)
Default position: interlock is closed and locked.

- Person granted authorisation from card reader.
- Authorised person opens door.
- Entrance into the cabin.
- Door closes automatically.
- Inside the cabin additional identification and measuring systems will be activated if installed.
- Second door opens automatically and the person leaves the interlock or the person is rejected (leaves the interlock through the first door).

Emergency escape route:

Triggered by emergency escape route terminal according to EltVTR or by fire alarm/hazard alert system. Inner folding wing door opens, outer hinge door has to be opened manually.

Emergency exit equipment according to DIN EN 179.

The customer or constructor has to apply for an "individual authorisation" from the highest building authority.

Other passage sequences can be used (functions individually activated by ID card)

- automatic mode without centre reader
- automatic mode with centre reader
- comfort mode for disabled persons without centre reader
- comfort mode for disabled persons with centre reader
- material interlock
- preferential mode entry or exit
- single-door mode entry or exit

PIL-M01

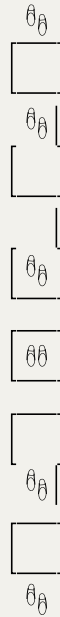

Installation examples

Orthos PIL-S01

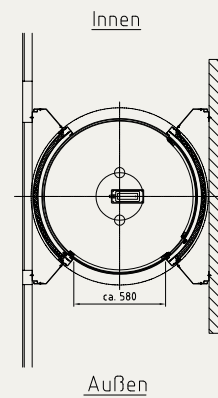
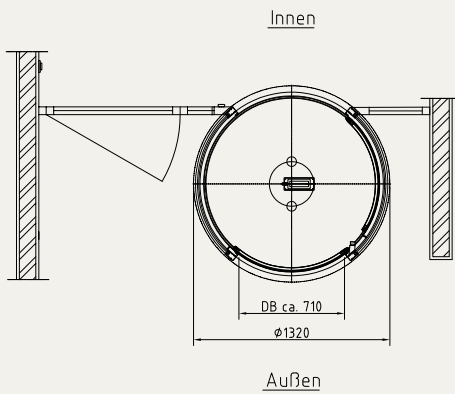
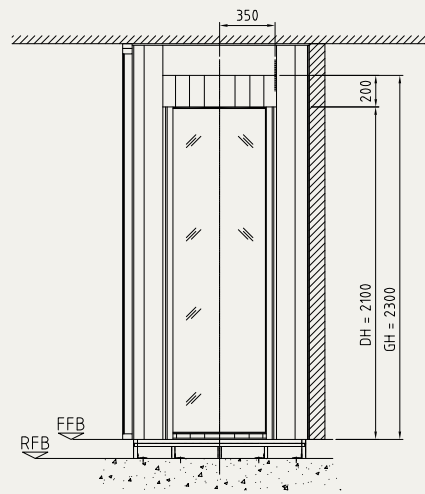
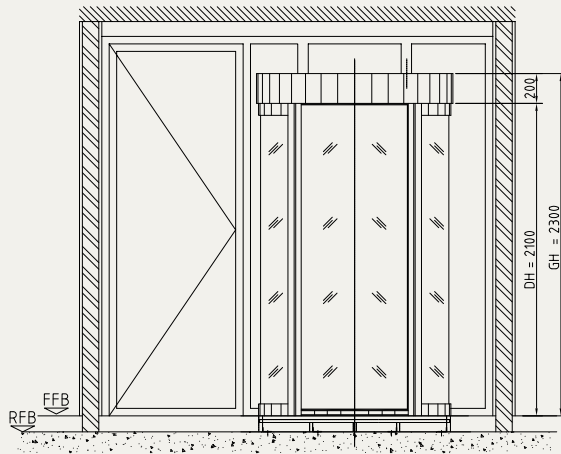

Orthos PIL-C01

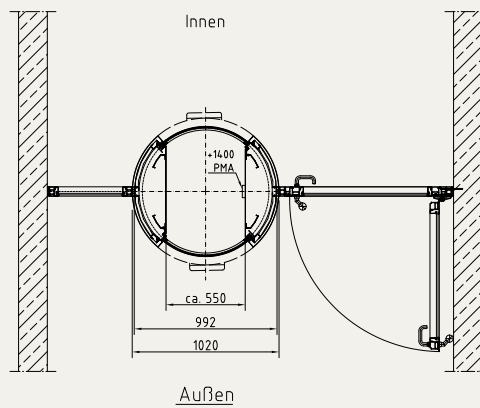
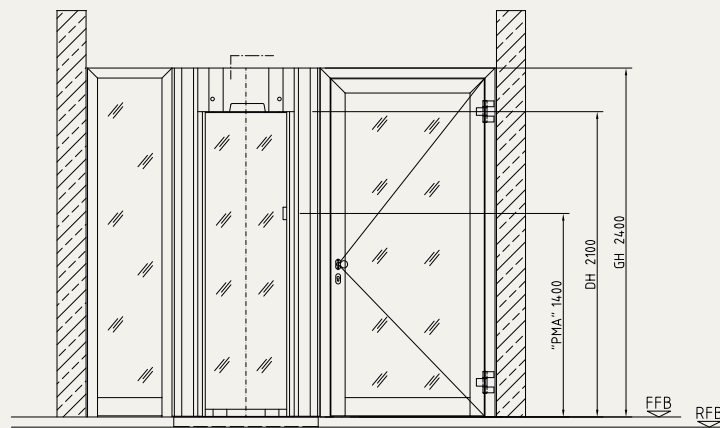

RFB	SFL
FFB	FFL
DH	PH
GH	TH
Innen	Inside
DB ca. 999	DB approx. 999
Außen	Outside



**Door
Hardware**



**Electronic
Access & Data**



**Mechanical
Key Systems**



Lodging Systems



**Entrance
Systems**



**Interior Glass
Systems**



Safe Locks



Service

dormakaba
International Holding AG
Hofwisenstrasse 24
CH-8153 Rümlang
T +41 44 818 90 11
info@dormakaba.com
www.dormakaba.com