

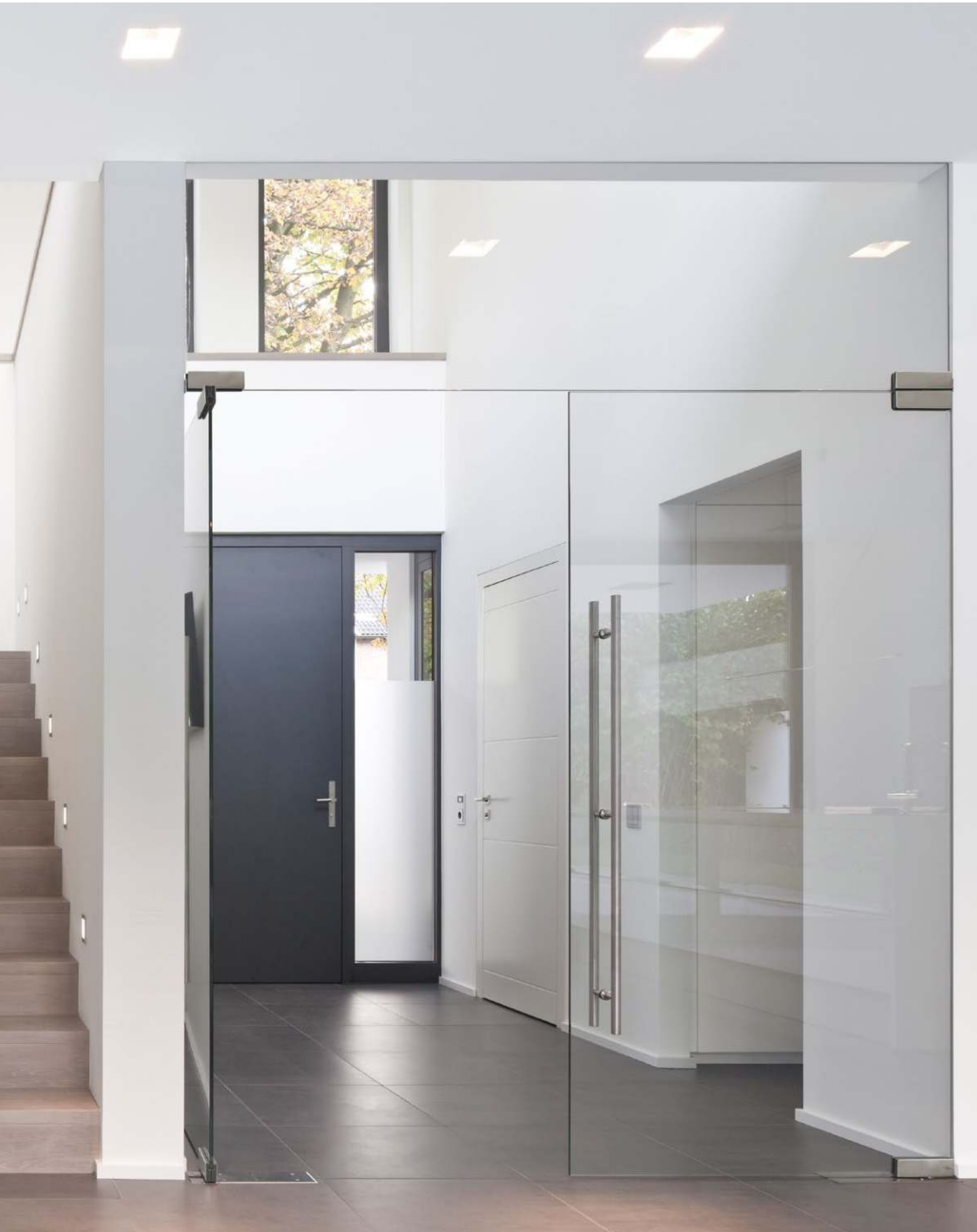

MUNDUS
UNIVERSAL
RP
BEYOND
EA
TP/TA
MANET
Compact/
Concept
SG
Wall connection
profile
MR 22/MR 28

Fittings for Toughened Glass Assemblies

Technical brochure 2021



Content



06 MUNDUS
Components for toughened glass assemblies



40 UNIVERSAL
Components for toughened glass assemblies



72 RP
Double-action door system for toughened glass assemblies



78 BEYOND
Double-action door system for toughened glass assemblies



88 EA
Components for single-action doors



102 TP/TA
Door rails for double-action and single-action doors



132 MANET Compact
Single-point fitting system, stainless steel



138 MANET Concept
Single-point fitting system, stainless steel



148 MANET Concept
Connection system



154 SG
Centre and corner locks for toughened glass assemblies



176 Wall connection profile
Bearing wall connecting profile system



182 MR 22/MR 28
Wall connecting profile system, non-bearing



188 Accessories

The dormakaba range of fittings for toughened glass assemblies

The dormakaba range of fittings for toughened glass assemblies has matured into one of the most comprehensive available today. It offers ideal options for creating all standard toughened glass assemblies in a manner which is technically sound and visually attractive. This gives the designer a wide variety of options for individual expression in creating with toughened glass – either internally or externally.

All dormakaba fittings are based on a modular system, consisting of a base unit, functional inserts and clip-on covers in the widest possible range of finishes. The glass preparations that are needed can be performed quickly and easily. Quality materials and thorough workmanship guarantee a long service life and a reflection of excellence for years to come.

Applications and features	MUNDUS Comfort/Premium		UNIVERSAL patch fittings	BEYOND	EA
For external assemblies	●	●	●		●
For internal assemblies	●	●	●	●	●
For standard toughened glass assembly types	●	●	●	●	●
For individually designed assemblies with corner fittings, fin fittings etc.			●		
For double-action doors	●	●	●	●	
For single-action doors	●	●	●	●	●
Glass thickness (mm) (Generally, glass thickness tolerances within the +/- 0.5 mm range can be accommodated)	8–12	8–22	8, 10, 12 ⁴⁾	10, 12	8, 10, 12
Glass thickness (mm), for UNIVERSAL with 15 mm pivot point			8, 10		
Max. door weight (kg)	150	200	110 ²⁾⁵⁾	80	80/110 ⁴⁾
Max. door weight (kg) for UNIVERSAL with 15 mm pivot point			80		
Max. door width (mm)	1,100	1,300	1,100 ²⁾⁵⁾	1,000/1,200 ⁴⁾	1,000/ 1,100 ⁴⁾
Max. door height (mm)	see Matrix for door dimensions, page 10		3,000 ¹⁾²⁾⁵⁾	2,200/ 3,000 ⁴⁾⁵⁾	3,000 ¹⁾²⁾
Glass type	TSG	TSG/LSG ³⁾	TSG	TSG	ESG
Double-action / single-action door	sa/da	sa/da	sa/da	sa/da	A
Materials and finishes					
Aluminum, mill finish (Aluminum R 600) (100)					
Aluminum, silver EV1 anodized (similar Eloxal I EV1 / Eloxal II C 0) (101)			●		●
Aluminum EV1-Deco anodized (compatible with finish 150)				●	
Aluminum, similar satin stainless steel anodized (113, 107)				● (107)	● (107)
Aluminum, silver anodized (Silver N 600 ST) (compatible with finish 114) (150)	●	●			
Aluminum special color anodized (199)		●	●		●
Aluminum, traffic white powder coated (300)					●
Aluminum, white powder coated (White P 100 SG) (350, RAL 9016)	●	●	●		
Aluminum, special color powder coated (399)			●		●
Brass, polished chromed (501)			●		●
Brass, polished varnished (502)					
Brass, polished (503)			●		●
Satin stainless steel (Niro S 700 ST) (700)			●		
Polished stainless steel (Niro S 700 HG) (701)			●		
Satin stainless steel (750)	●	●			
Polished stainless steel (751)	●	●			
Page	6		40	78	94

Door rails and locks ideally complement the dormakaba product range for toughened glass assemblies. The door rails grant all requests for wide and heavy doors, also for side panels. They guarantee the maximum protection for the lower glass edge.

With its different types and finishes the lock programme SG meets various requirements for function, safety and appearance.

TP/TA	MANET Compact	SG	Wall connection profile	MR 22/ MR 28
●		●	●	
●	●	●	●	●
●	●	●	●	
○				
●	●	○	○	
●	○	○		
8, 10, 10.76 12, 12.76, 13,5, 15, 17, 19, 21	10, 12	8, 10, 12	8, 10, 12, 12,7, 13,5, 15, 17, 19	6, 8, 10
150*	80		45 kg/m	
1,400*	1,200			
3,500 ¹⁾²⁾⁵⁾ 4,000 ⁴⁾	2,500 ¹⁾²⁾⁵⁾		3,000 ¹⁾²⁾⁵⁾	2,500/ 2,800 ¹⁾²⁾⁵⁾
TSG/LSG ³⁾	TSG	TSG	TSG/LSG ³⁾	TSG
sa/da	sa/da	sa/da		
●			●	
●		●	●	●
		●	●	●
●				
		●	●	
●		●		
			●	
●	●		●	
●			●	
102	132	154	176	182

- 1) For door heights up to 2,500 mm
For doors with a height of more than 2,500 mm we have to keep additional conditions/limits:
 - Glass thickness >= 10 mm
 - Usage of a handle bar with 3 connection points in minimum and a minimum height of 1/2 door height
- 2) Use of door closers:
Doors < / = 1,100 mm must be provided with door closers of type EN 3 (with or without back-check), and doors > / = 1,100 mm need to be fitted with larger door closers (e.g. EN 4, 5 or 6) with or without backcheck.
- 3) Laminated safety glass of 2 x toughened safety glass
- 4) Max. panel weight depends on product combination
- 5) Further possible glass panel heights on request at our application engineering
- 6) Under certain circumstances also 15 + 19 mm glass thicknesses

The glass dimension may differ due to items as follows:

- installation type,
- glass tolerance,
- generally use

- Optional
- Standard

*Only for double-action doors with door rail top and bottom, incl. steel door lever

Note: The use of clamp fittings on structured glass surfaces (except of which are satinized glasses) or glasses with large variations in glass thickness is only with the application of a levelling layer permissible.

Content

MUNDUS

08	General information
09	Technical information
10	Matrix MUNDUS
12	Clamp&Glue technology
14	Type illustration
16	Technical details
18	Components
29	Installation details
30	Accessories MUNDUS
34	Glass preparation
188	Accessories
212	Safety-related information



MUNDUS

MUNDUS – The freedom of versatility

Compelling benefits:

- Clear design lines, no visible fixings
- Wide range of surface finishes, colours and materials
- Particularly easy to install: Many MUNDUS fittings can be mounted on the glass and fixed into place in their as-delivered condition
- Fast installation, simple in-situ adjustment of the installed system
- set up for the right glass thickness: adaptable to different glass thicknesses without the need to change gaskets
- Improved load-bearing performance and more secure hold thanks to high-strength materials (screws and threaded sleeves of high-grade stainless steel capable of absorbing high clamping forces)
- Use of laminated safety glass (LSG) using dormakaba's proven Clamp&Glue technology for high quality and safety demands (MUNDUS Premium)

Elegant appearance

MUNDUS fittings impress through their elegant design combining sharply defined, straight edges and rounded corners, high-quality materials and careful workmanship. There are no fixings to disrupt the smooth harmony of the surface finish. For a durable, elegant appearance, the cap consists of 2 mm thick and therefore particularly robust material – stainless steel or aluminum.

MUNDUS offers patch fittings for 24 standard systems and numerous special solutions

– whether for an open-plan residential ambience, attractive office or prestigious shop entrance. Visually and technically impressive, MUNDUS glass fittings are suitable for a wide range of different requirements. The extensive portfolio encompasses connection fittings for the usual 24 standard systems such as PT 10, PT 40 or PT 70. It also accommodates special solutions for custom spatial requirements, such as PT 41 and PT 61 for glass assemblies stiffened with 90° glass fins.

Quick and easy to install

MUNDUS fittings offer multi-dimensional in-situ adjustability, ensuring a firm fit every time. They facilitate infinite variability of the vertical gap dimensions and thus consistently correct setting of the pivot axis and zero position.

Wide choice of finishes

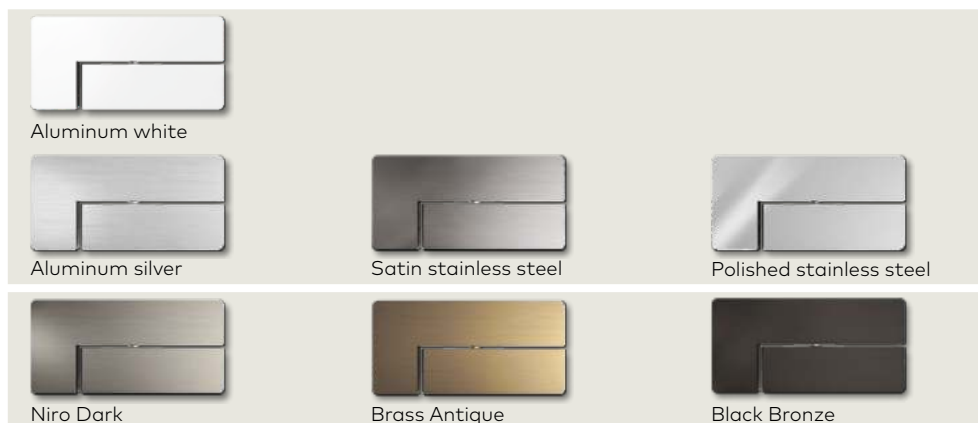

Standard collection
dormakaba standard finishes, anodized or coated, satin or polished stainless steel.

Exclusive collection
Treated metals such as anodized aluminum.

MUNDUS – the technical specifications at a glance

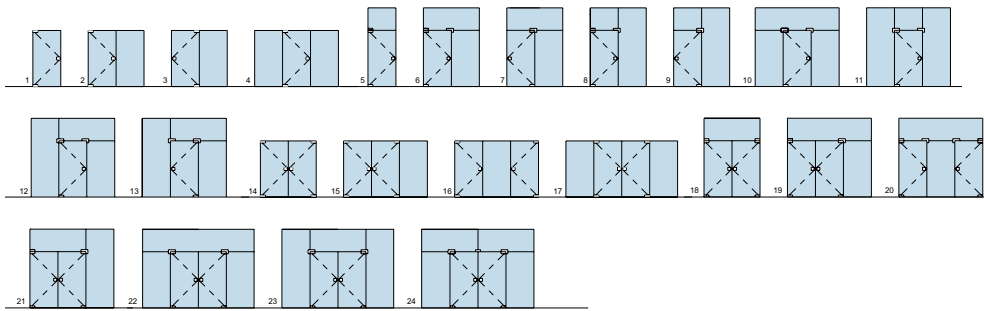

MUNDUS	MUNDUS Premium	MUNDUS Comfort
Max. load-bearing capacity	200 kg	150 kg
Max. panel width	1,300 mm	1,100 mm
	The max. panel width depends on glass thickness and weight. For more information please see on the following page MUNDUS - Matrix for door dimensions.	
Possible glass thickness	8–12 mm 12–15 mm 15–19 mm 19–22 mm	8–12 mm
Suitable for LSG*	●	–
Supported pivot points in mm	55, 65, 70 mm	55, 65, 70 mm
Offset adjustability in mm	Infinite (± 3 mm); 52–73 mm	Infinite (± 3 mm); 52–73 mm
Adjustability of the door/insert	Multi-dimensional	Multi-dimensional
Cover materials	Stainless steel, aluminum, glass etc.	Stainless steel, aluminum
Test cycles:	1,000,000	500,000
Inhouse-Test according to EN 12400	Test certificates from an external accredited authority can be provided on request.	
Inhouse-Test according to EN 1670		

Materials and finishes	Availability	Corrosion class	Availability	Corrosion class
Standard collection				
Aluminum, white powder coated (White P 100 SG) (350, RAL 9016)	●	4	●	4
Aluminum, silver anodized (Silver N 600 ST) (compatible with finish 114) (150)	●	4	●	4
Satin stainless steel (Niro S 700 ST) (for MUNDUS) (750)	●	4	●	4
Polished stainless steel (Niro S 700 HG) (for MUNDUS) (751)	●	4	●	4
Special colour at option, powder coated (399)	●	4	●	4
Exclusiv collection (Special colour anodized, 199)				
Niro Dark (157)	●	4	–	
Brass Antique	●	4	–	
Black Bronze	●	4	–	

1 – 4 Corrosion class according to EN 1670 (independent test confirmation on request) • Standard – not available

* LSG out of 2 x TSG (= 2 panes each with a minimum glass thickness of 5 mm). Can be implemented with separately ordered gaskets and deploying dormakaba's proven Clamp&Glue technology.

MUNDUS – Matrix for door dimensions

This matrix is only used to select the correct fitting and does not represent a static!

height (mm)	8 mm glass width (mm)				10–12 mm glass width (mm)				12–15 mm glass width (mm)				15–19 mm glass width (mm)				19–22 mm glass width (mm)			
	1,000	1,100	1,200	1,300	1,000	1,100	1,200	1,300	1,000	1,100	1,200	1,300	1,000	1,100	1,200	1,300	1,000	1,100	1,200	1,300
2,000	Green	Green	Green	Green	Green	Green	Green	Green	Green	Green	Green	Green	Green	Green	Green	Green	Yellow	Yellow	Yellow	Yellow
2,100	Blue	Blue	Blue	Blue	Green	Green	Green	Green	Green	Green	Green	Green	Green	Green	Green	Green	Yellow	Yellow	Yellow	Yellow
2,200	Blue	Blue	Blue	Blue	Green	Green	Green	Green	Green	Green	Green	Green	Green	Green	Green	Green	Yellow	Yellow	Yellow	Yellow
2,300	Blue	Blue	Blue	Blue	Green	Green	Green	Green	Green	Green	Green	Green	Green	Green	Green	Green	Yellow	Yellow	Yellow	Yellow
2,400	Blue	Blue	Blue	Blue	Green	Green	Green	Green	Green	Green	Green	Green	Green	Green	Green	Green	Yellow	Yellow	Yellow	Yellow
2,500	Blue	Blue	Blue	Blue	Green	Green	Green	Green	Green	Green	Green	Green	Green	Green	Green	Green	Yellow	Yellow	Yellow	Yellow
2,600	Orange	Orange	Orange	Orange	Blue	Blue	Blue	Blue	Green	Green	Green	Green	Green	Green	Green	Green	Yellow	Yellow	Yellow	Yellow
2,700	Orange	Orange	Orange	Orange	Blue	Blue	Blue	Blue	Green	Green	Green	Green	Green	Green	Green	Green	Yellow	Yellow	Yellow	Red
2,800	Orange	Orange	Orange	Orange	Blue	Blue	Blue	Blue	Green	Green	Green	Green	Green	Green	Green	Green	Yellow	Yellow	Yellow	Red
2,900	Orange	Orange	Orange	Orange	Blue	Blue	Blue	Blue	Green	Green	Green	Green	Green	Green	Green	Green	Yellow	Yellow	Yellow	Red
3,000	Orange	Orange	Orange	Orange	Blue	Blue	Blue	Blue	Green	Green	Green	Green	Green	Green	Green	Green	Yellow	Yellow	Yellow	Red
3,100	Orange	Orange	Orange	Orange	Orange	Orange	Orange	Orange	Yellow	Yellow	Yellow	Yellow	Yellow	Yellow	Yellow	Yellow	Yellow	Yellow	Yellow	Red
3,200	Orange	Orange	Orange	Orange	Orange	Orange	Orange	Orange	Yellow	Yellow	Yellow	Yellow	Yellow	Yellow	Yellow	Yellow	Yellow	Yellow	Yellow	Red
3,300	Orange	Orange	Orange	Orange	Orange	Orange	Orange	Orange	Yellow	Yellow	Yellow	Yellow	Yellow	Yellow	Yellow	Yellow	Yellow	Yellow	Yellow	Red
3,400	Orange	Orange	Orange	Orange	Orange	Orange	Orange	Orange	Yellow	Yellow	Yellow	Yellow	Yellow	Yellow	Yellow	Yellow	Yellow	Yellow	Yellow	Red
3,500	Orange	Orange	Orange	Orange	Orange	Orange	Orange	Orange	Yellow	Yellow	Yellow	Yellow	Yellow	Yellow	Yellow	Yellow	Yellow	Yellow	Yellow	Red
3,600	Orange	Orange	Orange	Orange	Orange	Orange	Orange	Orange	Orange	Orange	Orange	Orange	Orange	Orange	Orange	Orange	Orange	Orange	Orange	Red
3,700	Orange	Orange	Orange	Orange	Orange	Orange	Orange	Orange	Orange	Orange	Orange	Orange	Orange	Orange	Orange	Orange	Orange	Orange	Orange	Red
3,800	Orange	Orange	Orange	Orange	Orange	Orange	Orange	Orange	Orange	Orange	Orange	Orange	Orange	Orange	Orange	Orange	Orange	Orange	Orange	Red
3,900	Orange	Orange	Orange	Orange	Orange	Orange	Orange	Orange	Orange	Orange	Orange	Orange	Orange	Orange	Orange	Orange	Orange	Orange	Orange	Red
4,000	Orange	Orange	Orange	Orange	Orange	Orange	Orange	Orange	Orange	Orange	Orange	Orange	Orange	Orange	Orange	Orange	Orange	Orange	Orange	Red

- Suitable for use without any technical limitations.
- Pull handle necessary extending over 1/2 of the door height with at least 3 fixing points.
- Glass and fitting must be adhesive-bonded.
- Use of MUNDUS fittings is not recommended. Please contact your dormakaba partner in order to discuss possible alternatives.
- This door dimension is unfortunately not possible with MUNDUS.

Extensive suitability, effortless installation





MUNDUS Premium – Providing a totally reliable hold – Clamp&Glue technology

Providing a totally reliable hold – Clamp&Glue technology

Proven dormakaba technology for the installation of laminated safety glass. An additional adhesive bond ensures a firm hold and permanent cohesion between fitting and glass.

The bonding process following the fixing of the fitting is remarkably easy:

- Before commencing with the gluing operation, you will need to replace the standard gaskets with special gaskets suitable for laminated safety glass*
- The glue is fed through the holes provided until it emerges from the overflow openings in the clamp fittings
- The process is then repeated on the rear face
- Allow the glue to harden.

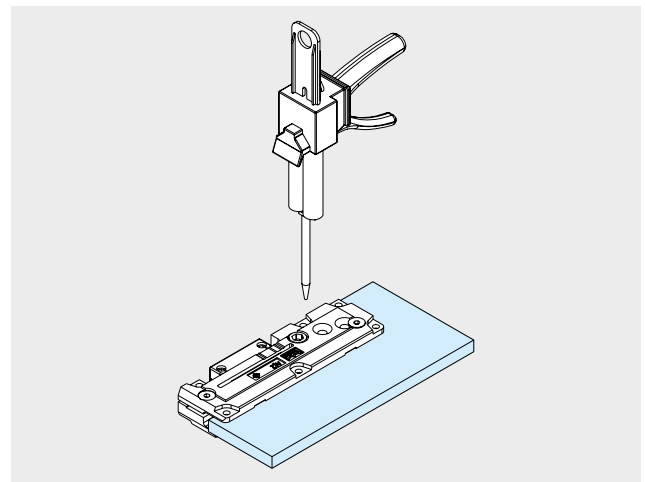

*The LSG gaskets may only be used when fixing glass using the Clamp&Glue technology

MUNDUS and laminated safety glass (LSG) – a combination that offers impressive advantages:

- High safety for users, even in the case of large glass assemblies
- Improved acoustic insulation and reduced noise levels achievable by integrating a sound deadening film
- Deploying glass doors as a design element – specially designed films for individual aesthetics
- Use of LSG comprising 2 x TSG (= 2 panes each with a minimum glass thickness of 5 mm).

Type illustration

Toughened glass assemblies with fittings (55/65/70 mm pivot point) and locks.

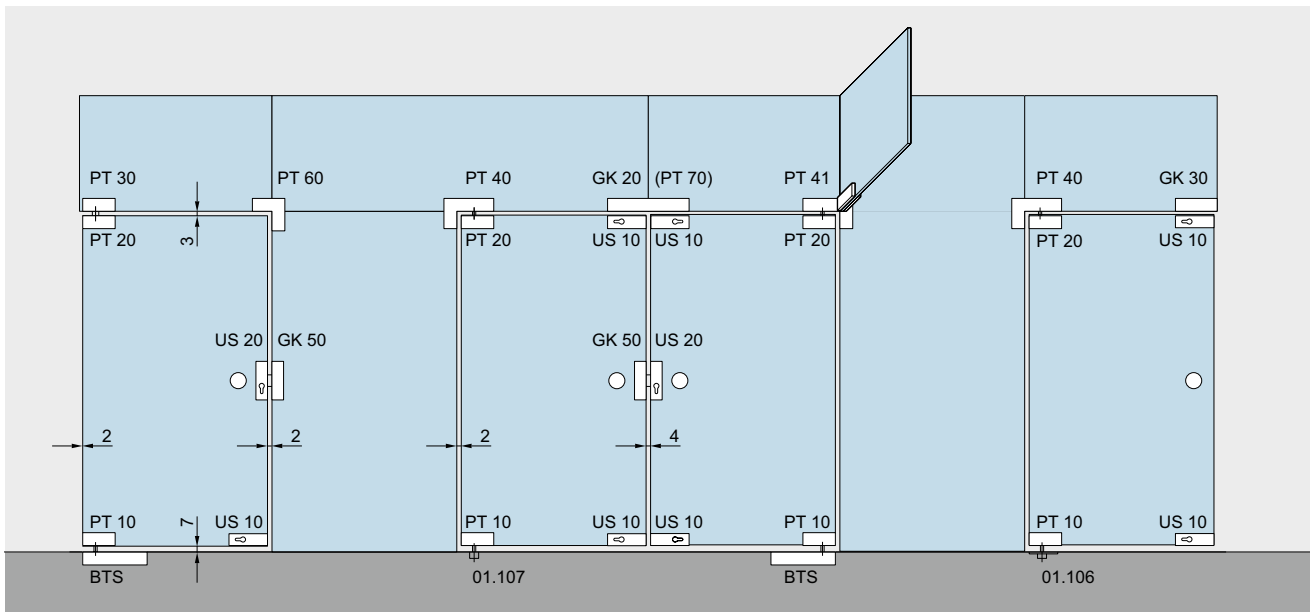
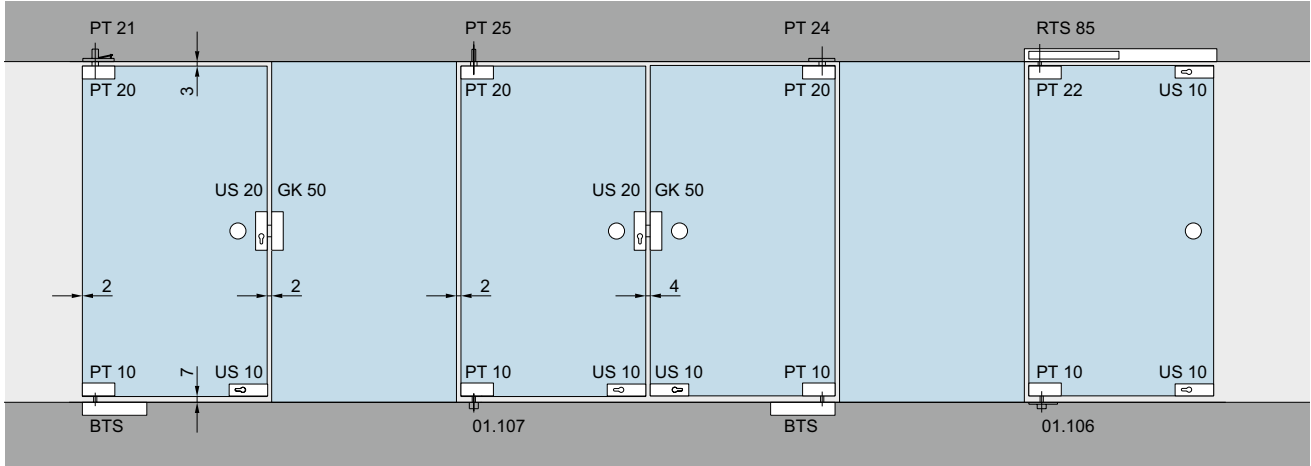

BTS = Floor spring
GK = Strike box

PT = Patch
RTS = Transom closer

US = Lock

Maximum door weight and width for MUNDUS fittings

Max. door weight:
MUNDUS Premium: 200 kg
MUNDUS Comfort: 150 kg

Max. door width:
MUNDUS Premium: 1,300 mm
MUNDUS Comfort: 1,100 mm

For doors with a height of more than 2,500 mm we should keep additional conditions/limits:

- Glass thickness ≥ 10 mm
- Usage of a handle bar with 3 connection points in minimum and a minimum height of 1/2 door height

The max. panel width depends on glass thickness and weight. For more information please see on page 10, MUNDUS - Matrix for door dimensions.

Use of door closers:

Doors $\leq 1,100$ mm must be provided with door closers of type EN 3 (with or without backcheck), and doors $> 1,100$ mm need to be fitted with larger door closers (e.g. EN 4, 5 or 6) with or without backcheck.

Glass panels

The individual glass panels may show production tolerances in geometry and dimensions that sum up to larger deviations in larger glass assemblies. These deviations are not shown in the exemplary constructional set up above.

Note for stiffening elements:

"Left" or "Right" is always determined from the outside and as viewed from above.

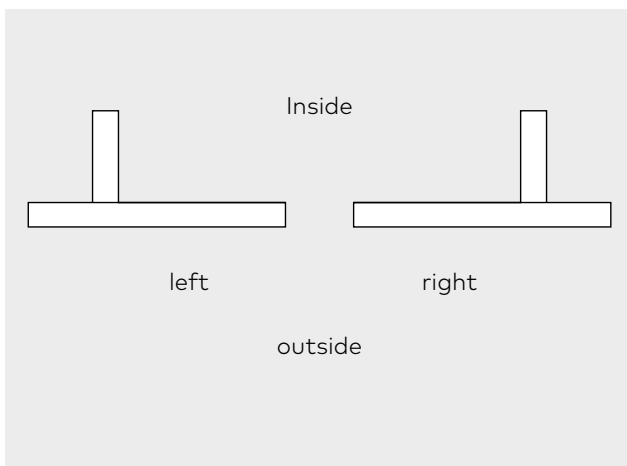

Easy to install, easy to adjust

Fast and uncomplicated fixing

MUNDUS patch fittings always fit snugly on the glass thanks to their multi-dimensional variability. They facilitate infinite adjustment of the vertical gap dimensions and location accuracy in terms of both pivot point and zero position.

Optimum gap dimensions

Thanks to the infinitely variable, multi-dimensional adjustability of the patch fittings, the door can be optimally aligned following installation.

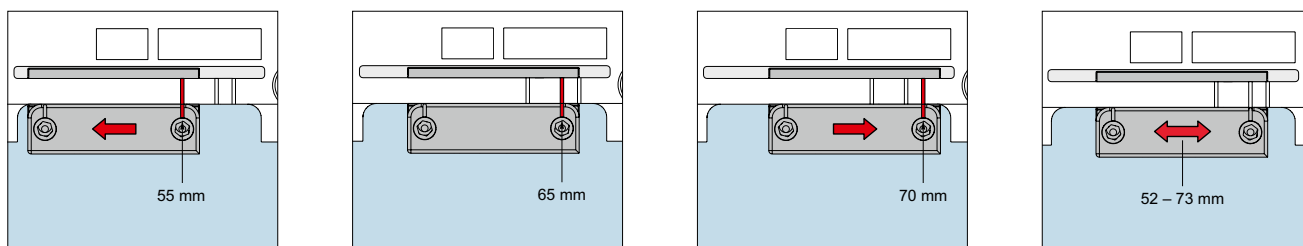

Multi-dimensional adjustability even when mounted

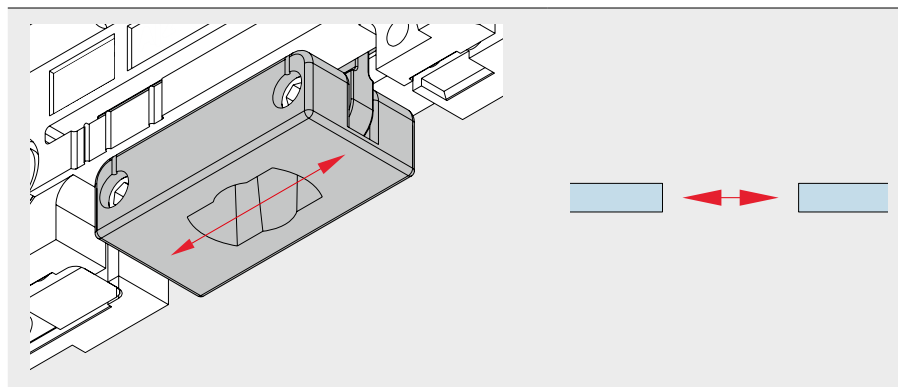

Alignment in the X axis

Individual adjustment of the pivot point, infinitely variable between 52 and 73 mm.

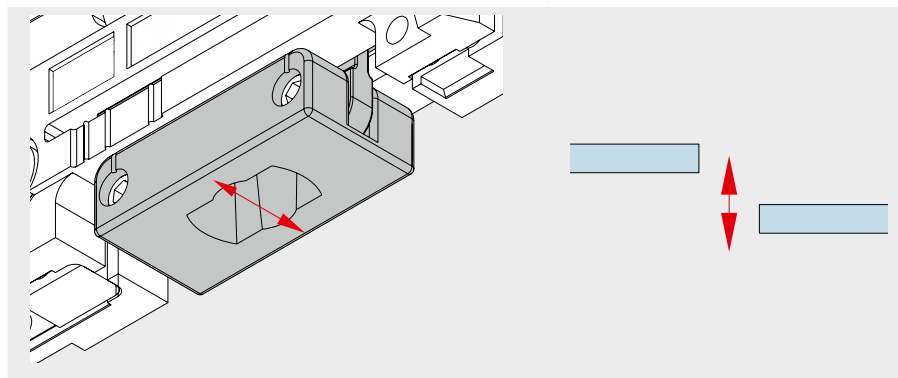

Alignment in the Z axis

Infinite variability of the door position to achieve flush alignment thanks to adjustment of up to 1 mm for a glass thickness of 8 mm, or 3 mm for a glass thickness of 12 mm.

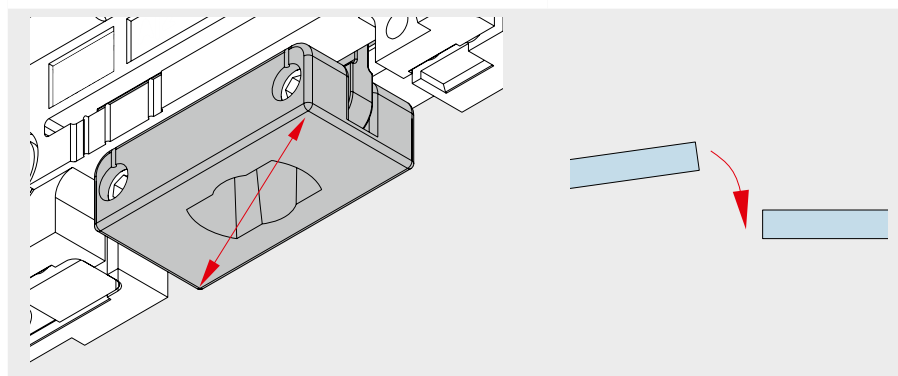

Zero position adjustment

Infinite alignment variability of the door to achieve the correct zero position by adjustment around the axis of rotation in the range +/- 1.5°.

Easy to install, safe and secure

With MUNDUS, you do not require new or additional gaskets in order to adjust the fittings to the glass thickness. With MUNDUS, the glass thickness is defined by two screws in the base unit of the patch fitting, allowing the use of glazing ranging from 8 to 22 mm.



Suitable for different glass thicknesses

MUNDUS Premium:
Accommodating glass thicknesses of 8–12 mm, 12–15 mm, 15–19 mm and 19–22 mm with infinite adjustability in a single fitting. The gaskets that you had to separately order for toughened safety glass are now a thing of the past. You always have the right fitting to hand. That means: fast installation, more time, more design content.

Glass thickness:	8–12 mm
	12–15 mm
	15–19 mm
	19–22 mm
Max. Door weights:	200 kg

MUNDUS Comfort:	
Glass thickness:	8–12 mm
Max. Door weights:	150 kg

Protection from unauthorised access

The positioning of the clamping screws also provides for additional protection against unauthorised access to your interiors. The screws are distributed on both sides of the base unit so that disassembly from one side is not possible.

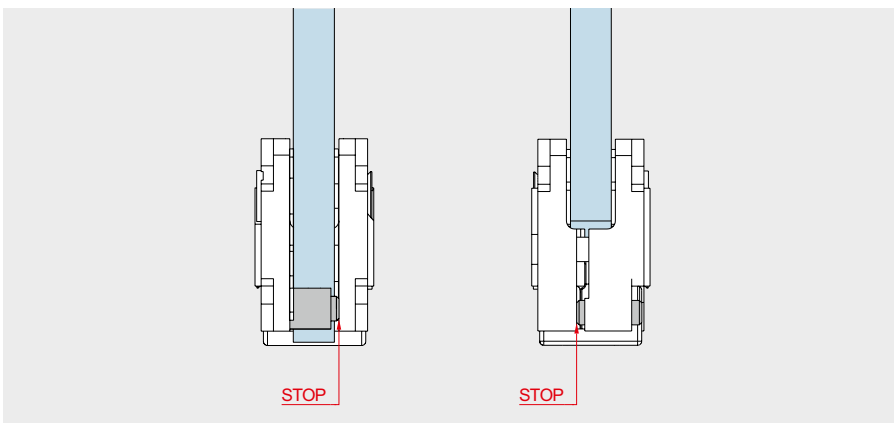

Patch fittings

Shown with 10 mm glass. When used with other glass thicknesses, the measurements change accordingly.

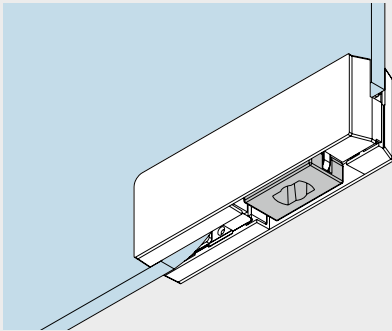
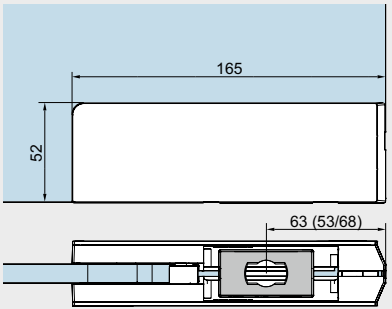
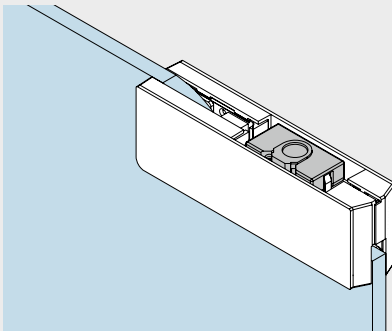
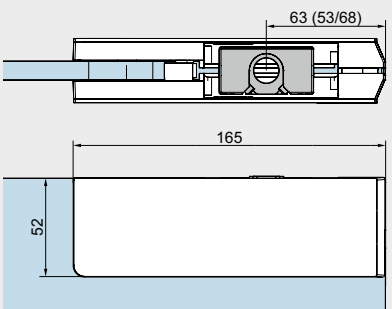
	Product description	Glass thickness	Art. No.
	<p>PT 10 Premium bottom patch fitting use for flat-conical floor spring spindle or round pivot Ø 14 mm. For glass weight up to 200 kg and use with toughened safety glass (TSG). Also prepared for use with laminated safety glass (LSG) – separate gaskets required</p>	8–12 mm	42.100
		12–15 mm	42.101
		15–19 mm	42.102
		19–22 mm	42.103
	<p>PT 10 Comfort bottom patch fitting use for flat-conical floor spring spindle or round pivot Ø 14 mm. For glass weight up to 150 kg and use with toughened safety glass (TSG).</p>	8–12 mm	38.100
	<p>PT 20 Premium top patch fitting with plastic socket for pivot Ø 14 mm. For glass weight up to 200 kg and use with toughened safety glass (TSG). Also prepared for use with laminated safety glass (LSG) – separate gaskets required.</p>	8–12 mm	42.200
		12–15 mm	42.201
		15–19 mm	42.202
		19–22 mm	42.203
	<p>PT 20 Comfort top patch fitting with plastic socket for pivot Ø 14 mm. For glass weight up to 150 kg and use with toughened safety glass (TSG).</p>	8–12 mm	38.200

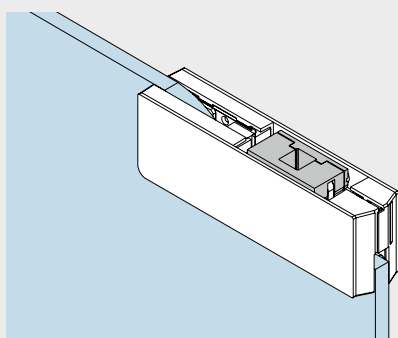
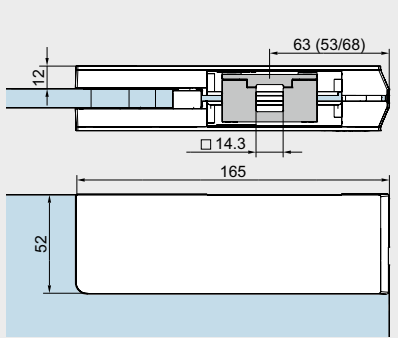
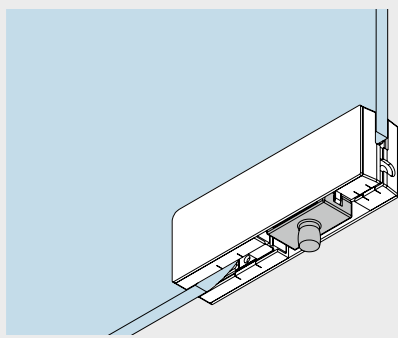
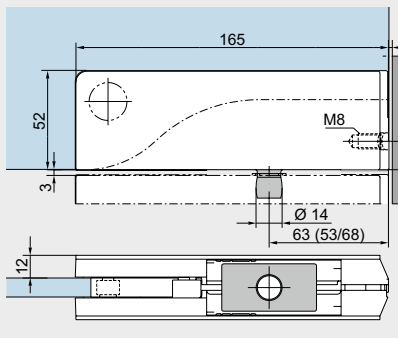
	Product description	Glass thickness	Art. No.
	<p>PT 22 Premium* top patch fitting for a glass weight up to 80 kg with insert for transom closer RTS. For use with toughened safety glass (TSG). Also prepared for use with laminated safety glass (LSG) – separate gaskets required.</p>	<p>8–12 mm 12–15 mm 15–19 mm 19–22 mm</p>	<p>42.220 42.221 42.222 42.223</p>
	<p>PT 22 Comfort* top patch fitting with insert for transom closer RTS. For use with toughened safety glass (TSG).</p>	<p>8–12 mm</p>	<p>38.220</p>
	<p>PT 30 Premium overpanel patch fitting with pivot Ø 14 mm and M 8 tapped hole at side. For use with toughened safety glass (TSG). Also prepared for use with laminated safety glass (LSG) – separate gaskets required.</p>	<p>8–12 mm 12–15 mm 15–19 mm 19–22 mm</p>	<p>42.300 42.301 42.302 42.310</p>
	<p>PT 30 Comfort overpanel patch fitting with pivot Ø 14 mm and M 8 tapped hole at side. for use with toughened safety glass (TSG).</p>	<p>8–12 mm</p>	<p>38.300</p>

* The maximum permissible door heights and door widths depend on the closing device used and its spring strength / closing force. The maximum allowable door weight in combination with an RTS transom-concealed door closer is 110 kg, the maximum allowable panel width is 1,100 mm.

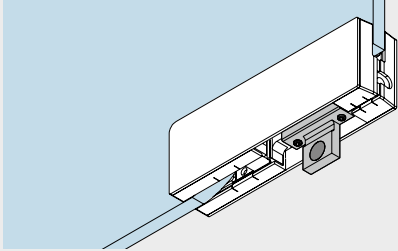
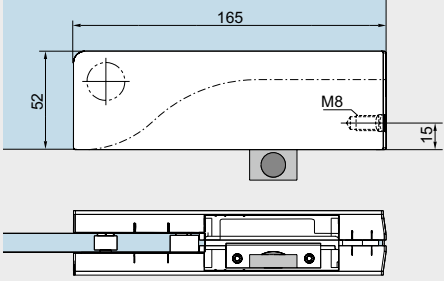
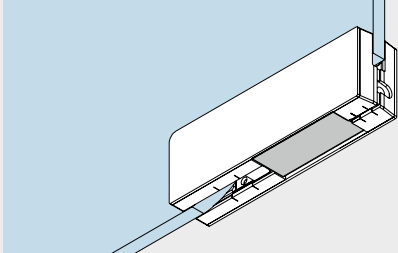
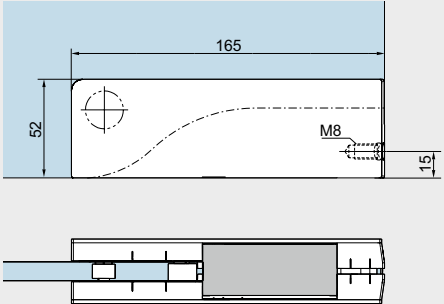
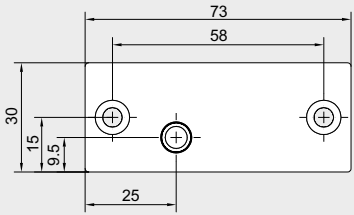
	Product description	Glass thickness	Art. No.
	<p>PT 30 Premium overpanel patch fitting with stop insert. For use with toughened safety glass (TSG). Also prepared for use with laminated safety glass (LSG) – separate gaskets required.</p>	<p>8–15 mm 15–19 mm 19–22 mm</p>	<p>42.303 42.305 42.311</p>
	<p>PT 30 Comfort overpanel patch with stop insert. For use with toughened safety glass (TSG).</p>	<p>8–15 mm</p>	<p>38.303</p>
	<p>PT 30 Premium overpanel patch fitting with blanking insert. For use with toughened safety glass (TSG). Also prepared for use with laminated safety glass (LSG) – separate gaskets required.</p>	<p>8–15 mm 15–19 mm 19–22 mm</p>	<p>42.306 42.308 42.312</p>
	<p>PT 30 Comfort overpanel patch with blanking insert. For use with toughened safety glass (TSG).</p>	<p>8–15 mm</p>	<p>38.306</p>
	<p>Fixing plate for MUNDUS overpanel patch fitting PT 30 and MUNDUS overpanel strike box GK 30 Weight in kg: 0.039</p> <p>Only available in satinized stainless steel, polished stainless steel or powder-coated stainless steel. Optionally wall anchor and threaded rod are applicable. (see page 31.)</p>	<p>38.313</p>	

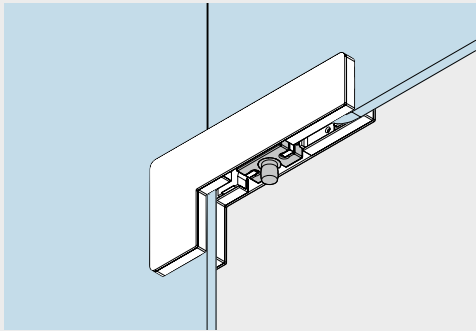
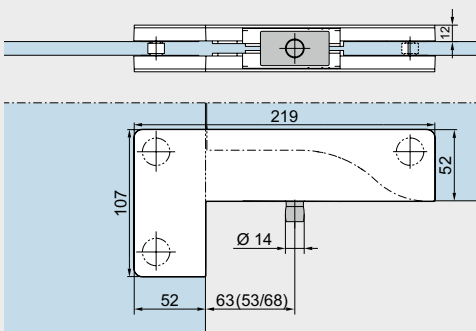
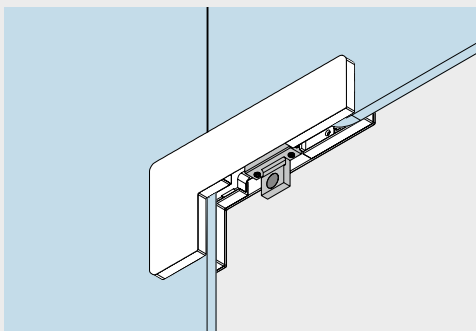
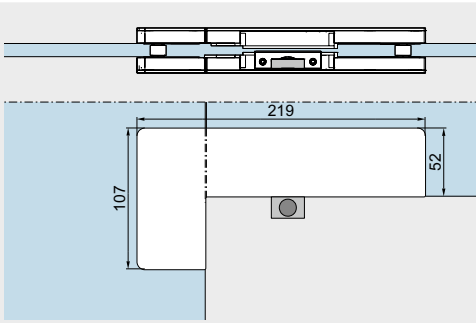
	Product description	Glass thickness	Art. No.
	<p>PT 40 Premium patch for overpanel and sidelight with pivot Ø 14 mm. For use with toughened safety glass (TSG). Also prepared for use with laminated safety glass (LSG) – separate gaskets required.</p> <p>Please note: The load-bearing capability of the overpanel (fan light) is only ensured when using suitable wall connection profiles.</p>	<p>8–12 mm 12–15 mm 15–19 mm 19–22 mm</p>	<p>42.400 42.401 42.402 42.470</p>
	<p>PT 40 Comfort patch for overpanel and sidelight with pivot Ø 14 mm. For use with toughened safety glass (TSG).</p> <p>Please note: The load-bearing capability of the overpanel (fan light) is only ensured when using suitable wall connection profiles.</p>	<p>8–12 mm</p>	<p>38.400</p>
	<p>PT 40 Premium patch for overpanel and sidelight with stop insert. For use with toughened safety glass (TSG). Also prepared for use with laminated safety glass (LSG) – separate gaskets required.</p> <p>Please note: The load-bearing capability of the overpanel (fan light) is only ensured when using suitable wall connection profiles.</p>	<p>8–15 mm 15–19 mm 19–22 mm</p>	<p>42.403 42.405 42.471</p>
	<p>PT 40 Comfort patch for overpanel and sidelight with stop insert. For use with toughened safety glass (TSG).</p> <p>Please note: The load-bearing capability of the overpanel (fan light) is only ensured when using suitable wall connection profiles.</p>	<p>8–15 mm</p>	<p>38.403</p>

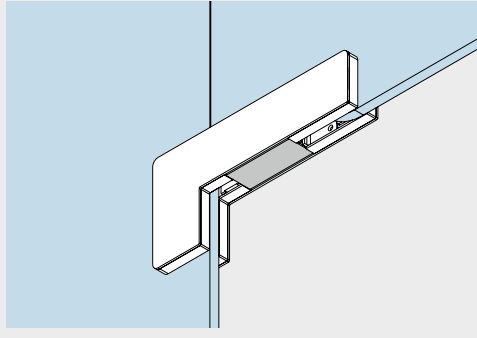
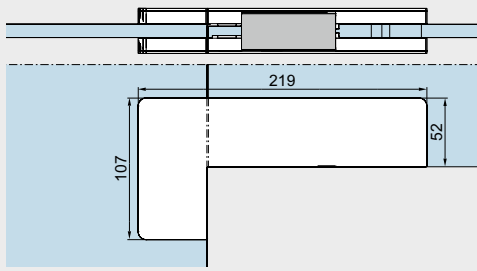
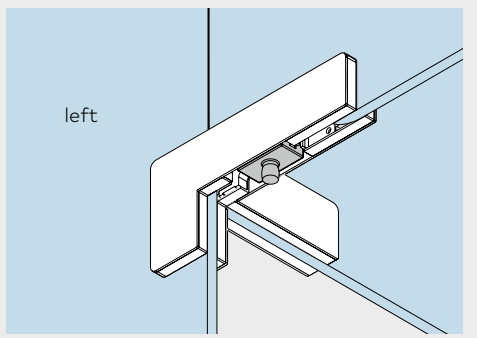
	Product description	Glass thickness	Art. No.	
	<p>PT 40 Premium patch for overpanel and sidelight with blanking insert. For use with toughened safety glass (TSG). Also prepared for use with laminated safety glass (LSG) – separate gaskets required.</p> <p>Please note: The load-bearing capability of the overpanel (fan light) is only ensured when using suitable wall connection profiles.</p>	<p>8–15 mm 42.406 15–19 mm 42.408 19–22 mm 42.409</p>		
		<p>PT 40 Comfort patch for overpanel and sidelight with blanking insert. For use with toughened safety glass (TSG).</p> <p>Please note: The load-bearing capability of the overpanel (fan light) is only ensured when using suitable wall connection profiles.</p>	<p>8–15 mm 38.406</p>	
			<p>PT 41 Premium patch for overpanel and sidelight with pivot pin Ø 14 mm and fin fitting*. For use with toughened safety glass (TSG). Also prepared for use with laminated safety glass (LSG) – separate gaskets required.</p>	<p>left 8–12 mm 42.410 12–15 mm 42.411 15–19 mm 42.412 19–22 mm 42.472</p>
<p>right 8–12 mm 42.420 12–15 mm 42.421 15–19 mm 42.422 19–22 mm 42.474</p>				
<p>with stop insert left 8–15 mm 42.413 15–19 mm 42.415 19–22 mm 42.473</p>				
<p>right 8–15 mm 42.423 15–19 mm 42.425 19–22 mm 42.475</p>				
<p>with blanking insert left 8–15 mm 42.416 15–19 mm 42.418 19–22 mm 42.419</p>				
<p>right 8–15 mm 42.426 15–19 mm 42.428 19–22 mm 42.429</p>				

Please note:
The load-bearing capability of the overpanel (fan light) is only ensured when using suitable wall connection profiles.

* Left hand fin (illustration shows left hand) / right hand fin. Left or right hand are determined by view from outside.

Product description	Glass thickness	Art. No.	
PT 41 Comfort patch for overpanel and sidelight with pivot pin Ø 14 mm and fin fitting*. For use with toughened safety glass (TSG).	with pivot pin	left 8-12 mm right 8-12 mm	38.410 38.420
	with stop insert	left 8-15 mm right 8-15 mm	38.413 38.423
	with blanking insert	left 8-15 mm right 8-15 mm	38.416 38.426

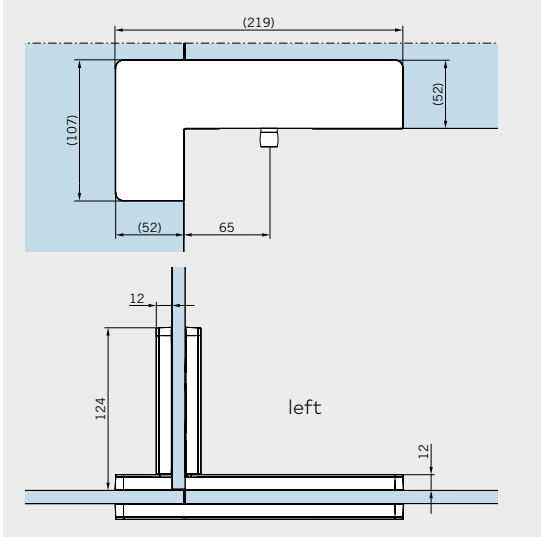

Please note:

The load-bearing capability of the overpanel (fan light) is only ensured when using suitable wall connection profiles.

* Left hand fin (illustration shows left hand) / right hand fin. Left or right hand are determined by view from outside.

Connector patches

Shown with 10 mm glass. When used with other glass thicknesses, the measurements change accordingly.

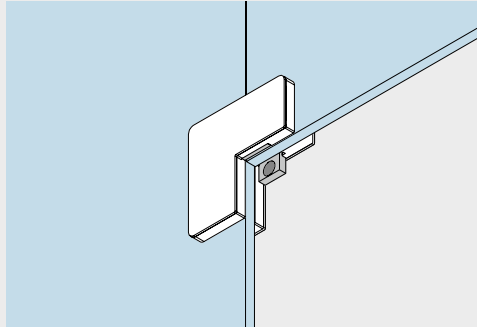
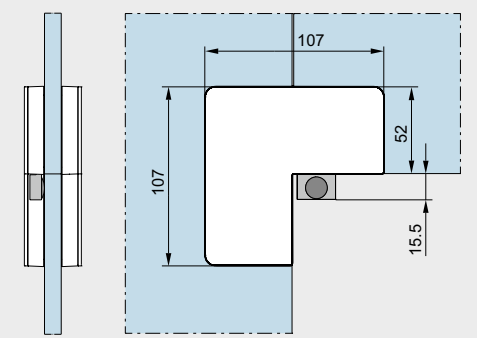
	Product description	Glass thickness	Art. No.
	<p>PT 60 Premium connector for double and single-action doors with 1 stop insert and 2 blanking inserts. For use with toughened safety glass (TSG). Also prepared for use with laminated safety glass (LSG) – separate gaskets required.</p> <p>Please note: The load-bearing capability of the overpanel (fan light) is only ensured when using suitable wall connection profiles.</p>	8–15 mm 15–19 mm 19–22 mm	42.600 42.602 42.603
	<p>PT 60 Comfort connector for double and single-action doors with 1 stop insert and 2 blanking inserts. For use with toughened safety glass (TSG).</p> <p>Please note: The load-bearing capability of the overpanel (fan light) is only ensured when using suitable wall connection profiles.</p>	8–15 mm	38.600

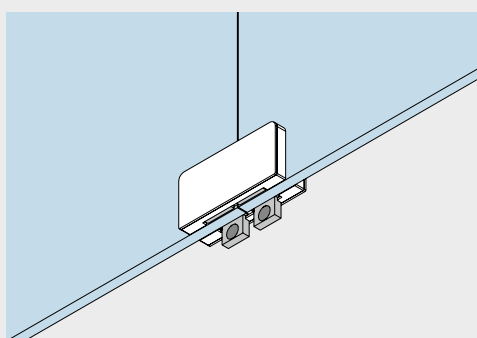
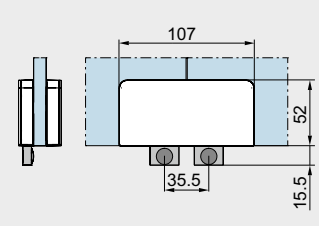
	Product description	Glass thickness	Art. No.
	<p>PT 70 Premium overpanel connector with 2 stop inserts and 2 blanking inserts. For use with toughened safety glass (TSG). Also prepared for use with laminated safety glass (LSG) – separate gaskets required.</p>	<p>8–15 mm 15–19 mm 19–22 mm</p>	<p>42.700 42.702 42.703</p>
	<p>PT 70 Comfort overpanel connector with 2 stop inserts and 2 blanking inserts. For use with toughened safety glass (TSG).</p>	<p>8–15 mm</p>	<p>38.700</p>

Locks and strike boxes

Shown with 10 mm glass. When used with other glass thicknesses, the measurements change accordingly.

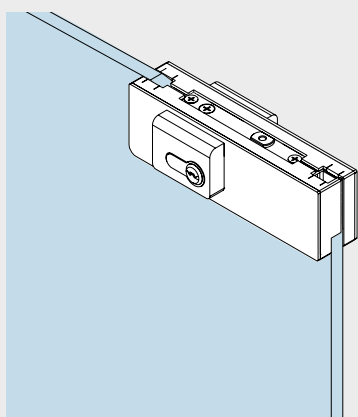
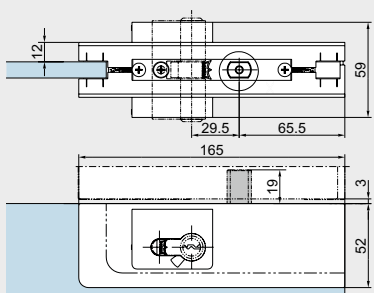
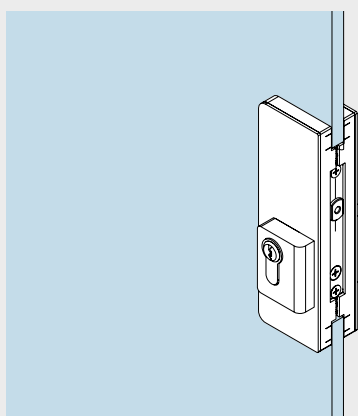
	Product description	Glass thickness	Art. No.
	<p>US 10 Premium corner lock prepared for Euro profile cylinder, single throw, bolt projection 20 mm, with security rosettes on both sides 14 mm thick, for use with toughened safety glass (TSG). Also prepared for use with laminated safety glass (LSG) – separate gaskets required. With the order please indicate the exact glass thickness! Lock insert:</p> <ul style="list-style-type: none"> • maximum corrosion resistance according to EN 1670, class 4 • with regard to type test according to DIN 18251 / (EN 12209) class 3* 	8–19 mm 19–22 mm	42.510 42.517
	<p>US 10 Comfort corner lock for use with toughened safety glass (TSG) KABA, for use with toughened safety glass (TSG) With the order please indicate the exact glass thickness!</p>	8–19 mm	38.513
	<p>US 20 Premium center lock prepared for Euro profile cylinder, single throw, bolt projection 20 mm, with security rosettes 14 mm thick, for use with toughened safety glass (TSG). Also prepared for use with laminated safety glass (LSG) – separate gaskets required. With the order please indicate the exact glass thickness! Lock insert:</p> <ul style="list-style-type: none"> • maximum corrosion resistance according to EN 1670, class 4 • with regard to type test according to DIN 18251 / (EN 12209) class 3* 	8–19 mm 19–22 mm	42.520 42.518
	<p>prepared for KABA (Swiss profile round cylinder 22 mm) for use with toughened safety glass (TSG). Also prepared for use with laminated safety glass (LSG) – separate gaskets required. With the order please indicate the exact glass thickness!</p>	8–19 mm 19–22 mm	42.523 42.519

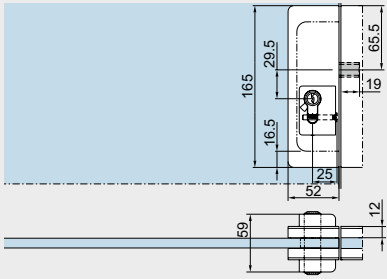
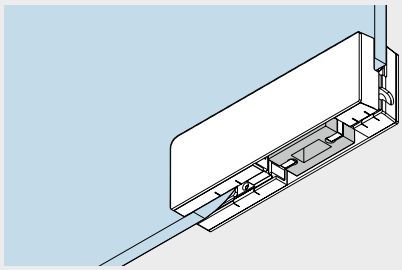
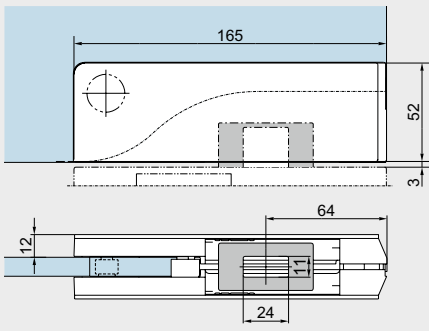
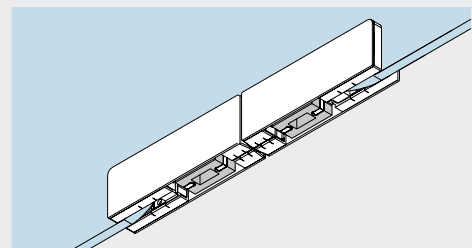
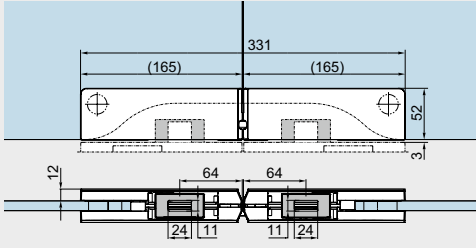
	Product description	Glass thickness	Art. No.
	<p>US 20 Comfort center lock for use with toughened safety glass (TSG)</p> <p>KABA, for use with toughened safety glass (TSG) With the order please indicate the exact glass thickness!</p> <p>* Extract from DIN 18251, class 3: Type-test with 50,000 locking bolt operating cycles. Furthermore the lock was tested successfully by a neutral testing institute with 100,000 locking bolt operating cycles.</p>	8–19 mm	38.520
	<p>GK 30 Premium single overpanel strike box with tapped hole at side. Suitable for corner lock US 10. For use with toughened safety glass (TSG). Also prepared for use with laminated safety glass (LSG) – separate gaskets required.</p> <p>To install correctly, you will need to use either a screw-on fixing bracket, a wall anchor or a threaded rod fixing, see page 31.</p>	8–15 mm 15–19 mm 19–22 mm	42.530 42.532 42.548
	<p>GK 30 Comfort single overpanel strike box with tapped hole at side. Suitable for corner lock US 10. For use with toughened safety glass (TSG).</p> <p>To install correctly, you will need to use either a screw-on fixing bracket, a wall anchor or a threaded rod fixing, see page 31.</p>	8–12 mm	38.530
	<p>GK 20 Premium double overpanel strike box Suitable for corner lock US 10 consisting of two GK 30 with threaded connecting bolt. For use with toughened safety glass (TSG). Also prepared for use with laminated safety glass (LSG) – separate gaskets required.</p>	8–15 mm 15–19 mm 19–22 mm	42.526 42.528 42.529
	<p>GK 20 Comfort double overpanel strike box Suitable for corner lock US 10 consisting of two GK 30 with threaded connecting bolt. For use with toughened safety glass (TSG).</p>	8–12 mm	38.526

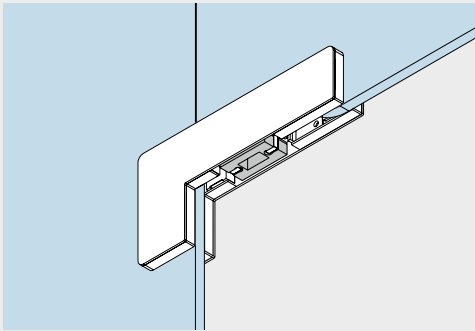
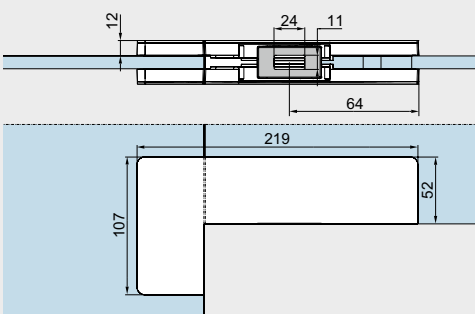
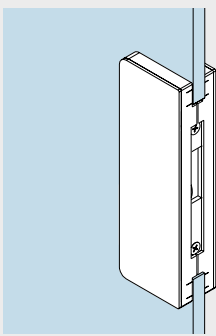
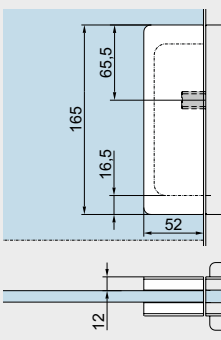
	Product description	Glass thickness	Art. No.
	<p>GK 40 Premium corner overpanel strike box Suitable for corner lock US 10. For use with toughened safety glass (TSG). Also prepared for use with laminated safety glass (LSG) – separate gaskets required.</p> <p>Please note: The load-bearing capability of the overpanel (fan light) is only ensured when using suitable wall connection profiles.</p>	<p>8–15 mm 15–19 mm 19–22 mm</p>	<p>42.540 42.542 42.547</p>
	<p>GK 40 Premium corner overpanel strike box Suitable for corner lock US 10. For use with toughened safety glass (TSG).</p> <p>Please note: The load-bearing capability of the overpanel (fan light) is only ensured when using suitable wall connection profiles.</p>	<p>8–12 mm</p>	<p>38.540</p>
	<p>GK 50 Premium strike box Suitable for center lock US 20. For use with toughened safety glass (TSG). Also prepared for use with laminated safety glass (LSG) – separate gaskets required.</p> <p>With the order please indicate the exact glass thickness!</p>	<p>8–19 mm 19–22 mm</p>	<p>42.550 42.553</p>
	<p>GK 50 Comfort strike box Suitable for center lock US 20. For use with toughened safety glass (TSG).</p> <p>With the order please indicate the exact glass thickness!</p>	<p>8–19 mm</p>	<p>38.550</p>

Installation details (in contrast to UNIVERSAL)

Advisory: Please note that the upper pivots for MUNDUS and those for UNIVERSAL are not mutually compatible. The spigot diameters of the MUNDUS fittings vary.

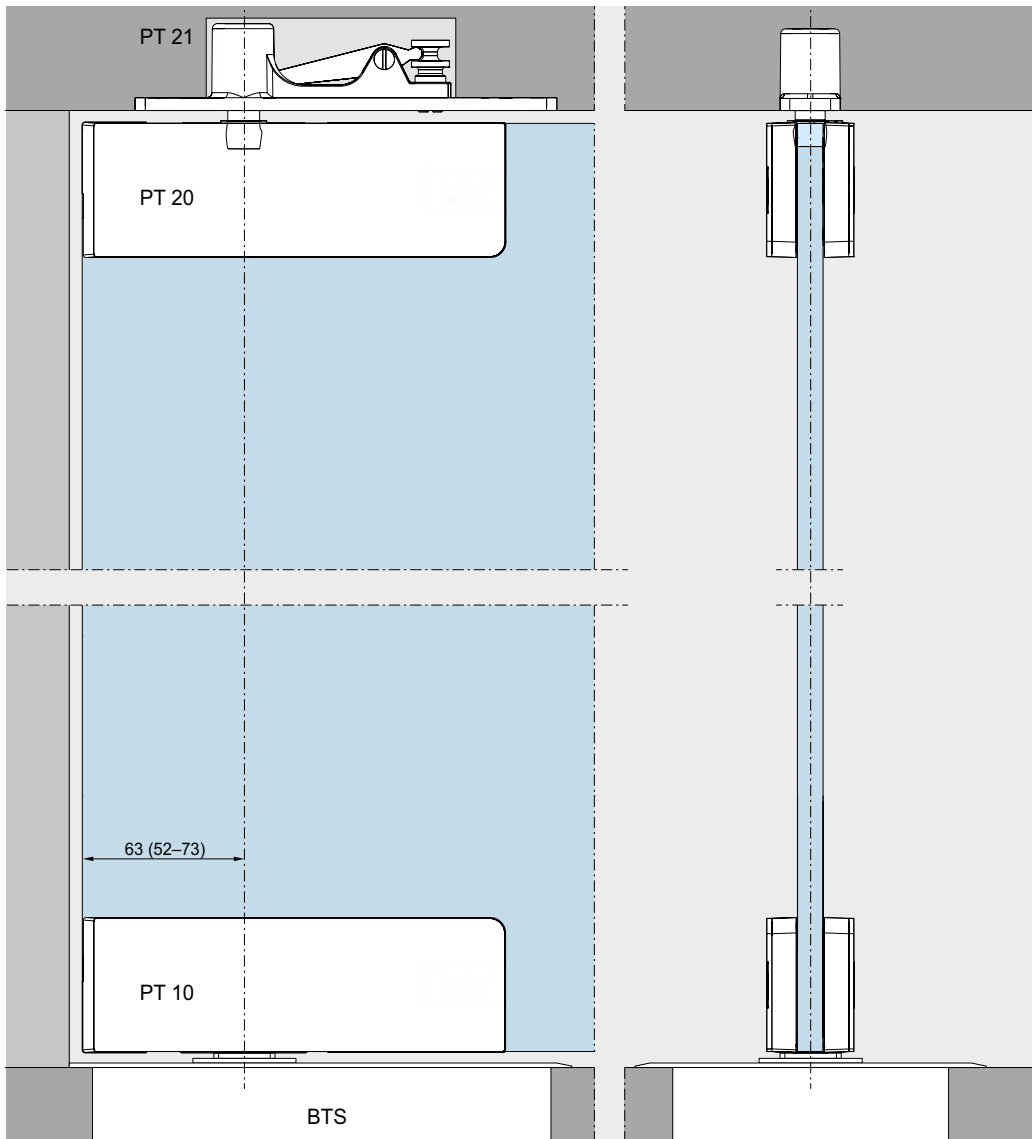
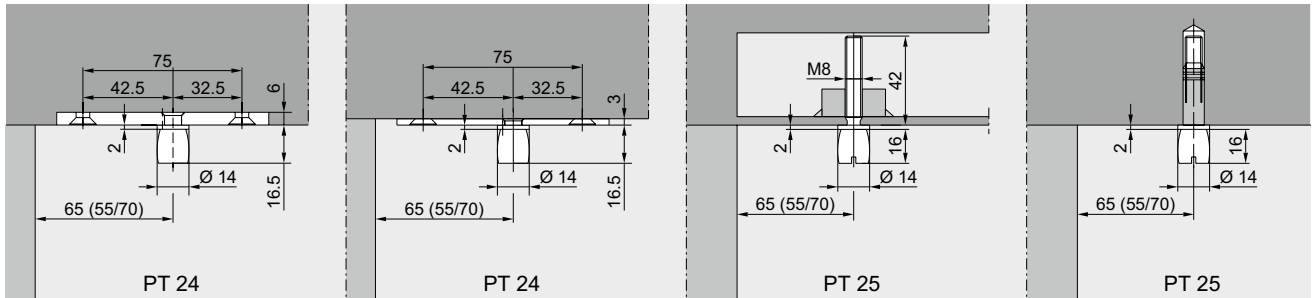

Fixing of top pivots and top centers for PT 20.

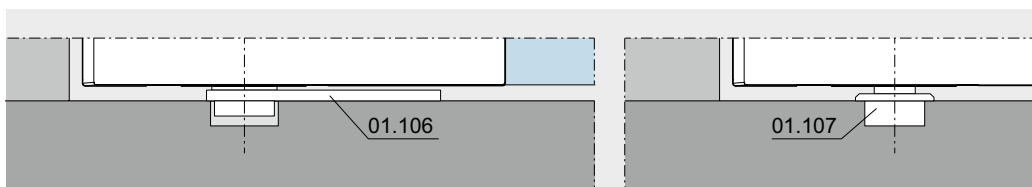

Fixing of floor springs, pivot bearings for PT 10.

Top bearing, pivots for MUNDUS

Advisory: Please note that the upper pivots for MUNDUS and those for UNIVERSAL are not mutually compatible. The spigot diameters of the MUNDUS fittings vary.

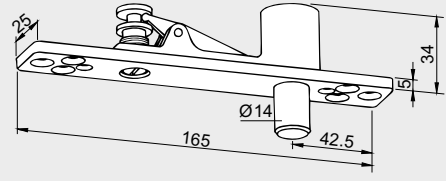
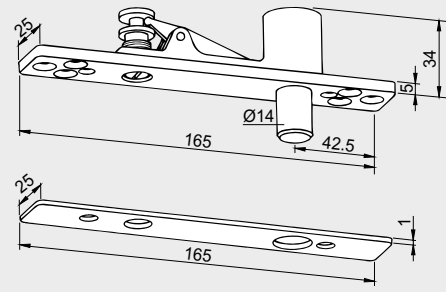
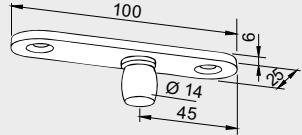
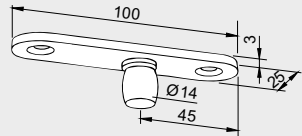
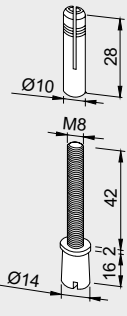
	Product description	Art. No.
	<p>MUNDUS PT 21 frame portion top centre with removable pin</p> <p>Weight in kg: 0.335</p> <p>14 mm Ø</p>	<p>38.210</p>
	<p>MUNDUS PT 21 frame portion top centre with removable pin, with cover plate</p> <p>Weight in kg: 0.345</p> <p>14 mm Ø</p>	<p>38.211</p>
	<p>MUNDUS PT 24 pivot with fixing plate, material thickness 6 mm, to let into ceiling</p> <p>Weight in kg: Aluminum 0.058</p> <p>14 mm Ø</p>	<p>38.240</p>
	<p>MUNDUS PT 24 pivot with fixing plate, material thickness 3 mm, to screw on the ceiling</p> <p>Weight in kg: Aluminum 0.042 Stainless steel 0.074</p> <p>14 mm Ø</p>	<p>38.241</p>
	<p>MUNDUS PT 25 pivot with plug</p> <p>Weight in kg: 0.044</p> <p>14 mm Ø</p>	<p>38.250</p>

Wall connection for MUNDUS

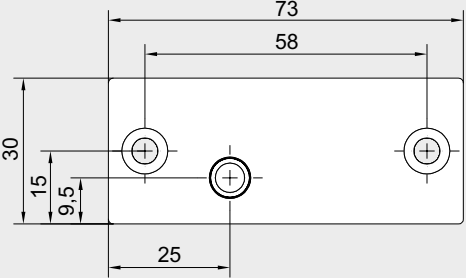
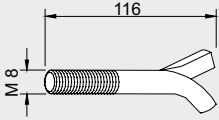
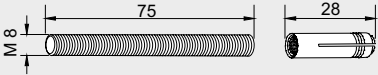
	Product description	Art. No.
	<p>Fixing plate for overpanel patch fitting PT 30 and overpanel strike box GK 30</p> <p>Weight in kg: 0.041</p> <p>Not available in brass or aluminum.</p>	<p>38.313</p>
	<p>Wall anchor with thread M 8 for overpanel patch</p> <p>Weight in kg: 0.040</p>	<p>01.133</p>
	<p>Threaded rod M 8 with plug for overpanel patch</p> <p>Weight in kg: 0.032</p>	<p>01.134</p>

Floor bearing, lock keeper plate, floor socket for MUNDUS

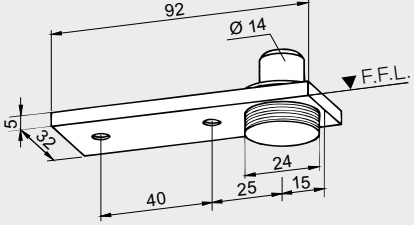
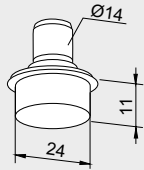
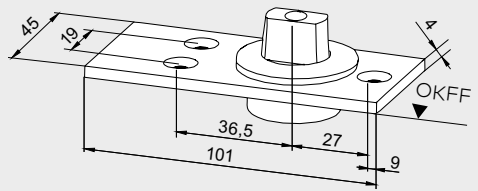
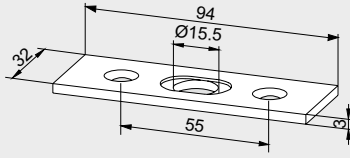
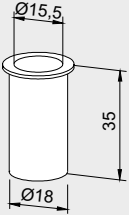
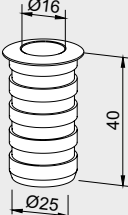
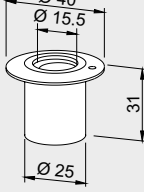
	Product description	Art. No.
	<p>Floor pivot bearing with round pivot 14 mm Ø, and cover plate; height adjustable by 5 mm max. door weight 100 kg</p> <p>Weight in kg: Aluminum 0.155 Brass 0.170 Stainless steel 0.169</p>	01.106
	<p>Floor pivot bearing with round pivot 14 mm Ø and pin 24 mm Ø max. door weight 100 kg</p> <p>Weight in kg: 0.078</p>	01.107
	<p>Floor bearing with profile spindle (longer spindle on request), max. door weight 200 kg</p> <p>Stainless steel, max. door weight 200 kg</p> <p>Weight in kg: 0.254</p>	04.602 04.603
	<p>Lock keeper plate, stainless steel, two parts, adjustable ± 5 mm</p> <p>Weight in kg: 0.048</p>	05.190
	<p>Floor socket, zinc coated brass for lock bolt</p> <p>Weight in kg: 0.020</p>	05.192
	<p>Floor socket, aluminum, with spring and plastic stopper, dirt protection</p> <p>Weight in kg: 0.026</p>	05.193
	<p>Eccentric socket, eccentric, zinc coated brass, with adjustable plastic socket insert</p> <p>Weight in kg: 0.020</p>	05.194

Accessories for use with laminated safety glass

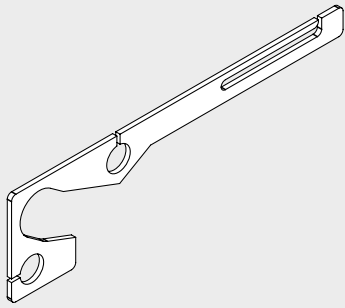
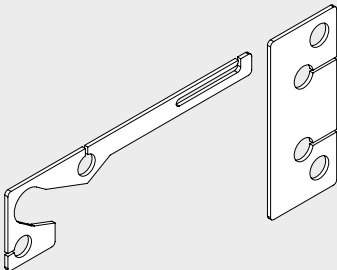
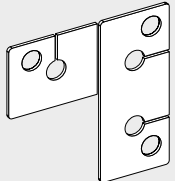
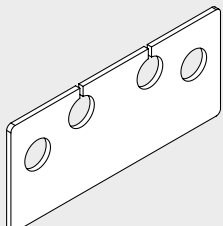
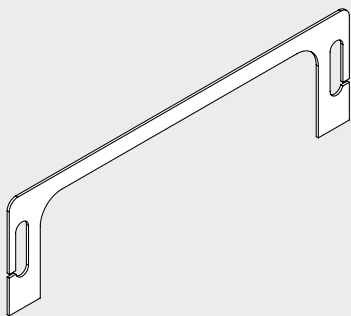
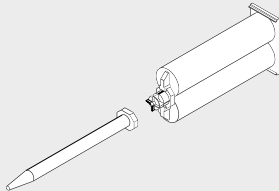
	Product description	Art. No.
	MUNDUS Premium LSG gaskets PT 10/20/30/GK 30 LSG glue 07.631 is needed	42.951
	MUNDUS Premium LSG gaskets PT 40 LSG glue 07.631 is needed	42.952
	MUNDUS Premium LSG gaskets PT 60 LSG glue 07.631 is needed	42.953
	MUNDUS Premium LSG gaskets PT 70 LSG glue 07.631 is needed	42.954
	MUNDUS Premium LSG gaskets US 10/20/GK 50 LSG glue 07.631 is needed	42.955
	Glue and nozzle for LSG	07.631

Glass preparation patch fittings

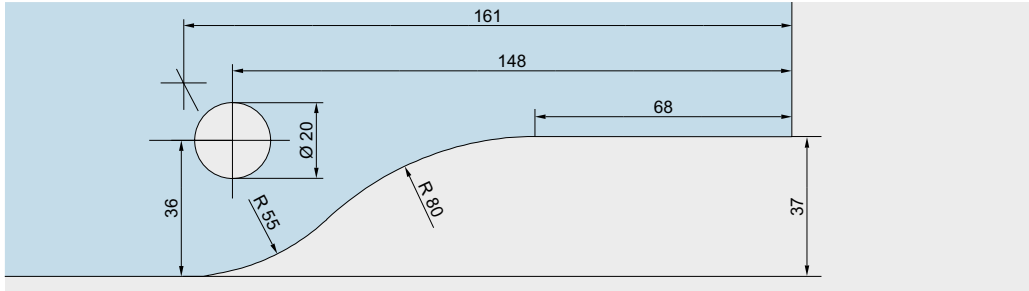

**PT 10, PT 20,
PT 22, PT 30**
Top and bottom
patches,
overpanel patch

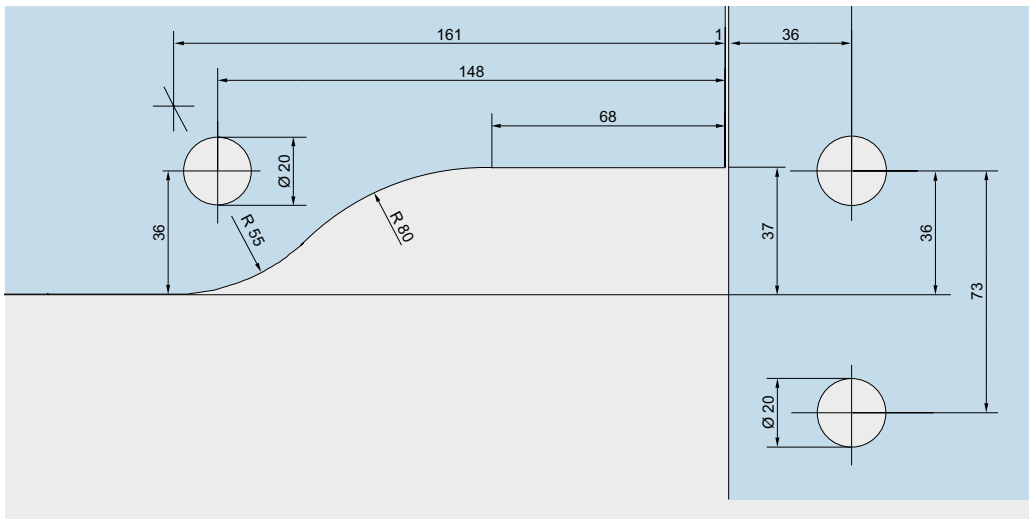

PT 40
Patch for
overpanel and
sidelight

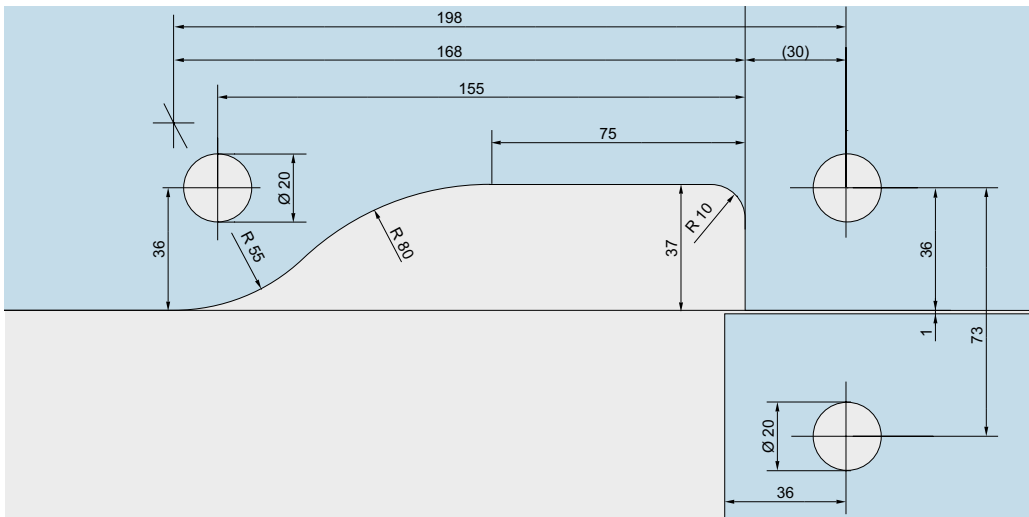

PT 40
Angle patch fitting
with continuous
overpanel

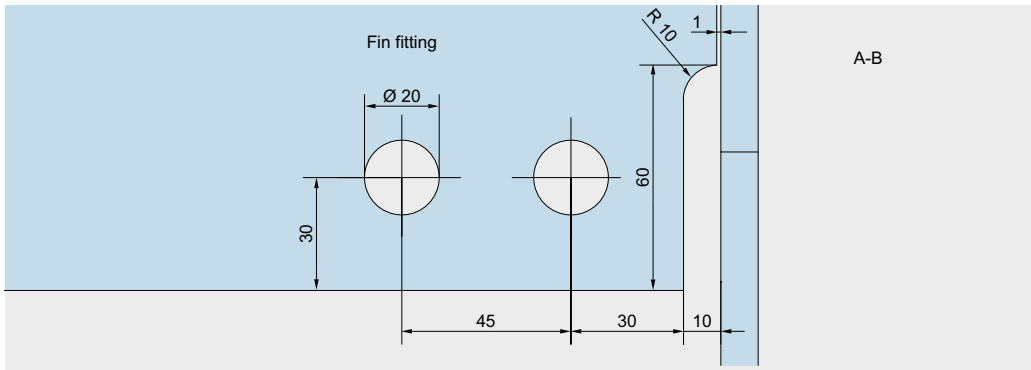

PT 41
Patch for overpanel and sidelight with fin fitting inside

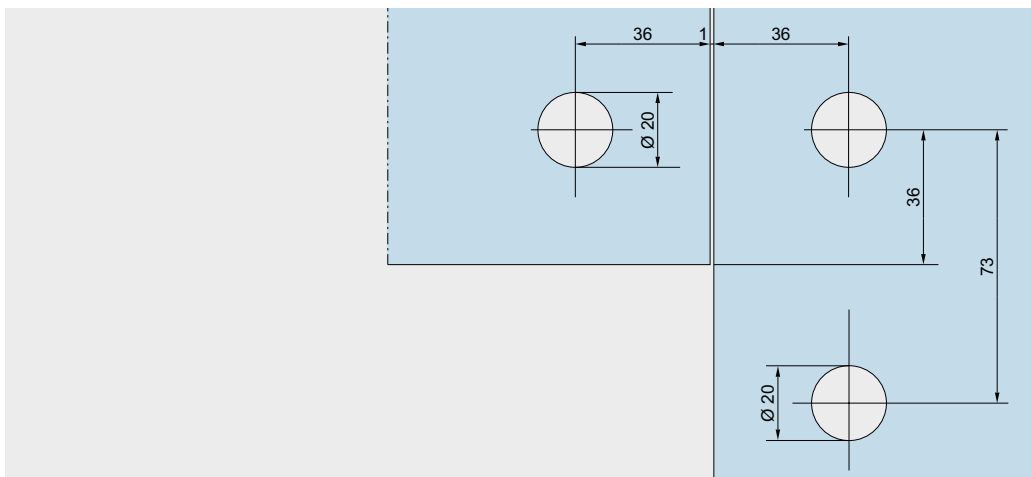
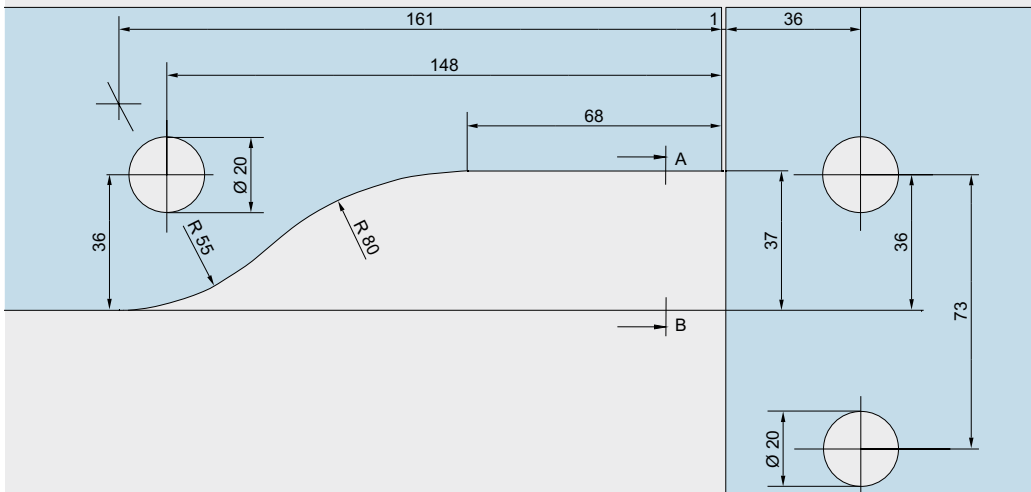

PT 60
Connectors for overpanels and sidelights

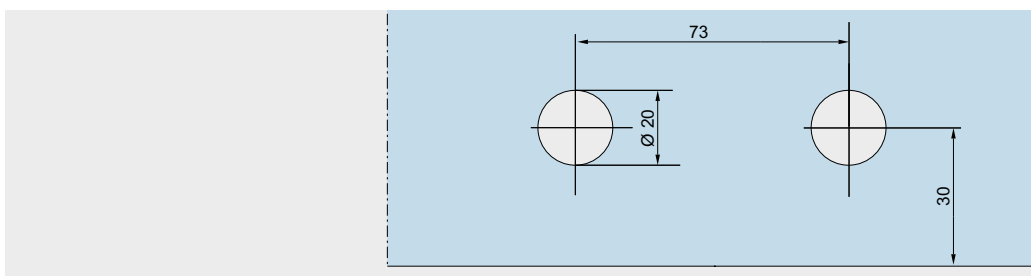

PT 70
Overpanel connector

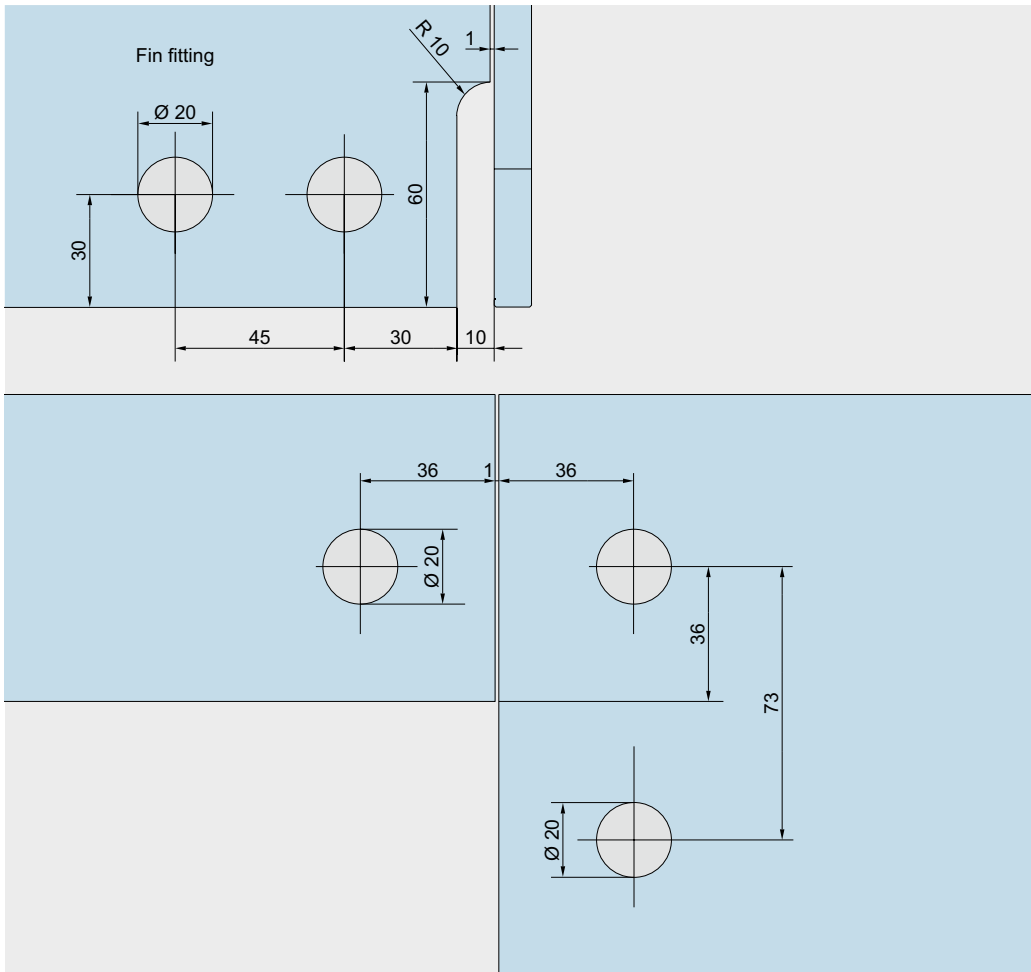

PT 61

Single overpanel
connector
with fin fitting
inside

Glass preparation locks and strike boxes

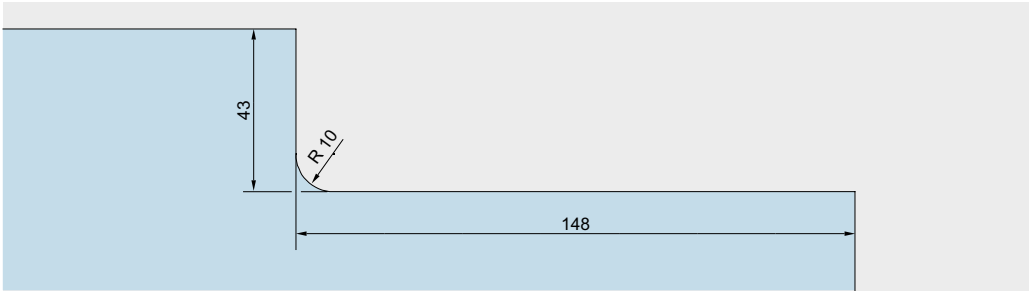

US 10
Corner locks

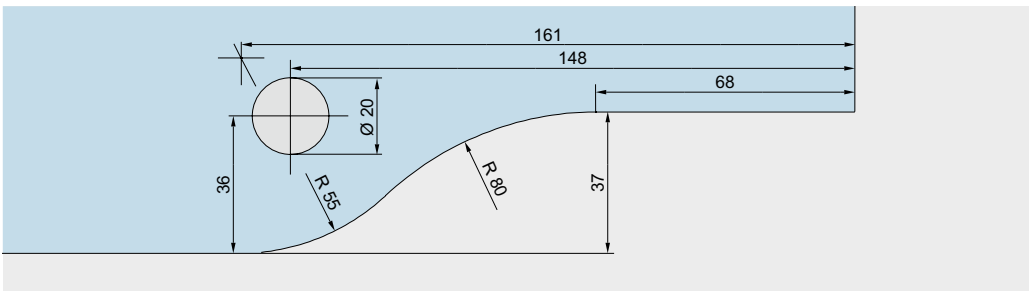

GK 30 (PT 30)
Single overpanel strike box

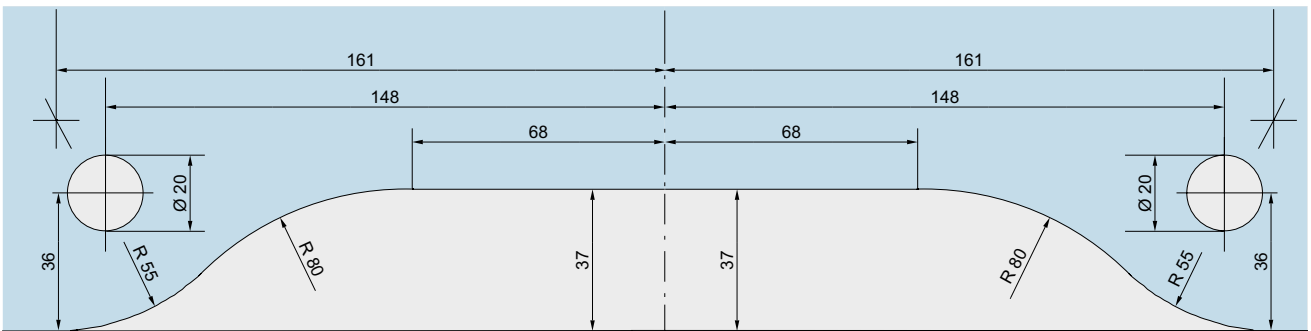

GK 20
Double overpanel strike box

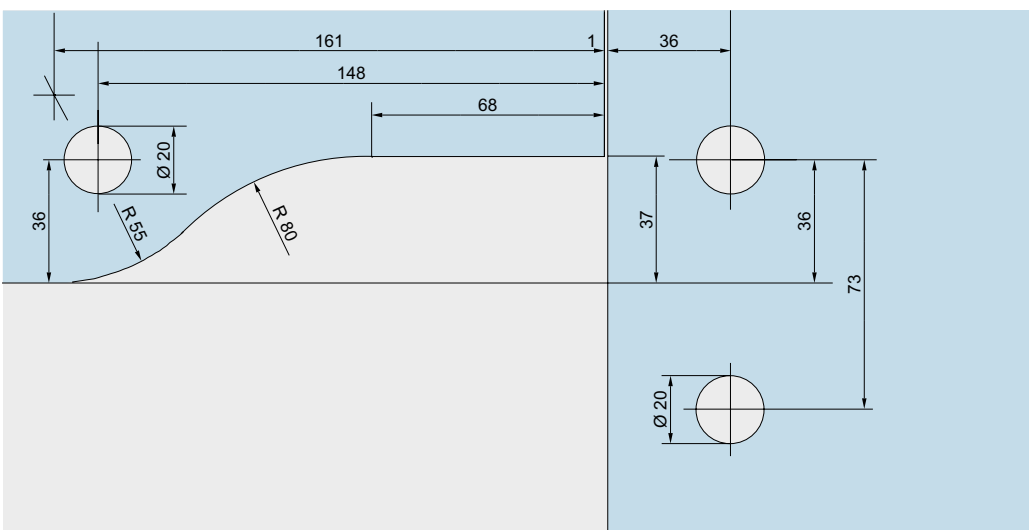

GK 40 (PT 40)
Corner overpanel strike box

Product description

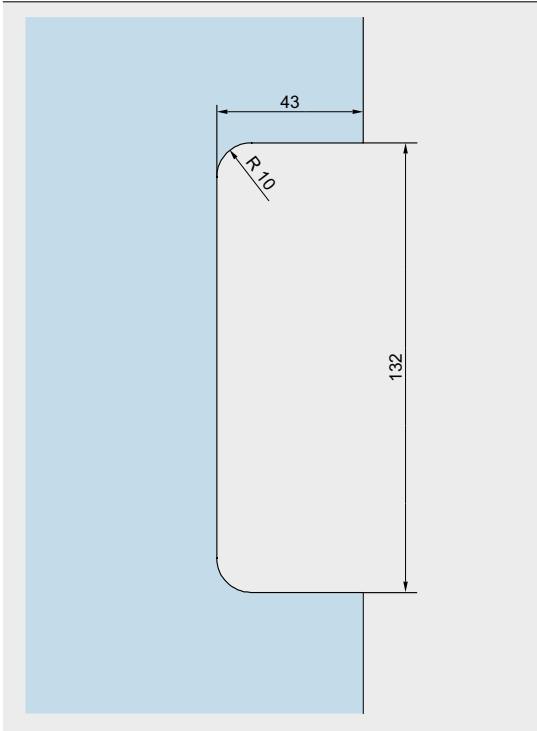

US 20, GK 50

Center lock and strike box to suit center lock

Space for your notes

Content

UNIVERSAL

42	General information
44	Type illustration
48	Components
60	Glass preparation
70	Installation details
188	Accessories
212	Safety-related information



UNIVERSAL

UNIVERSAL ... as the name says

With its broad spectrum of basic types and variants, the UNIVERSAL range of patch fittings enables the realisation in toughened glass of almost any conceivable design. Toughened glass assemblies can be provided with fixed parts in widely differing arrangements – with corner fittings or fin fittings at different angles, and with double or single-action doors in single-leaf or double-leaf designs.

Easy glass preparation, secure fixing

dormakaba has an intimate knowledge of the special properties of glass as a building material. This has led to the design of fittings requiring only minimal glass preparation – a quick and easy cut-out with additional holes. Carefully considered and positive measures have been taken to create the maximum clamping surface with optimum clamping efficiency.

Suitable for common glass thicknesses

UNIVERSAL fittings are supplied as standard with gasket to suit 10 mm glass (TSG). For 8 mm and 12 mm glass, correspondingly thicker and thinner gasket is available. Some patches are even designed to fit directly with different glass thicknesses.

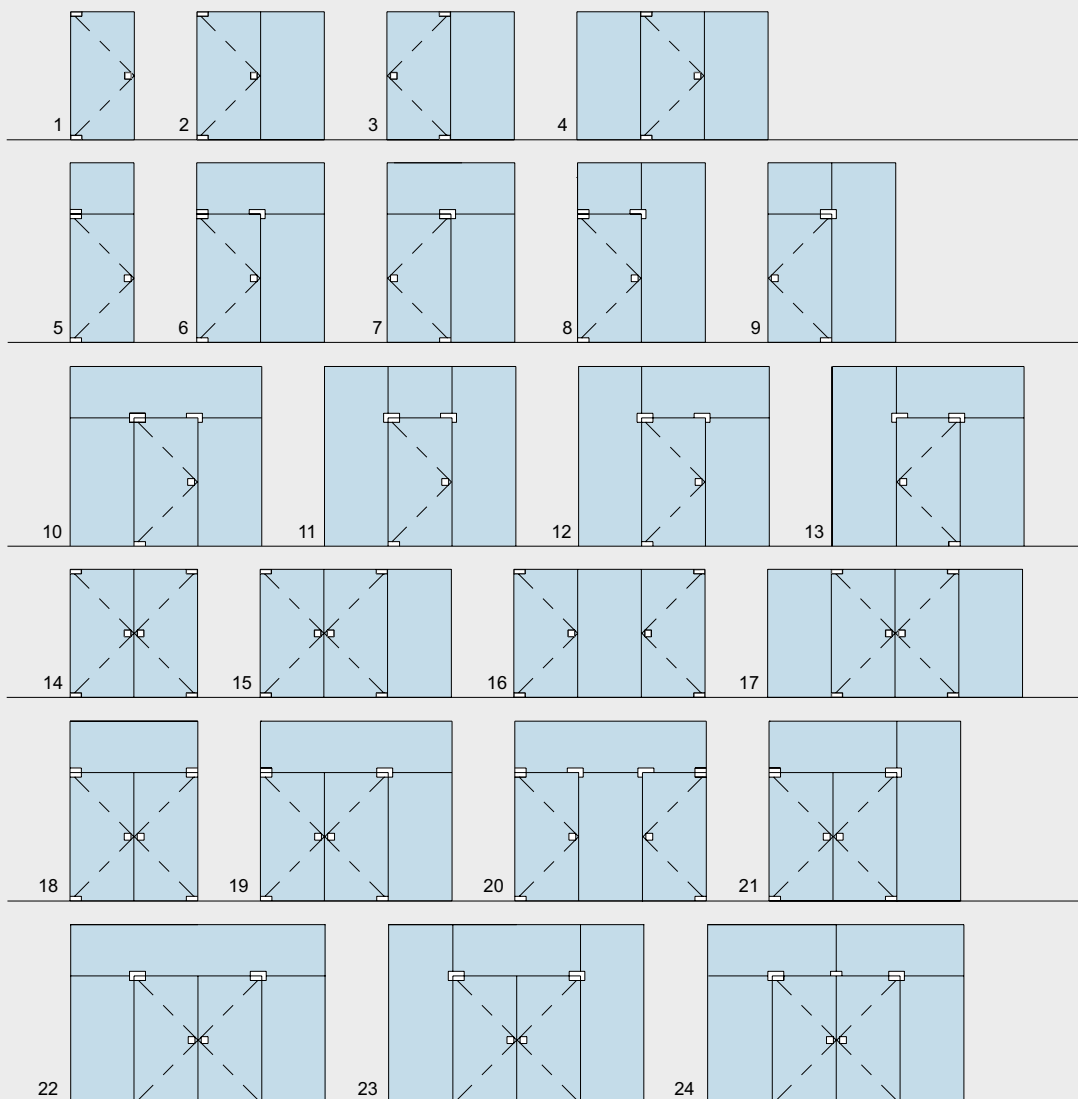

Variable pivot point

The inserts for corner and overpanel patches in the UNIVERSAL program have been designed and manufactured to give two options in the pivot point distance from the sidepanel or frame. It can be either 55 mm or 65 mm. At 65 mm pivot point and the use of a special round profile (page 124) doors can be built with a constant air gap of only 4 mm.

For information regarding patch fittings UNIVERSAL with 15 mm pivot point for pinch free doors see page 62 and following pages.

Reliability built in

Quality materials and thorough workmanship mean that UNIVERSAL fittings have the features necessary to meet the most demanding of specifications. The fittings are designed to cope with large and heavy doors up to a maximum weight of 110 kgs: for instance, a door blade 3,000 mm high by 1,100 mm wide, using 12 mm glass is quite possible.

Please contact our Application Engineering department for more information. For heavier and wider doors up to a maximum of 150 kg and max. 1,400 mm and for high frequented doors, rails with reinforced straps are available.

Matching range of locks

The UNIVERSAL range includes every type of accessory, and of course, a variety of locks and strike boxes in a matching design concept, giving the designer plenty of choice from the options available.

Short delivery times

All the common patterns and types are available ex-stock (factory). Specials will be prepared promptly.

Type section

Toughened glass assemblies with fittings (55/65 mm pivot point) and locks.
All standard assembly types see page 42.

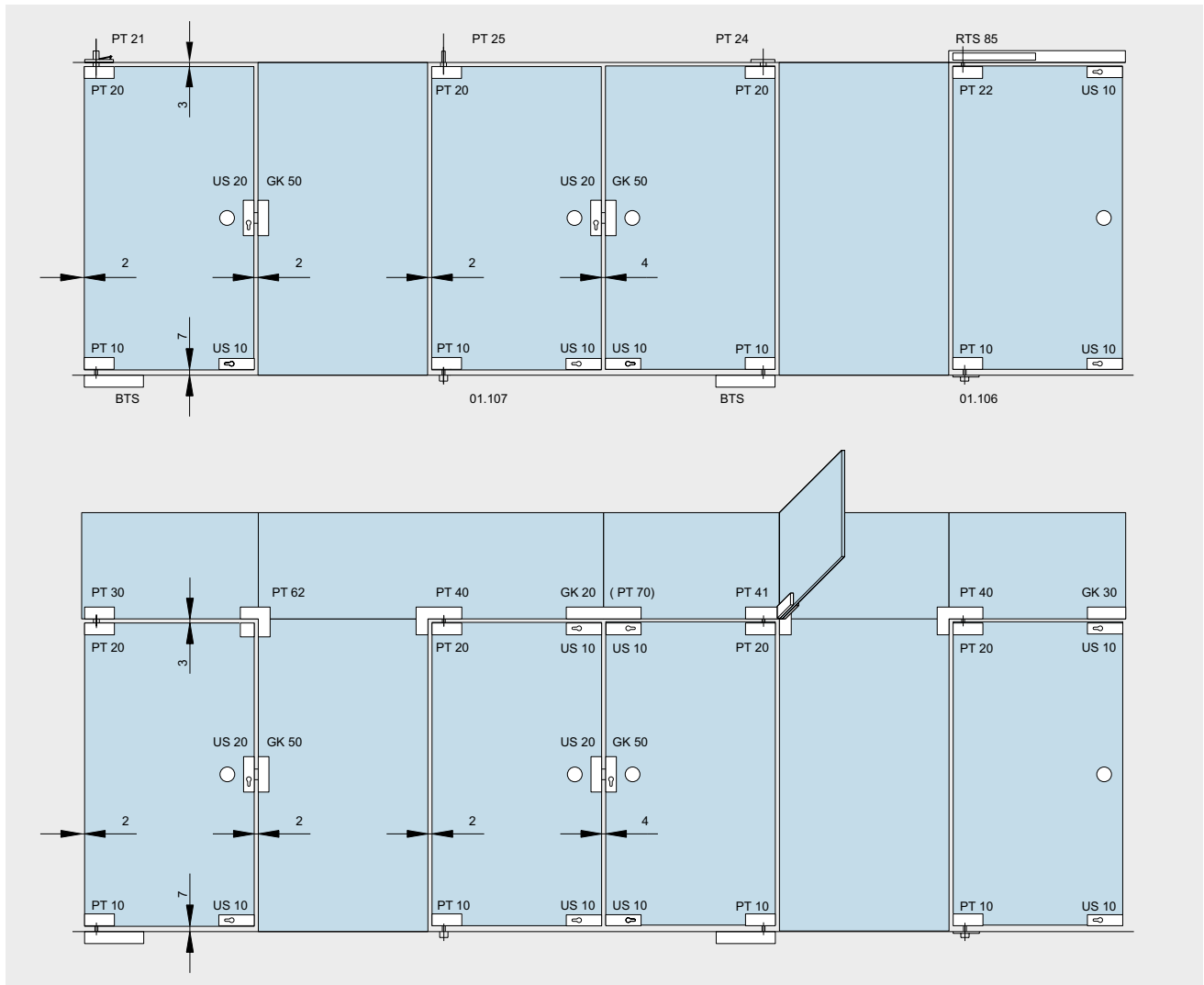

- | | | | | | |
|-----|----------------|-----|-----------------------------|----|--------|
| BTS | = Floor spring | PT | = Centre hung door fittings | US | = Lock |
| GK | = Strike box | RTS | = Transom closer | | |

Maximum door weight and width for UNIVERSAL fittings

max. door weight: 110 kg*
 max. door width: 1,100 mm**

For doors with higher frequency and in public areas we would advise to use a door rail for doors above 110 kg and door width larger than 1,100 mm. For door weights up to 150 kg and widths up to 1,400 mm door rails should be used.

* For door heights up to 2,500 mm

- For doors with a height of more than 2,500 mm we have to keep additional conditions/limits:
- Glass thickness >/= 10 mm
 - + Usage of a handle bar with 3 connection points in minimum and a minimum height of 1/2 door height

** Use of door closers:

Doors < / = 1,100 mm must be provided with door closers of type EN 3 (with or without backcheck), and doors > / = 1,100 mm need to be fitted with larger door closers (e.g. EN 4, 5 or 6) without backcheck.

Torque for fixing screws

Screws M 6: 10 Nm (4 mm)*

Screws M 6: 15 Nm (5 mm)*

Screws M 8: 20 Nm (5 mm)*

*Allan key size

Please note: If angle fittings or fin fittings are used:

"Left" or "Right" have to be determined in any case by view from outside and above.

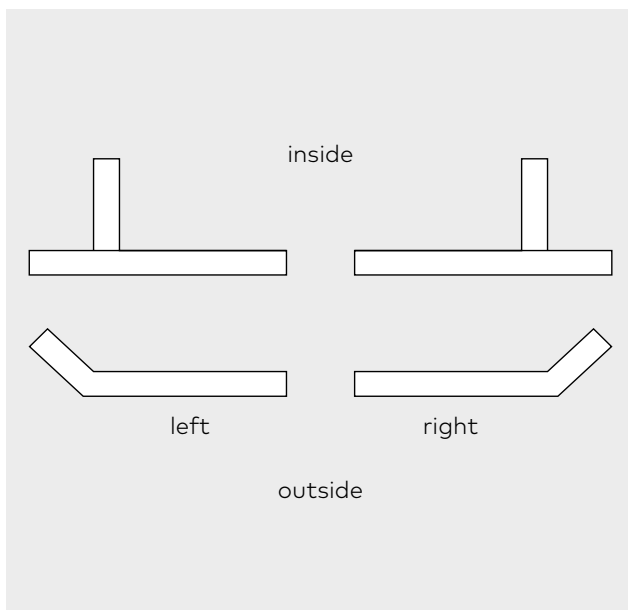

UNIVERSAL Motion – the self-closing patch fitting

A patch fitting with hydraulic self-closing function is not just convenient but also efficient: The hydraulic technology proves its advantage without requiring a power supply and any visible mechanism. UNIVERSAL Motion is like a reliable employee with intrinsic values: the space-saving technology is integrated in the compact bottom patch fitting and does not require any additional installation space.

Eight reasons for the one.

- **Completely smart.** In UNIVERSAL Motion, the door closing function is integrated in a compact, well-shaped unit. A subtly functional design.
- **Almost invisible.** What looks like a patch fitting manages the closing of doors by itself. An additional floor spring is not required.
- **Clear savings.** Less effort and cost-efficient. You need only two fittings for the self-closing swing door: UNIVERSAL Motion and PT 20.
- **Comfortable function.** The door closes softly by itself. The hydraulic door movement is achieved simply in the fitting – without extra installation, without power supply.
- **Simple installation.** UNIVERSAL Motion consists of very few parts. The glass door is clamped in the fitting. No prior changes to the floor are required.
- **For the existing building.** Retrofitting is clearly simpler than before. The floor need not be sawn nor milled beforehand.
- **Simple positioning.** The material and composition of the floor are not critical factors. You need to place only four vertical bores for the bottom pivot bearing.
- **Different surface finishes.** The dormakaba colour palette creates systematic diversity. The colour spectrum corresponds to the standard UNIVERSAL fittings. A custom-made colour scheme as per RAL is also possible. Simply matches the contemporary interior.

* Door widths smaller than 650 mm can be realized from a product technical point of view. However, this is not recommended, as the opening forces to be applied then lie outside the DIN 12217 standard.



Technical features:

Glass thickness: 10 + 12 mm ESG
 Door width: von 650 mm bis 1000 mm*
 Door height: max. 3000 mm
 Door weight: max. 100 kg
Pivot point: 67 mm

The screw depth in the bottom of the supplied screws for the floor pivot bearing is 65 mm.

Available in the surface variants stainless steel and aluminium, as well as the product variants with 90 degree hold-open (Tolerance window: +/- 3 degrees) and without hold-open.

UNIVERSAL Motion is intended for indoor use. The fitting is not suitable for outdoor applications and for doors in high-frequency areas / public buildings.

UNIVERSAL Motion is tested by dormakaba according to DIN EN 1191:2013 for 300,000 test cycles.

Technical notes:

The 90-degree detection has a tolerance range of +/- 3 degrees due to the manufacturing process.

Due to insufficient pressure equalisation within the rooms, the door can lose its zero position when closed, caused by pressure or suction loads. This is due to the environment or external influences and does not represent a product defect. All spring-supported and hydraulic closing devices are affected. The problem can only be mitigated or avoided by creating significantly larger and stronger floor springs (e.g. BTS 80) can be used (depending on the wind loads).

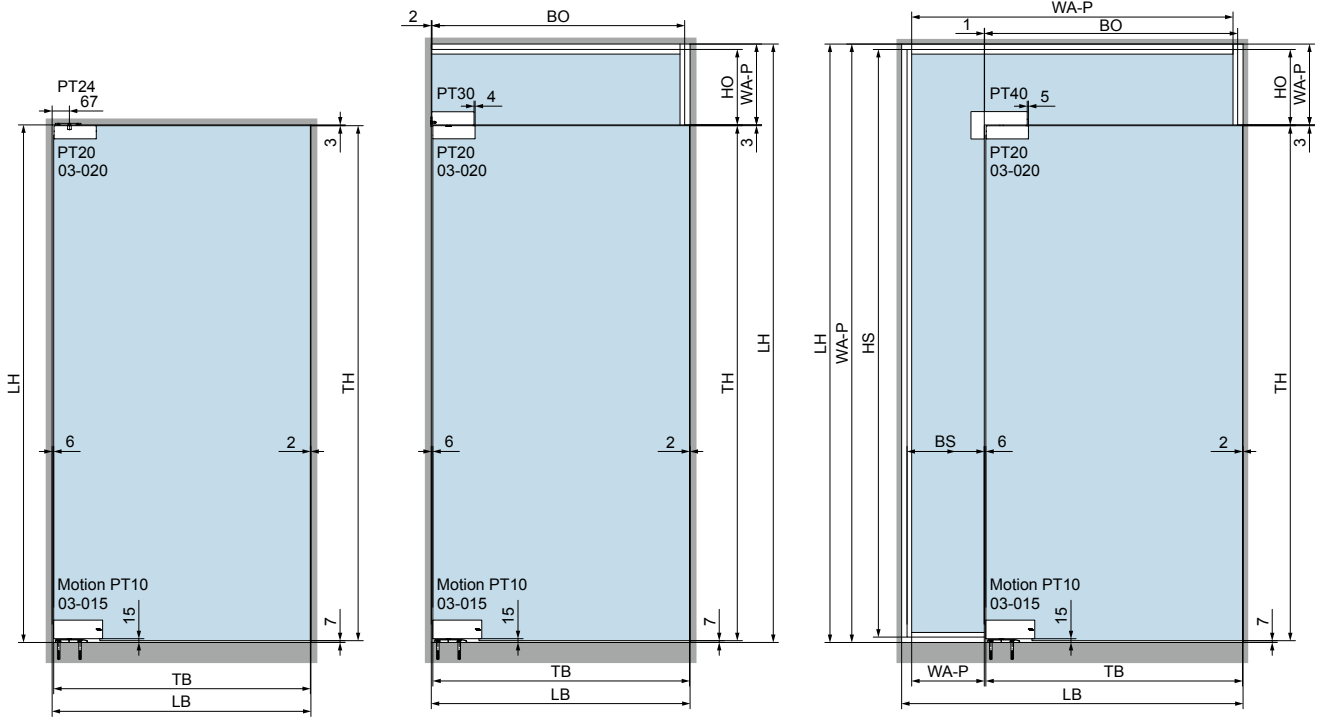

TH = Door height
 TB = Door width
 LH = Clear height

LB = Clear width
 WA-P = Length WA-P
 HS = Height side panel

BS = Width side panel
 HO = Height overpanel
 BO = Width overpanel

Hint:

To extend the tolerance range, it is possible to increase the glass bore for the PT20 from $\varnothing 20$ to $\varnothing 22$.

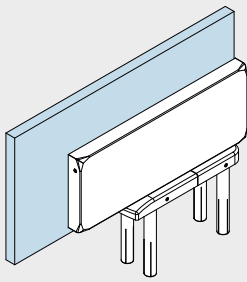
	Produktbeschreibung	Glasdicke	Art.-Nr.
	<p>UNIVERSAL Motion, lower corner fitting with hydraulic door closing function, including floor pivot bearing and fixing material</p>		
	<p>with 90 degrees hold-open</p>	<p>10 + 12 mm</p>	<p>03.108</p>
	<p>without hold-open</p>	<p>10 + 12 mm</p>	<p>03.109</p>
<p>Weight in kg: Aluminum: 2,211 Satin stainless steel: 2,413</p>			

Patch fittings

Shown with 10 mm glass. From 12 mm glass the measurements change accordingly. Accessories see page 188 and following.

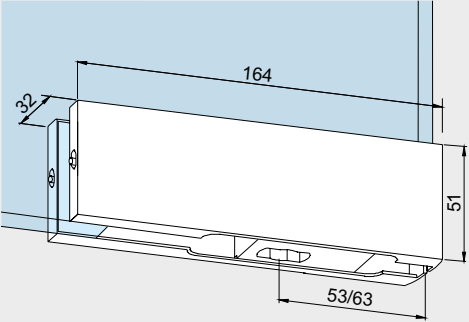
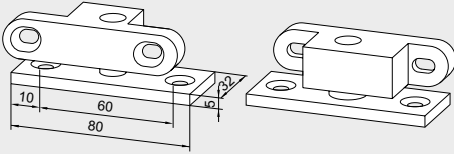
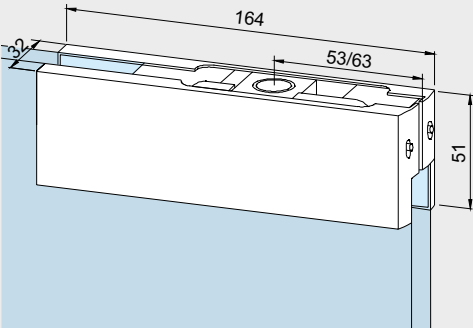
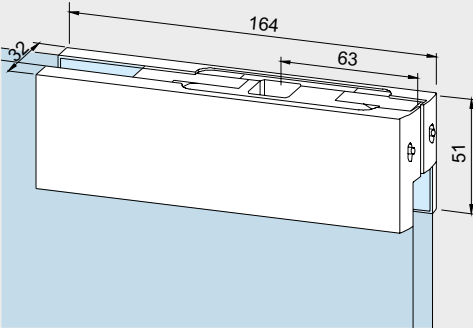
	Product description	Glass thickness	Art. No.
	<p>PT 10 UNIVERSAL Bottom patch with insert for floor spring spindle, or round pivot 14 mm Ø</p> <p>With the order please indicate the exact glass thickness!</p> <p>Weight in kg: Aluminum 0.564 Brass 0.680 Stainless steel 0.662</p>	10 mm 13 - 19 mm	*03.100 03.280
	<p>Floor pivot bearing for damp environments, with insert for PT 10 UNIVERSAL without floor recess, max. door weight 80 kg</p> <p>Weight in kg: 0.195</p> <p>Only for UNIVERSAL applications, not suitable for MUNDUS.</p>	10 mm	01.137
	<p>PT 20 UNIVERSAL Top patch with plastic socket for top pivot 15 mm Ø</p> <p>With the order please indicate the exact glass thickness!</p> <p>Weight in kg: Aluminum 0.477 Brass 0.593 Stainless steel 0.575</p>	10 mm 13 - 19 mm	*03.110 03.281
	<p>PT 22 UNIVERSAL Top patch with insert for RTS transom closer</p> <p>Weight in kg: Aluminum 0.578 Brass 0.695 Stainless steel 0.677</p>	10 mm	03.112

* Suitable gaskets have to be used for systems with an 8 or 12 mm glass thickness. These are available on page 196.

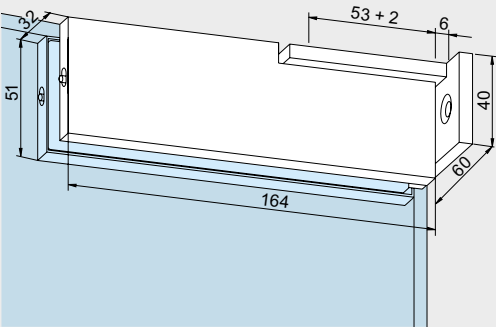
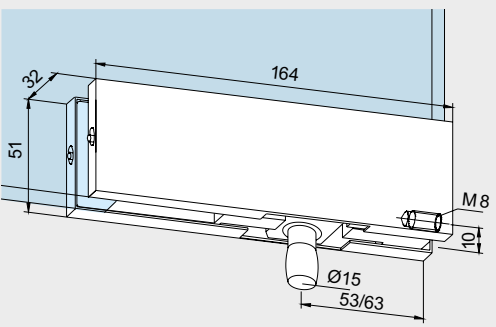
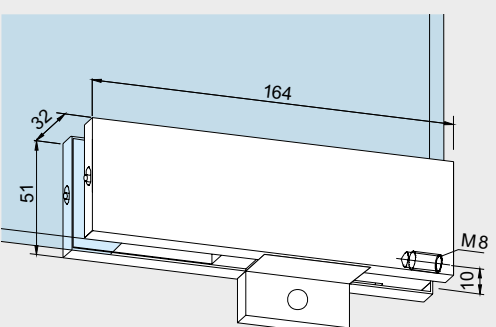
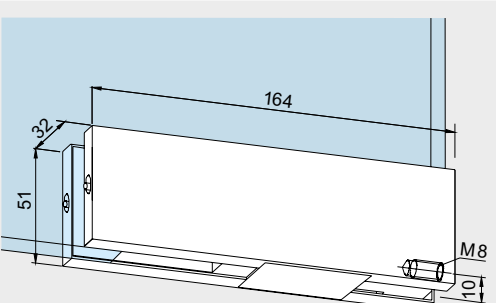
	Product description	Glass thickness	Art. No.
	<p>PT 29 UNIVERSAL Top patch with pivot fixing plate, to countersink into ceiling (pivot point = 55 mm)</p> <p>max. door width: 1,000 mm max. door weight: 70 kg</p> <p>Weight in kg: Aluminum 0.544 Brass 0.692</p>	<p>10 mm</p>	<p>03.114</p>
	<p>PT 30 UNIVERSAL Overpanel patch with pivot 15 mm Ø, with M8 tapped hole at the side</p> <p>With the order please indicate the exact glass thickness!</p> <p>Weight in kg: Aluminum 0.528 Brass 0.654 Stainless steel 0.636</p>	<p>10 mm 13 - 19 mm</p>	<p>*03.120 03.282</p>
	<p>PT 30 UNIVERSAL Overpanel patch with stop insert</p> <p>With the order please indicate the exact glass thickness!</p> <p>Weight in kg: Aluminum 0.528 Brass 0.654 Stainless steel 0.580</p>	<p>10 mm 13 - 19 mm</p>	<p>*03.420 03.482</p>
	<p>PT 30 UNIVERSAL Overpanel patch with blank insert</p> <p>With the order please indicate the exact glass thickness!</p> <p>Weight in kg: Aluminum 0.519 Brass 0.645 Stainless steel 0.571</p>	<p>10 mm 13 - 19 mm</p>	<p>*03.421 03.484 not illustrated</p>

* Suitable gaskets have to be used for systems with an 8 or 12 mm glass thickness. These are available on page 196.

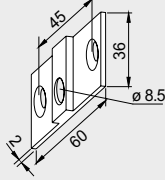
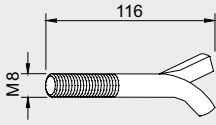
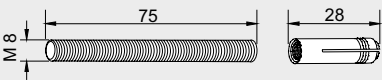
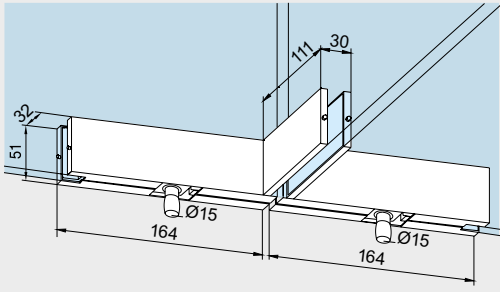
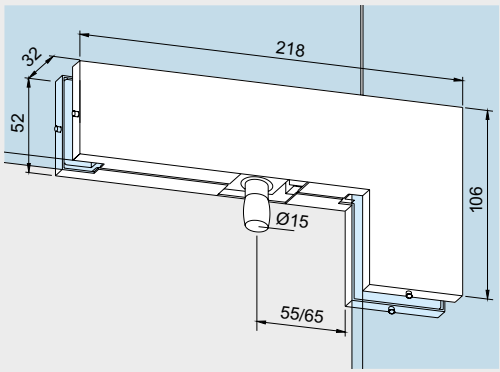
	Product description	Glass thickness	Art. No.
	<p>Fixing plate for overpanel patch PT 30 UNIVERSAL</p> <p>Weight in kg: Aluminum 0.016 Brass 0.038</p> <p>Stainless steel not available, satin chrome on brass supplied.</p>		03.128
	<p>Wall anchor with thread M 8 for overpanel patch PT 30</p> <p>Weight in kg: 0.040</p>		01.133
	<p>Threaded rod M 8 with plug for overpanel patch PT 30</p> <p>Weight in kg: 0.032</p>		01.134
	<p>PT 51 UNIVERSAL Double overpanel fitting with fin fitting on one side and 2 pins 15 mm diameter Usable for glass thicknesses up to 12 mm. If thicker glasses are required, please talk to our Application Engineering people.</p> <p>Weight in kg: Aluminum 1.299 Stainless steel 1.576</p>	10 mm	03.160
	<p>PT 40 UNIVERSAL Patch for overpanel and sidelight with pivot 15 mm Ø</p> <p>With the order please indicate the exact glass thickness!</p> <p>Weight in kg: Aluminum 0.755 Brass 0.958 Stainless steel 0.937</p>	10 mm 13 - 19 mm	*03.140 03.283 not illustrated

* Suitable gaskets have to be used for systems with an 8 or 12 mm glass thickness. These are available on page 196.

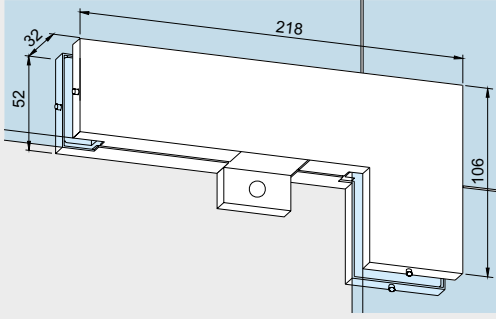
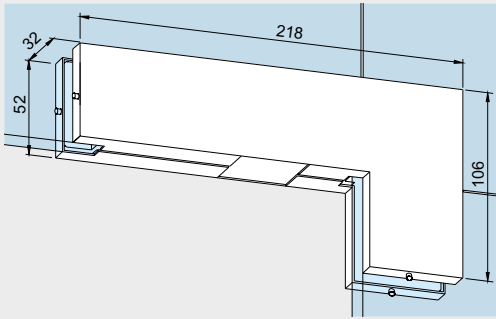
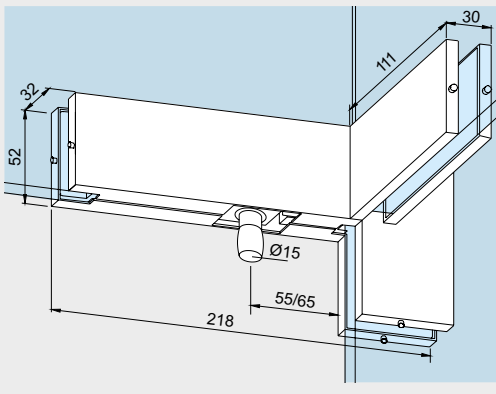
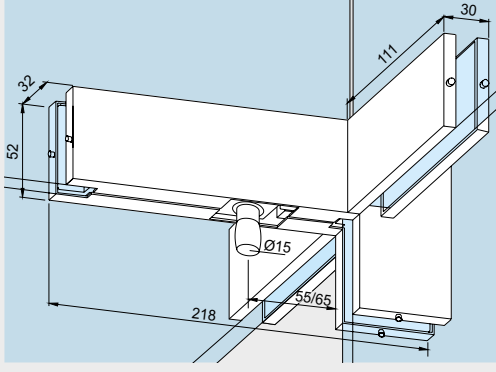
	Product description	Glass thickness	Art. No.		
	<p>PT 40 UNIVERSAL Patch for overpanel and sidelight with stop insert</p>	<p>10 mm 13 - 19 mm</p>	<p>*03.440 03.483 not illustrated</p>		
<p>With the order please indicate the exact glass thickness!</p>	<p>Weight in kg: Aluminum 0.755 Brass 0.958 Stainless steel 0.937</p>	<p>PT 40 UNIVERSAL Patch for overpanel and sidelight with blank insert</p>	<p>10 mm 13 - 19 mm</p>	<p>*03.441 03.485 not illustrated</p>	
	<p>With the order please indicate the exact glass thickness!</p>	<p>Weight in kg: Aluminum 0.746 Brass 0.949 Stainless steel 0.928</p>	<p>PT 41 UNIVERSAL Patch for overpanel and sidelight with fin fitting inside, with pivot 15 mm Ø</p>	<p>10 mm</p>	<p>**03.162/ 03.163</p>
	<p>PT 41 UNIVERSAL Patch for overpanels and sidelight with stop insert</p>	<p>10 mm</p>	<p>**03.262/ 03.263 not illustrated</p>		
<p>Weight in kg: Aluminum 0.952 Stainless steel 1.197</p>		<p>PT 41 UNIVERSAL Patch for overpanels and sidelight with fin fitting on both sides, with pivot 15 mm Ø</p>	<p>10 mm</p>	<p>03.161</p>	
<p>Weight in kg: Aluminum 1.149 Stainless steel 1.457</p>	<p>* Suitable gaskets have to be used for systems with an 8 or 12 mm glass thickness. These are available on page 196. ** Left hand fin (illustration shows left hand) / right hand fin. Left or right hand are determined by view from outside.</p>				

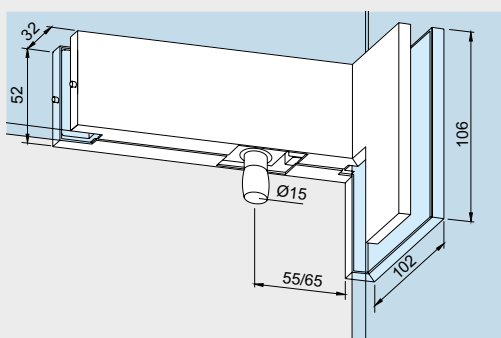
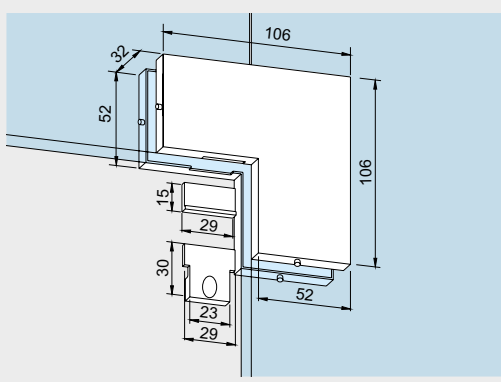
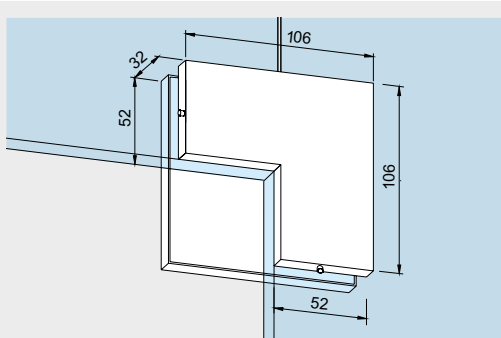
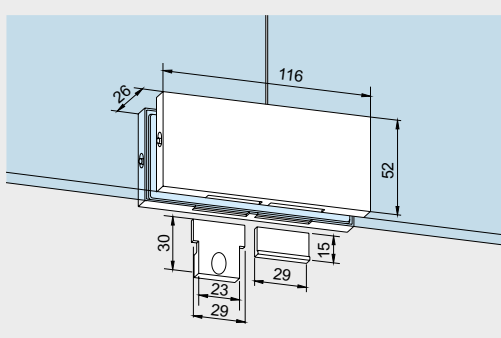
	Product description	Glass thickness	Art. No.
	<p>PT 42 UNIVERSAL Overpanel patch for single action doors with angled connector inside, pivot 15 mm, angle 90°</p>		<p>**03.164/ 03.165</p>
	<p>PT 60/61 UNIVERSAL Connector for overpanel and sidelight, for double or single action doors with one stop insert and two blank inserts, also suitable for 12 mm glass thickness.</p> <p>With the order please indicate the exact glass thickness!</p> <p>Weight in kg: Aluminum 0.343 Brass 0.461 Stainless steel 0.436</p>	<p>10 mm 13 - 19 mm</p>	<p>*03.150 03.452 not illustrated</p>
	<p>PT 62 UNIVERSAL Connector for overpanel and sidelight, with stop</p> <p>Weight in kg: Aluminum 0.475 Stainless steel 0.670</p>		<p>03.173</p>
	<p>PT 70 UNIVERSAL Overpanel connector with two stop inserts and two blank inserts, also suitable for 12 mm glass thickness</p> <p>With the order please indicate the exact glass thickness!</p> <p>Weight in kg: Aluminum 0.272 Stainless steel 0.335</p>	<p>13 - 19 mm</p>	<p>*01.150 01.158 not illustrated</p>

* Suitable gaskets have to be used for systems with an 8 or 12 mm glass thickness. These are available on page 196.

** Left hand fin (illustration shows left hand) / right hand fin. Left or right hand are determined by view from outside.

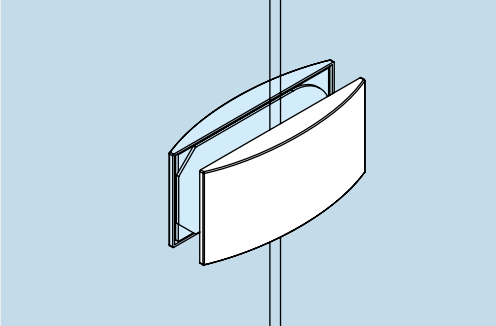
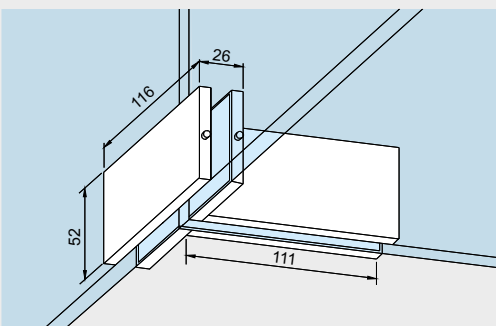
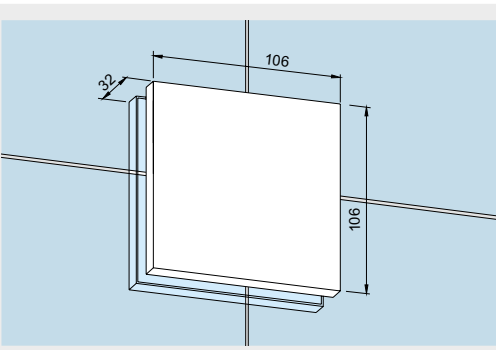
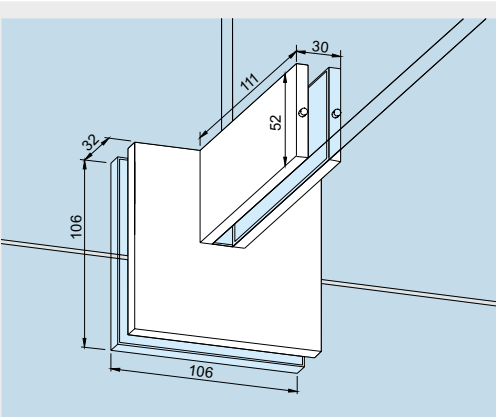
	Product description	Glass thickness	Art. No.
	<p>Overpanel-sidelight connector</p> <p>Weight in kg: Aluminum 0.146</p>		<p>12.536</p>
	<p>PT 71 UNIVERSAL Overpanel connector with fin fitting</p> <p>Weight in kg: Aluminum 0.458 Stainless steel 0.608</p>		<p>01.161</p>
	<p>PT 80 UNIVERSAL Connector</p> <p>With the order please indicate the exact glass thickness!</p> <p>Weight in kg: Aluminum 0.555 Stainless steel 0.780</p>	<p>13 - 19 mm</p>	<p>*03.170</p> <p>03.472 not illustrated</p>
	<p>PT 81 UNIVERSAL Connector with fin fitting</p> <p>Weight in kg: Aluminum 0.784 Stainless steel 1.065</p>		<p>03.175</p>

* Suitable gaskets have to be used for systems with an 8 or 12 mm glass thickness. These are available on page 196.

	Product description	Glass thickness	Art. No.
	<p>PT 80 UNIVERSAL Connector angle 90°</p> <p>Weight in kg: Aluminum 0.467 Stainless steel 0.540</p>		03.171
	<p>PT 80 UNIVERSAL Connector, shortened, angle 90°</p> <p>Weight in kg: Aluminum 0.236 Stainless steel 0.270</p>		03.470
	<p>PT 90 UNIVERSAL Screw on fitting</p> <p>Weight in kg: Aluminum 0.120 Brass 0.160 Stainless steel 0.155</p>	13.5–19 mm	07.021
	<p>PT 91 UNIVERSAL Corner fitting</p> <p>Weight in kg: Aluminum 0.120 Brass 0.160 Stainless steel 0.155</p>	13.5–19 mm	07.023

* Suitable gaskets have to be used for systems with an 8 or 12 mm glass thickness. These are available on page 196.

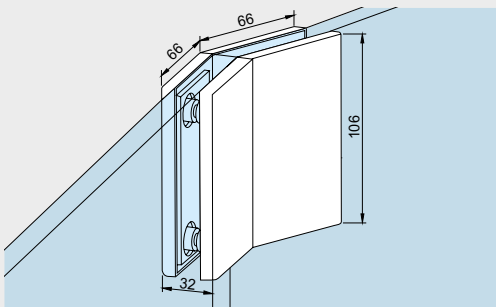
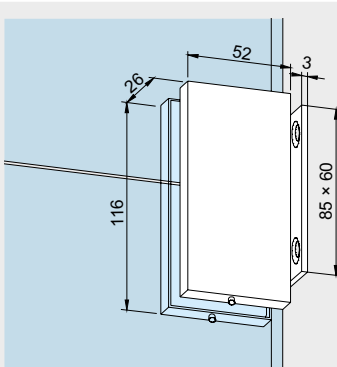
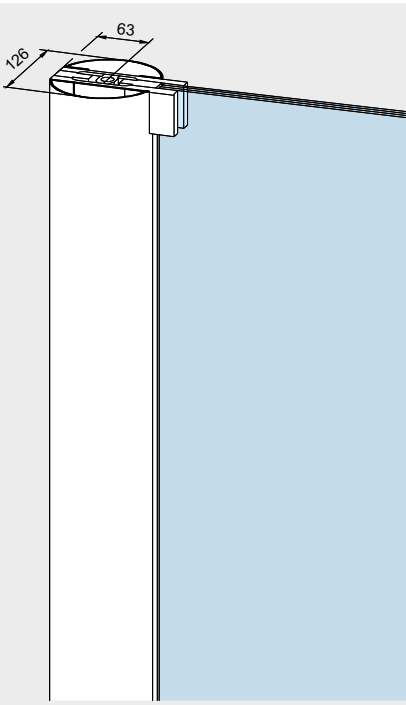
	Product description	Glass thickness	Art. No.
	<p>PT 80 UNIVERSAL Connector, angle 135°</p> <p>Weight in kg: Aluminum 0.472 Stainless steel 0.541</p>		03.172
	<p>Side connector with fixing plate</p> <p>Also suitable for 8 mm glass thickness.</p> <p>Weight in kg: Aluminum 0.313 Stainless steel 0.376</p>	10, 12 mm	01.153
	<p>Aluminum round profile for pinch free doors with 65 mm pivot point, consisting of 2 halves, prepared for UNIVERSAL fittings or door rails (76.5 mm or 100 mm).</p> <p>Please indicate:</p> <ul style="list-style-type: none"> • Panel height (max. 2,500 mm, higher dimension on request) • Required preparation of the profile for top and bottom fittings 	8 mm 12 mm	01.900 not illustrated 01.901
<p>Aluminum round profile as above, stock length 6,000 mm (unprepared)</p>			03.380
<p>Aluminum round profile, as above, stock length 3,000 mm (unprepared)</p>			03.381
<p>Aluminum round profile, as above, stock length 2,800 mm (unprepared)</p>			03.382
<p>Aluminum round profile, as above, stock length 2,800 mm (unprepared)</p> <p>Weight in kg/m: Aluminum 4.744</p>			03.383

Locks, complete for 10 mm glass thickness

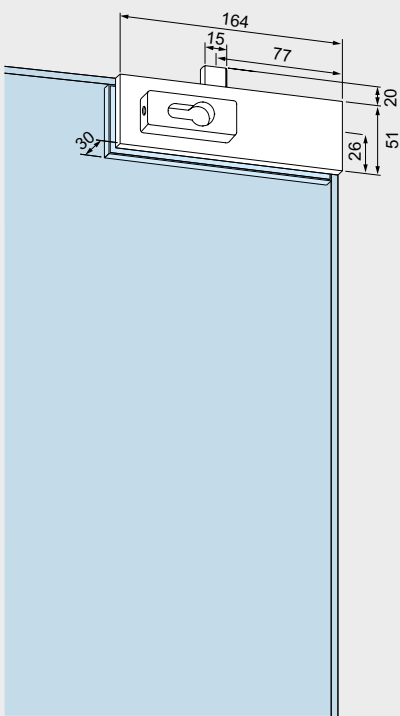
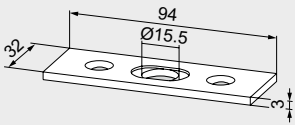
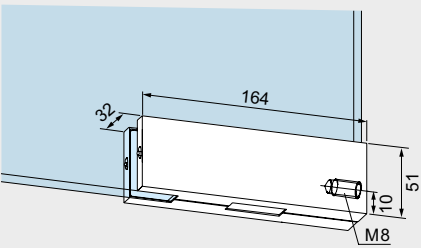
	Product description	Glass thickness	Art. No.
	<p>US 10 UNIVERSAL corner lock, prepared for Europrofile cylinder, single throw, bolt projection 20 mm, with security rosettes on both sides, 14 mm thick.</p> <p>Lock insert:</p> <ul style="list-style-type: none"> • high corrosion resistance according to EN 1670, class 4 • with regard to type-test according to DIN 18251, class 3** <p>With the order please indicate the exact glass thickness!</p> <p>prepared for KABA</p> <p>For half profile cylinder Left hand top/ right hand bottom</p> <p>Left hand bottom/right hand top</p> <p>Weight in kg: Aluminum 0.942 Brass 1.061 Stainless steel 1.053</p>	<p>10 mm 13, 15, 19 mm</p>	<p>03.206 03.285</p>
	<p>Lock keeper plate, stainless steel, two parts, adjustable ± 5 mm</p> <p>Weight in kg: 0.048</p> <p>Alternative (not illustrated): Floor sockets</p>		<p>03.340 03.288 03.287</p>
	<p>GK 30 UNIVERSAL Single overpanel strike box with threaded hole at side, to suit US 10 corner lock</p> <p>With the order please indicate the exact glass thickness!</p> <p>Weight in kg: Aluminum 0.418 Brass 0.555 Stainless steel 0.536</p> <p>GK 30 UNIVERSAL with stop</p> <p>Weight in kg: Aluminum 0.463 Stainless steel 0.597</p>	<p>13, 15, 19 mm</p>	<p>03.230 03.295 not illustrated</p> <p>*03.234/03.235 not illustrated</p>

* Left or right hand are determined by view from outside.

** Extract from DIN 18251, class 3: Type-test with 50,000 locking bolt operating cycles. Furthermore the lock was tested successfully by a neutral testing institute with 100,000 locking bolt operating cycles.

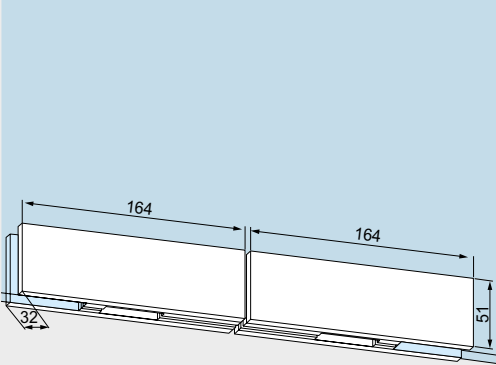
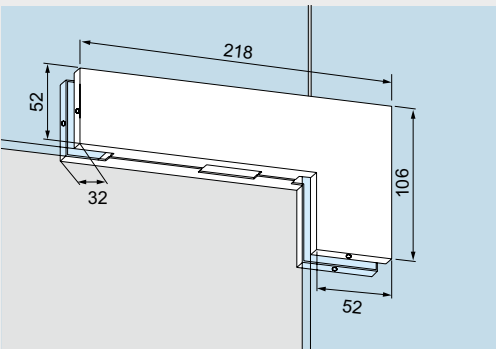
	Product description	Glass thickness	Art. No.
	<p>GK 20 UNIVERSAL Double overpanel strike box to suit US 10 corner lock, consisting of two GK 30 with threaded connecting bolt</p> <p>Weight in kg: Aluminum 0.844 Brass 1.096 Stainless steel 0.948</p> <p>GK 20 UNIVERSAL with stop</p> <p>Weight in kg: Aluminum 1.490 Brass 4.465</p> <p>Weight in kg: Aluminum 0.709 Brass 1.035 Stainless steel 1.010</p> <p>Can be used for glass thickness of up to max. 12 mm. If you wish to use thicker glasses, please get in touch with our Application Engineering department beforehand.</p>		<p>03.245</p> <p>03.247 not illustrated</p>
	<p>GK 40 UNIVERSAL Corner overpanel strike box to suit US 10 corner lock</p> <p>GK 40 UNIVERSAL with stop</p> <p>Weight in kg: Aluminum 0.754 Brass 1.035 Stainless steel 1.010</p>		<p>03.250</p> <p>*03.254/03.255 not illustrated</p>

* Order of Art. No.: left hand fin / right hand fin – determined by view from outside. (Illustration shows left hand)

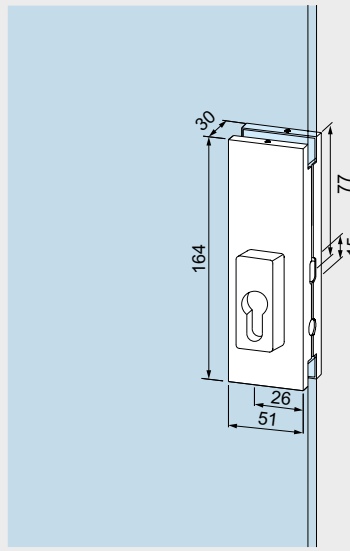
	Product description	Glass thickness	Art. No.					
	<p>US 20 UNIVERSAL Centre lock, prepared for Europrofile cylinder, single throw, bolt projection 20 mm, with security rosettes 14 mm thick.</p> <p>Lock insert:</p> <ul style="list-style-type: none"> • high corrosion resistance according to EN 1670, class 4 • with regard to type-test according to DIN 18251, class 3** 	<p>10 mm</p>	<p>03.215</p>					
	<p>With the order please indicate the exact glass thickness!</p>	<p>13, 15, 19 mm</p>	<p>03.286 not illustrated</p>					
	<p>Prepared for KABA</p>		<p>03.345</p>					
	<p>Prepared for half profile cylinder</p>		<p>*03.290/03.289</p>					
	<p>Weight in kg:</p> <table border="0"> <tr> <td>Aluminum</td> <td>0.942</td> </tr> <tr> <td>Brass</td> <td>1.061</td> </tr> <tr> <td>Stainless steel</td> <td>1.053</td> </tr> </table>	Aluminum	0.942	Brass	1.061	Stainless steel	1.053	
Aluminum	0.942							
Brass	1.061							
Stainless steel	1.053							

* Left or right hand are determined by view from outside. (illustration shows left hand)
 ** Extract from DIN 18251, class 3: Type-test with 50,000 locking bolt operating cycles. Furthermore the lock was tested successfully by a neutral testing institute with 100,000 locking bolt operating cycles.

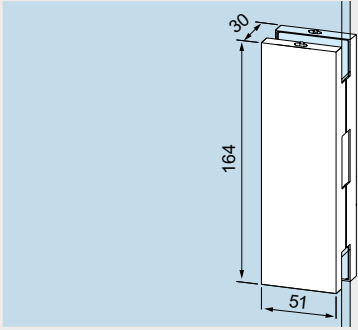
	Product description	Glass thickness	Art. No.					
	GK 50 UNIVERSAL Strike box to suit US 20 centre lock	10 mm	03.224					
	<p>With the order please indicate the exact glass thickness!</p> <p>Weight in kg:</p> <table border="0"> <tr> <td>Aluminum</td> <td>0.602</td> </tr> <tr> <td>Brass</td> <td>0.730</td> </tr> <tr> <td>Stainless steel</td> <td>0.727</td> </tr> </table>	Aluminum	0.602	Brass	0.730	Stainless steel	0.727	13, 15, 19 mm
Aluminum	0.602							
Brass	0.730							
Stainless steel	0.727							

Glass preparation fittings

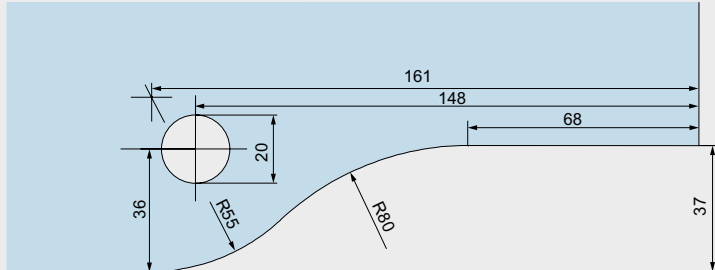
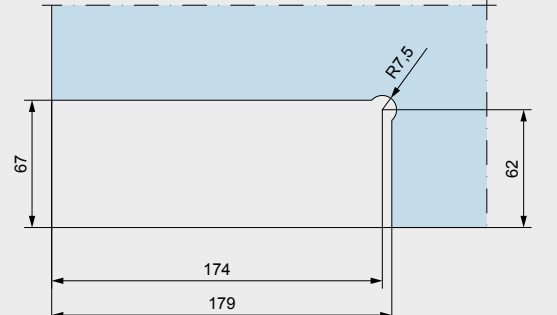
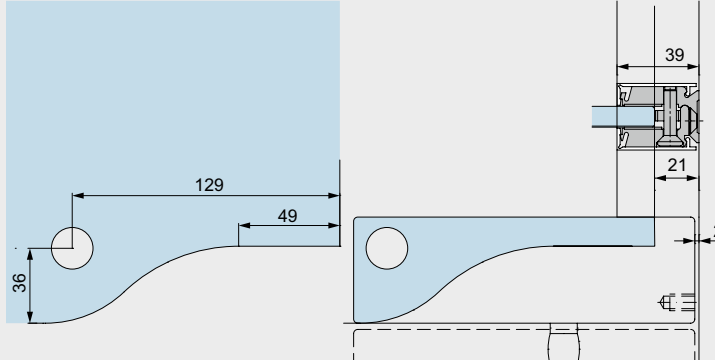
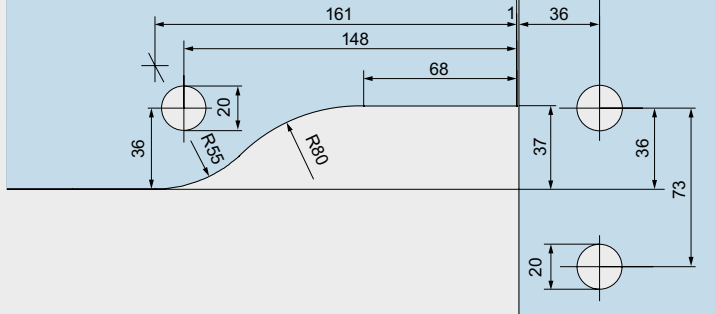
	Product description	Art. No.
	<p>PT 10, PT 20, PT 22, PT 29, PT 30 Top and bottom patches, overpanel patch</p> <p>Scale 1 : 2</p>	<p>03.100 03.110 03.114 03.120 03.212 03.280 03.281 03.282 03.420 03.421</p>
	<p>Glass preparation UNIVERSAL Motion</p>	
	<p>PT 30 Installation PT 30 with wall connection profile</p>	
	<p>PT 40 Patch for overpanel and sidelight</p> <p>Scale 1 : 2</p>	<p>03.140 03.283 03.440 03.441</p>

Product description

Art. No.

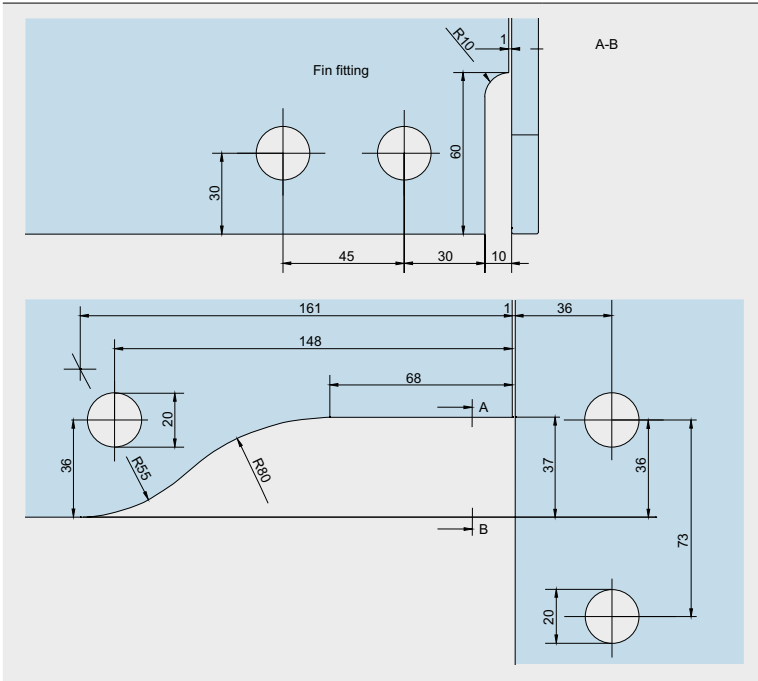

PT 41

Patch for overpanel and
sidelight with fin fitting inside

03.162

03.163

Scale 1 : 2

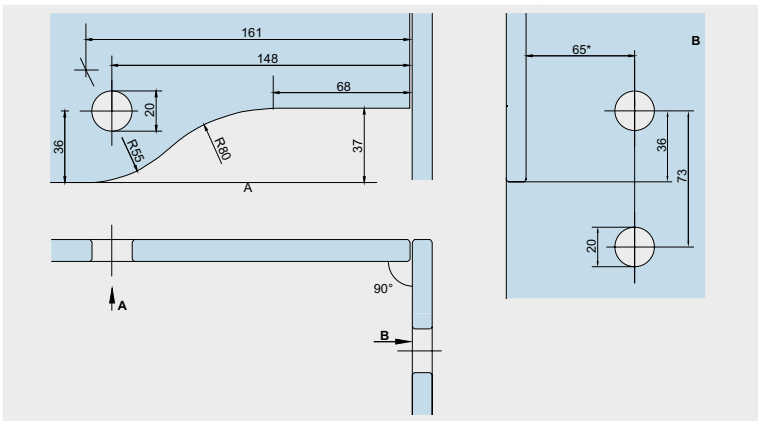

PT 42, GK 42

Angled connector 90°

03.164

03.165

Scale 1 : 2

	Product description	Art. No.
	<p>PT 51 Overpanel fin fitting for back to back doors</p> <p>Scale 1 : 2.5</p>	<p>03.160</p>
	<p>PT 60/61, PT 62 Winkelverbindung Connectors for overpanels and sidelights</p> <p>Scale 1 : 2</p>	<p>03.150 03.173</p>
	<p>PT 70 Overpanel connector</p> <p>Scale 1 : 2</p>	<p>01.150 01.158</p>

Product description

Art. No.

PT 71
Overpanel connector
with fin fitting

01.161

Scale 1 : 2

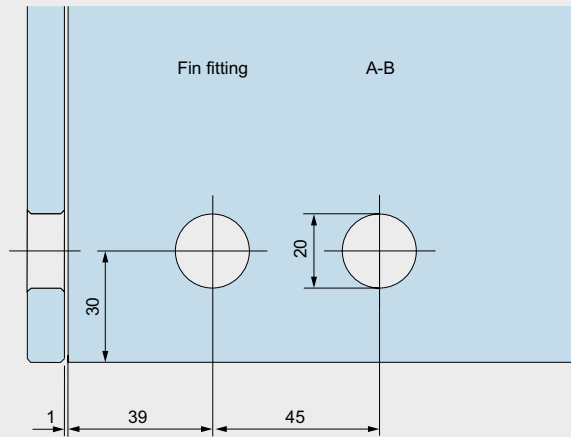
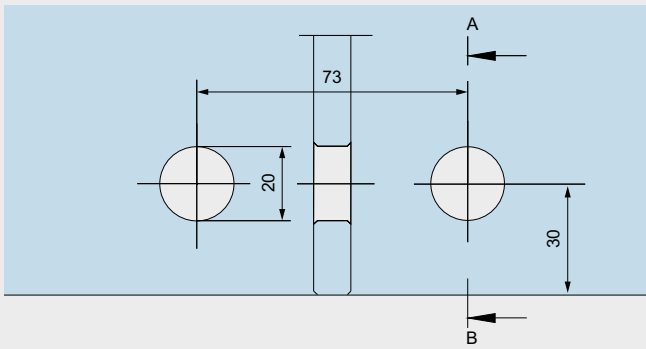

Product description

Art. No.

Overpanel-sidelight connector

12.536

Weight in kg:
Aluminum 0.146

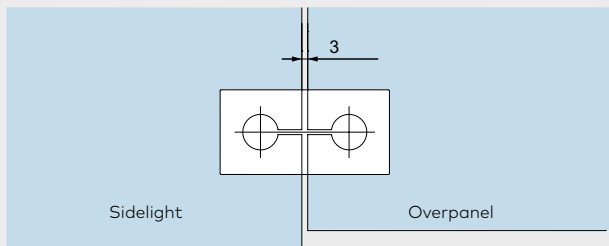
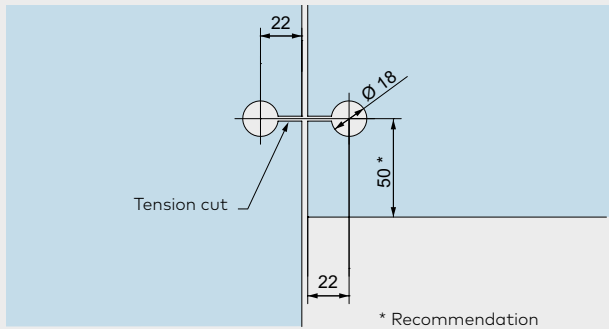

PT 80
Connector

03.170
03.472

Scale 1 : 2

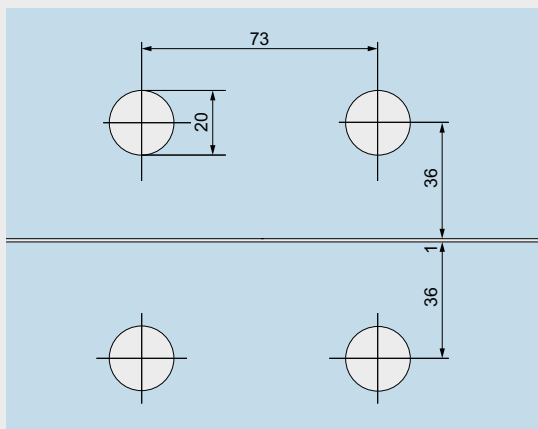

PT 81
Connector with fin fitting

03.175

Scale 1 : 2

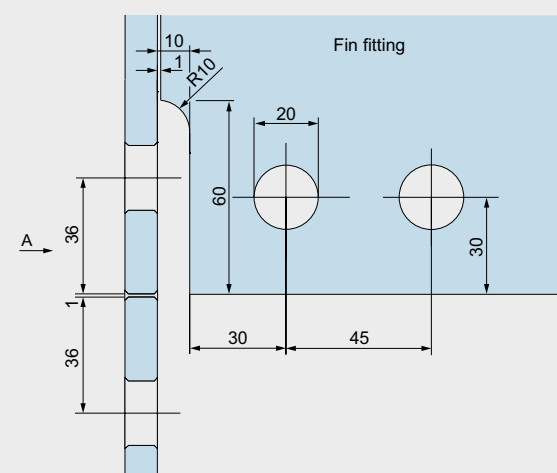

Product description

Art. No.

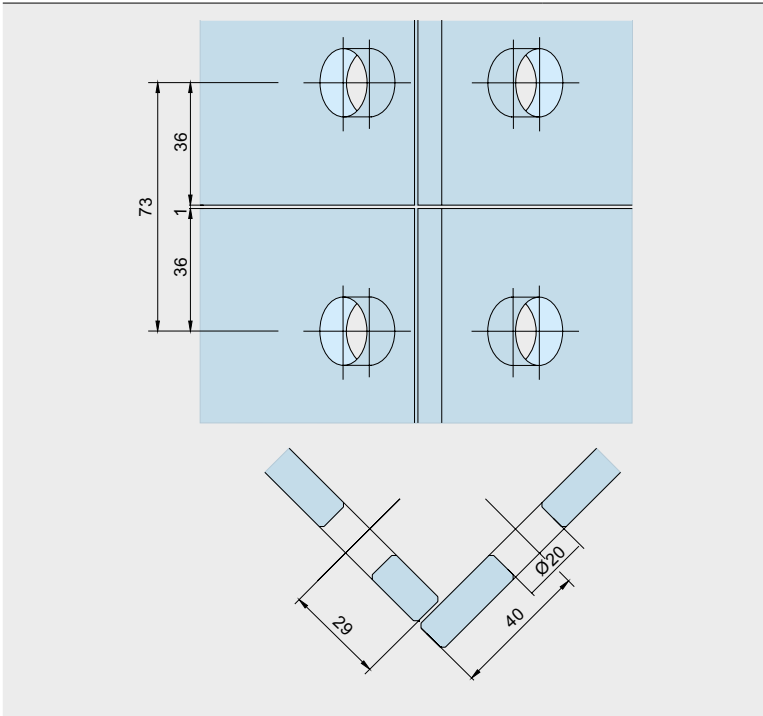

PT 80
Angled connector, 90°

03.171

Scale 1 : 2

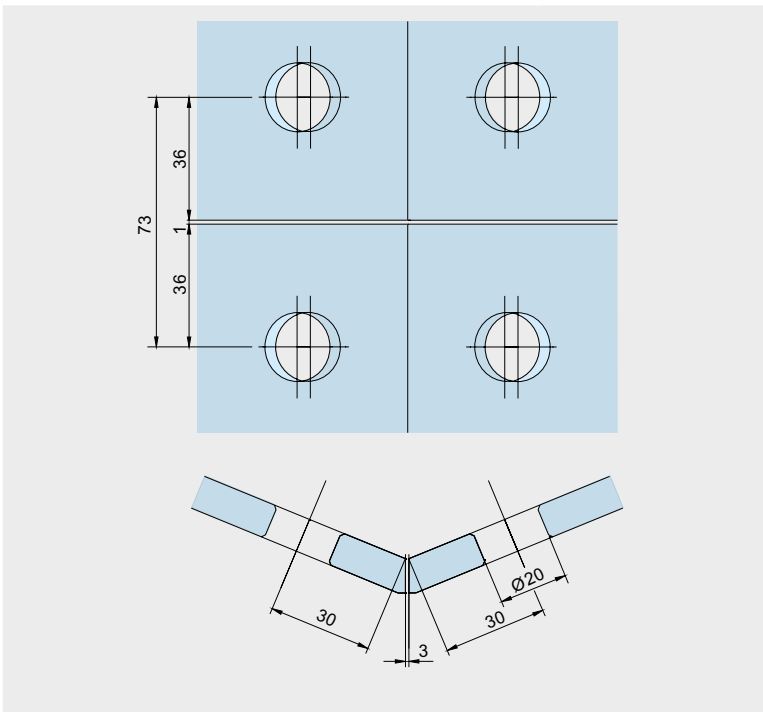

PT 80
Angled connector, 135°

03.172

Scale 1 : 2

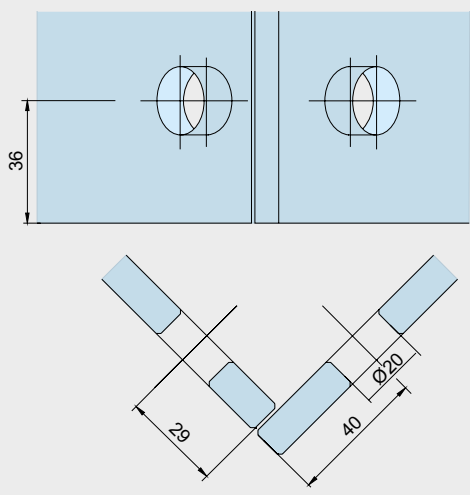
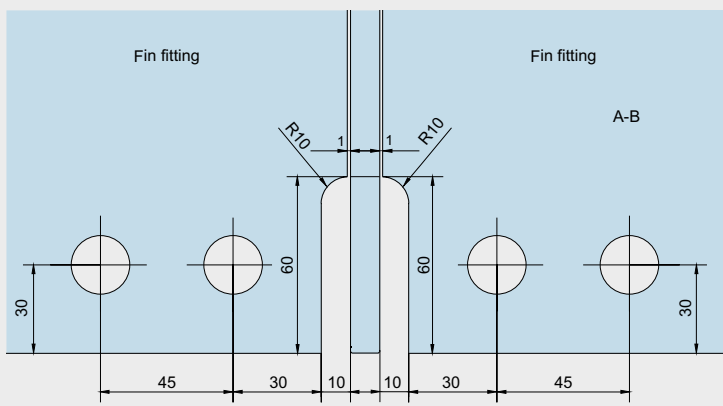
	Product description	Art. No.
	<p>PT 80 shortened Angled connector, 90° shortened</p> <p>Glass preparation examples for angles between 91° – 134° / 136° – 179° available on request.</p> <p>Scale 1 : 2</p>	<p>03.470</p>
	<p>PT 41, GK 41 Patch for overpanel and sidelight with fin fitting on both sides</p> <p>Scale 1 : 2</p>	<p>03.161</p>

	Product description	Art. No.
	<p>PT 90 Screw on fitting</p> <p>Scale 1 : 2</p>	<p>07.021</p>
	<p>PT 91 Corner fitting</p> <p>Scale 1 : 2</p>	<p>07.023</p>
	<p>Sidelight connector with fixing plate</p> <p>Scale 1 : 2</p>	<p>01.153</p>

Glass preparation locks

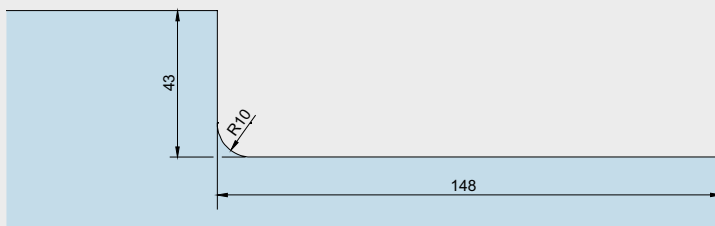
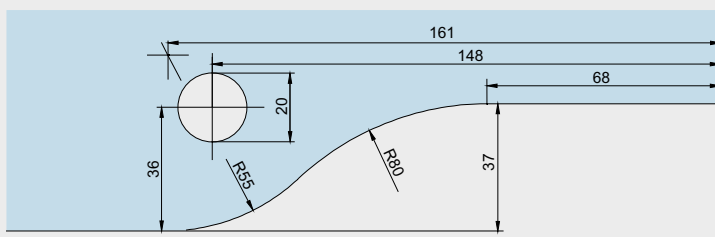
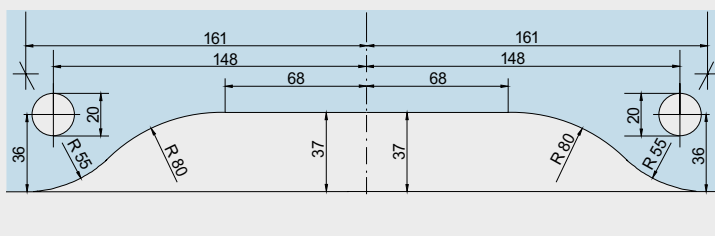
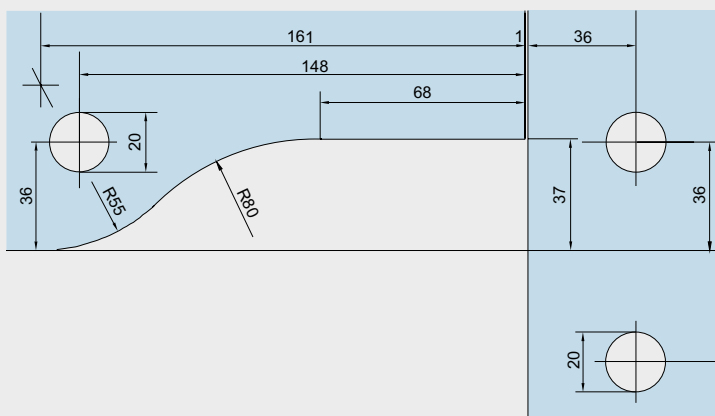
	Product description	Art. No.
	<p>US 10 Corner locks</p> <p>Scale 1 : 2</p>	<p>03.206 03.285 03.287 03.288 03.340</p>
	<p>GK 30 (PT 30) Single overpanel strike box</p> <p>Scale 1 : 2</p>	<p>03.230 03.234 03.235</p>
	<p>GK 20 Double overpanel strike box</p> <p>Scale 1 : 2</p>	<p>03.245 03.247</p>
	<p>GK 40 (PT 40) Corner overpanel strike box</p> <p>Scale 1 : 2</p>	<p>03.250</p>

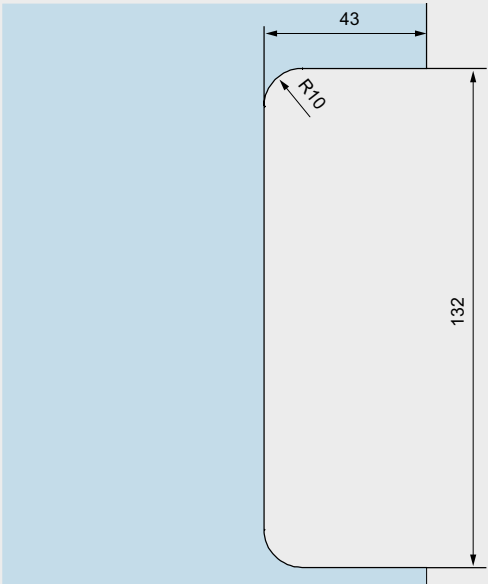
	Product description	Art. No.
	US 20. GK 50 Centre lock	03.215 03.345 03.289 03.290
	and strike box to suit centre locks	03.224
	Scale 1 : 2	

Installation details

Advisory: Please note that the upper pivots for UNIVERSAL and those for MUNDUS are not mutually compatible. The spigot diameters of the MUNDUS fittings vary..

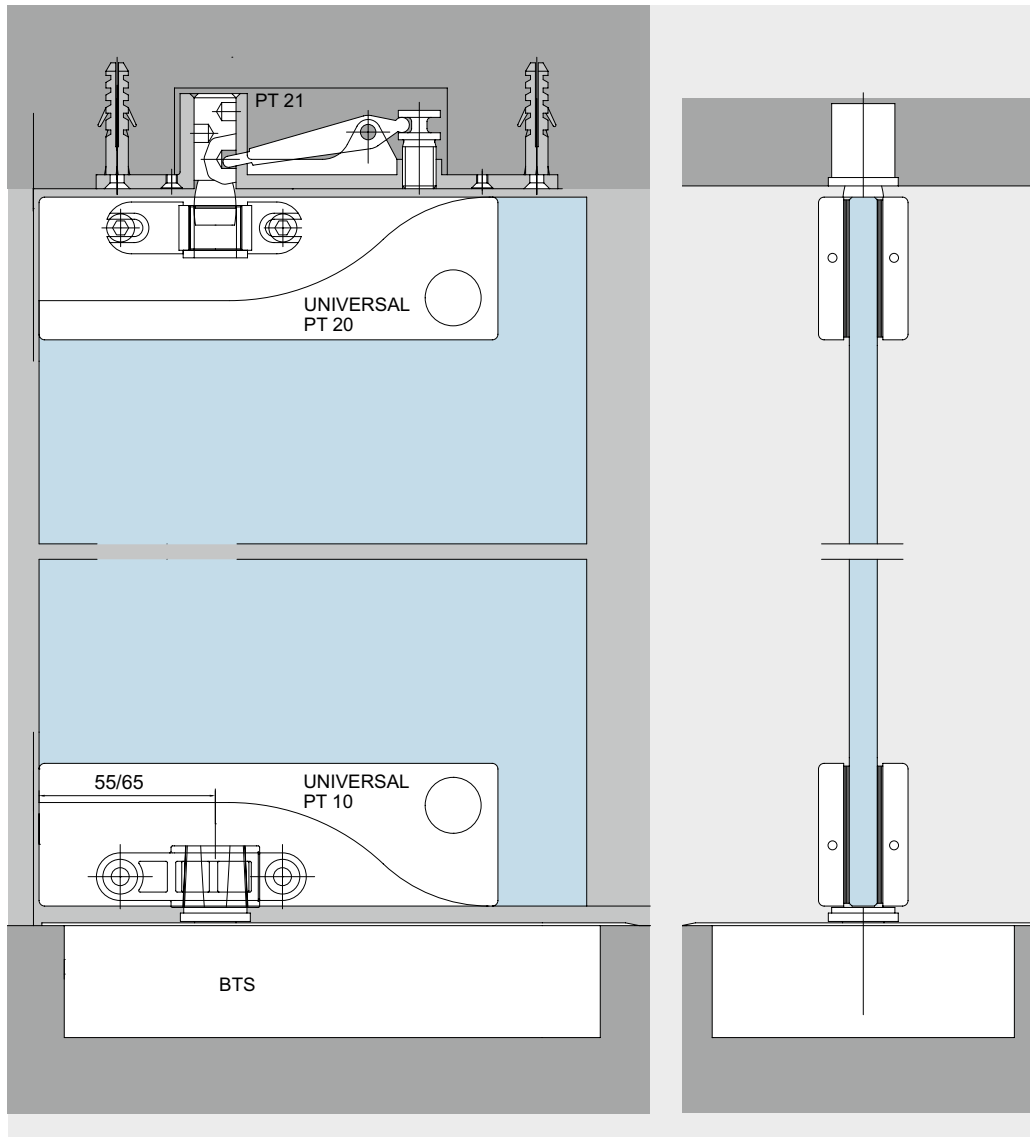
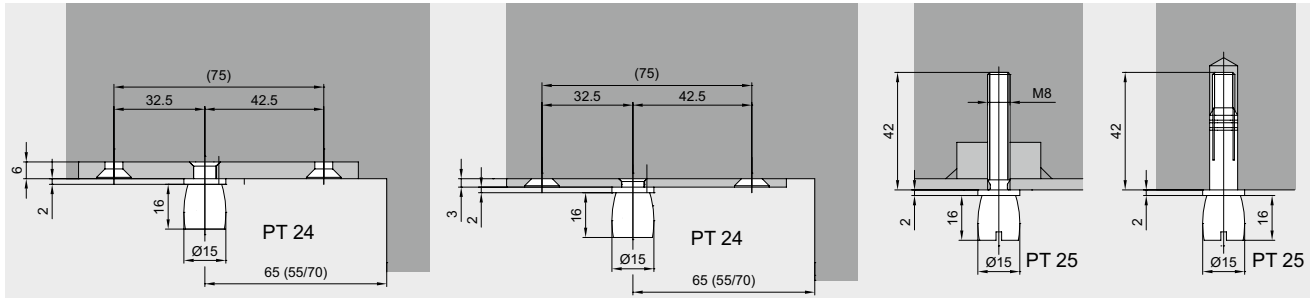

Fixing of top pivots and top centres for PT 20.

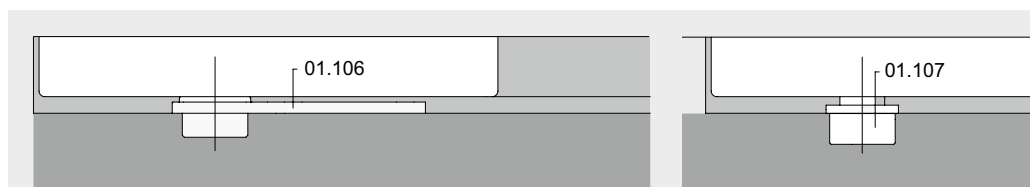

Fixing of floor springs, pivot bearings for PT 10.

Space for your notes

Content

RP

74	General information
75	Type illustrations
76	Components
188	Accessories
212	Safety-related information



RP

Marvellously concealed transom door closer

The RP pivot door system works with a tubular transom profile in which the RTS transom closer is integrated and concealed. The system is fixed on the ceiling using brackets which are concealed after system installation. A top patch fitting (UNIVERSAL PT 22) attaches the all-glass door to the closer. A bottom patch fitting (UNIVERSAL PT 10) connects the door to the floor pivot, which measures only a few centimetres. So glass thicknesses of 8 – 12 mm are feasible.

The UNIVERSAL patch fittings can be replaced by door rails top and bottom or MUNDUS patch fittings as a special option. When using MUNDUS Premium patch fittings, you also have the option of installing laminated safety glass (LSG).

The RTS transom closer not only returns the door to the zero position each time it is opened, it also has a special dampening system to protect the door against unwanted impact caused by over-aggressive opening. In addition, the integral hold-open, which also comes as standard, enables the door to be held open at an angle of 90°.

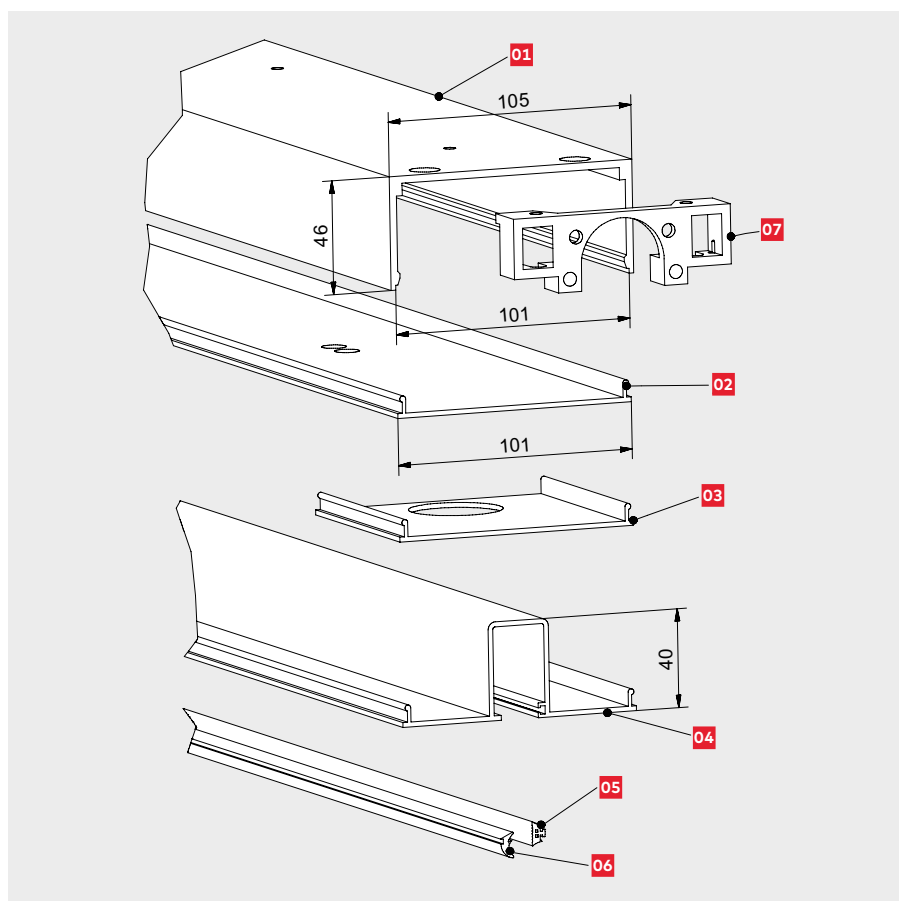

Transom tube configuration:

- 01**
Transom tube for fixing on ceiling, as lintel or similar, max. length 6,000 mm
- 02**
Cover profile for door, clip-on, max. length 6,000 mm
- 03**
Cover profile for fixed sidelights, clip-on type with glass groove
- 04**
Cover profile for fixed sidelights, clip-on, with glazing groove
- 05 / 06**
Contact profile / glass wedge profile, depending on combination for 8, 10 or 12 mm glass thicknesses of the sidelight
- 07**
Fixing bracket for securing transom tube and closer

Type selection

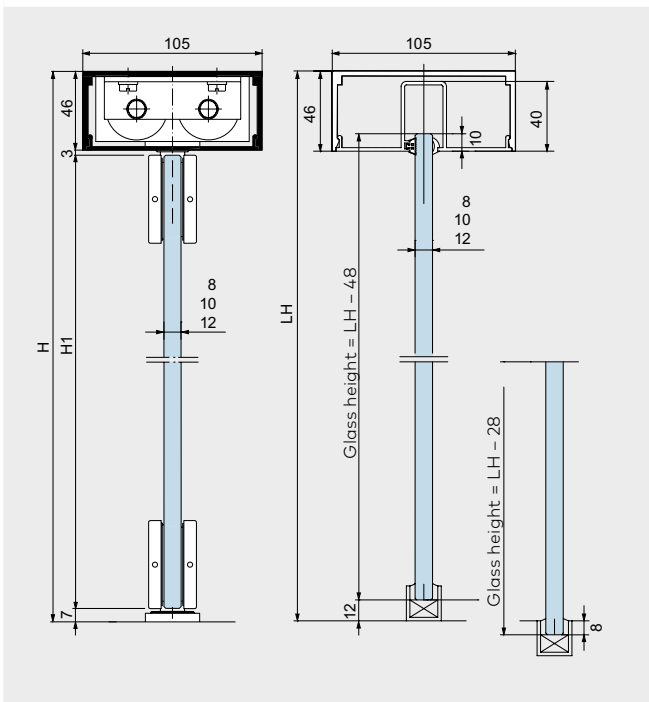
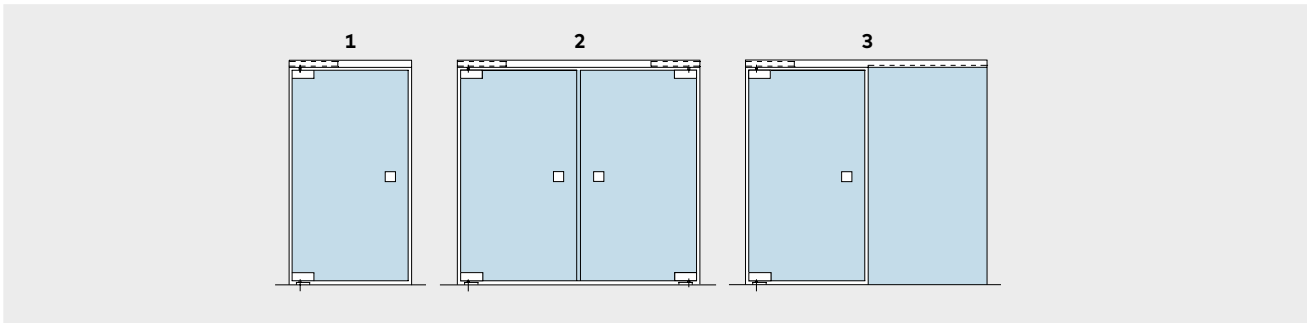

Options

- 1** Single leaf double-action door with transom tube
- 2** Pair of double-action doors with transom tube
- 3** Double-action door with through-running transom tube and fixed sidelight

Further versions up to 6000 mm are possible.

Materials and finishes

- Aluminum, silver EV1 anodized (similar Eloxal I EV1 / Eloxal II C 0) (101)
- Aluminum, similar satin stainless steel anodized (for profile material) (similar Eloxal II C 31) (113)
- Aluminum, traffic white powder coated (300)
- Aluminum special color anodized (199)
- Aluminum, special color powder coated (399)

Door panel dimensions

- Glass thicknesses: 8 / 10 / 12 mm
- Door height H1: H - 56 mm
- For max. door panel weights and widths please see the table below.

Sidelight dimensions

- Glass thickness: 8 / 10 / 12 mm with two-part sealing profile
- Sidelight height: H - 28 mm + floor pocket, where required

Also with door rails available

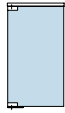
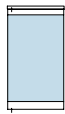
max. height	max. width	max. door weight (incl. fittings)	RTS version	
2,500	800-1,100	80 kg	RTS EN 3	
3,500	max. 1,250	110 kg	RTS EN 4	

with door rails top and bottom see detail sheets 04-030 and 04-060

If you have any questions regarding special designs with door rails or MUNDUS patch fittings, our Application Engineering department will be glad to advise you.

Double-action system for glass doors

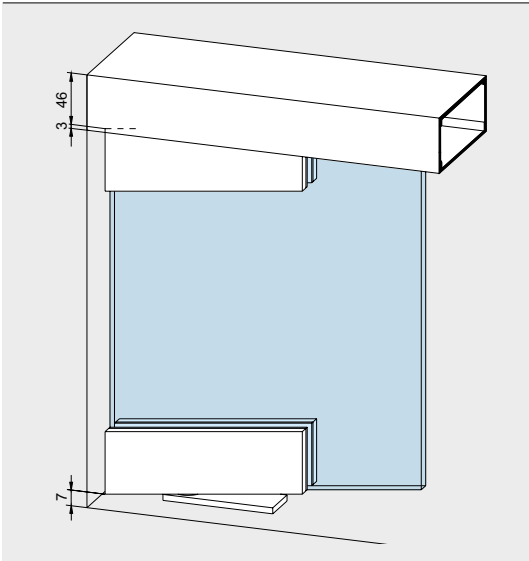
	Product description	Art. No.
	<p>Double-action system for glass doors complete, consisting of 1 transom tube length 1,000 mm; 1 cover profile length 1,000 mm; 1 RTS 85 transom closer; EN3, hold open 90° (For door widths less than 800 mm, door closers of spring strength EN 2 may also be used. Please indicate requirement when ordering.) 1 fixing bracket; 1 bottom patch fitting PT 10; 1 top patch fitting PT 22; 1 floor pivot bearing</p> <p>Weight in kg: 8.083</p> <p>When ordering, please indicate the precise system dimensions or attach a corresponding drawing.</p>	<p>01.300</p>

	Product description	Art. No.
	<p>01 Transom tube for fixing at ceiling, as lintel, or similar,</p>	
	<p>stock length 6,000 mm in fixed lengths</p>	<p>01.301 01.311</p>
	<p>Weight in kg/m: Aluminum 1.620</p>	
	<p>02 Cover profile for door area, clip-on</p>	
	<p>stock length 6,000 mm in fixed lengths</p>	<p>01.302 01.305</p>
	<p>Weight in kg/m: Aluminum 0.610</p>	
	<p>03 Cover plate with cut-out for door closer spindle</p>	
<p>length 90 mm</p>	<p>01.303</p>	
<p>Weight in kg: Aluminum 0.056</p>		
<p>04 Cover profile with glass groove to clip on Art.No. 01.301 / 311, to hold fixed sidelights inclusive</p>		
<p>05 / 06 Contact profile or glass wedge profile in 2 resp. 4 mm thicknesses, depending on combination for 8, 10 or 12 mm glass thickness of the sidelight</p>		
<p>stock length 6,000 mm in fixed lengths</p>	<p>01.304 01.314</p>	
<p>Weight in kg: Aluminum 0.810</p>		
<p>07 Fixing bracket for securing transom tube and closer</p>	<p>01.306</p>	
<p>Weight in kg: Aluminum 0.080</p>		

Content

BEYOND

80	General information
82	Type illustrations / sets
86	Components
86	Glass preparation
188	Accessories
212	Safety-related information



BEYOND

Systematic design

Safe, functional and extremely attractive, BEYOND, the unique system for glass doors without risk of pinched fingers with swing doors.

The development of BEYOND has been shaped by the search for a solution that combines a modern, attractive design with maximum safety and stability. In the swing-door system the pivot point is located directly at the glass edge, thus preventing the risk of trapped fingers often found at the secondary closing edges of glass swing.

BEYOND opens up a huge range of opportunities for incorporating frameless glass doors into toughened glass assemblies and wall openings. The BEYOND system offers an elegant, sophisticated solution for swing doors in all situations, whether private or public, modern or traditional.

Developed with the practical requirements of the market in mind, this product offers a sensible alternative wherever security, safety and functionality need to be complemented with an attractive design.



Safe and secure

The patented BEYOND swing door system with its pivot point located centrally in the glass axis and close to the glass edge ensures safety and security. The alternative options of elegant, continuous pivot rod or smart short rod make the system suitable for any room situation. And with a choice of pull handles or lock/lever handle combinations, BEYOND enables the realisation of your design ideas.



The over panel pivot fitting
– a slim connector.



An option for the bottom pivot point – short rod on a floor pivot.

If floor pivot bearings are being used, a separate lock or a tumbler is required.

Short pivot rod

The BEYOND swing door system with short pivot rod offers maximum flexibility. No matter what the door dimensions, BEYOND short fittings provide a versatile solution.

dormakaba floor pivots, or – particularly for double-action doors – dormakaba BTS floor springs, form the ideal base for ensuring that the door always returns safely and securely to its home position. Since with the BTS floor spring the position of the pivot point requires it to be buried under the adjacent wall, the use of a glass side panel is recommended in this case. The top connection depends on the type of unit. When incorporating the glass door into a toughened glass assembly, the top connection is formed by an over panel fitting; in the case of doors in wall openings, a top pivot bearing is fitted to the ceiling or in the lintel.

Load transfer from the overpanel and side panel can be effected by means of wall adapter profiles.

Depending on customer requirements, BEYOND offers suitable fittings for 10 mm and 12 mm glass. Finishes for fittings and accessories: aluminum EV1-Deco anodized (114) or similar satin stainless steel anodized (107).

For maximum values please see the typical assemblies.

Note:

Overpanel fitting wall connector
max. 1,200 mm door width;
overpanel fitting glass connector
max. 1,000 mm door width.

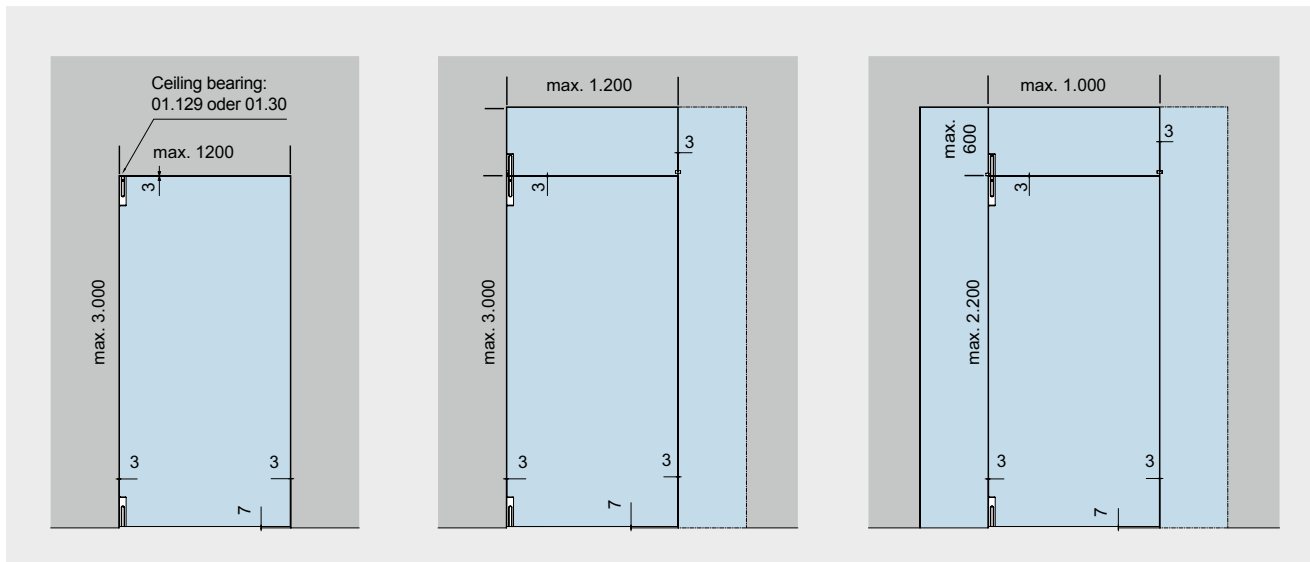

Basic set for individual door.
For installation in masonry.
Optionally with side panel on closing side.

Max door height 3,000 mm
Max door weight 80 kg

Basic set and over panel fitting wall connector for door with over panel.
Optionally with side panel on closing side.

Max door height 3,000 mm
Max door weight 80 kg

Basic set and over panel fitting wall connector for door with over panel and side panel on pivot point side.
Optionally with side panel on closing side.

Max door height 2,200 mm
Max door weight 80 kg

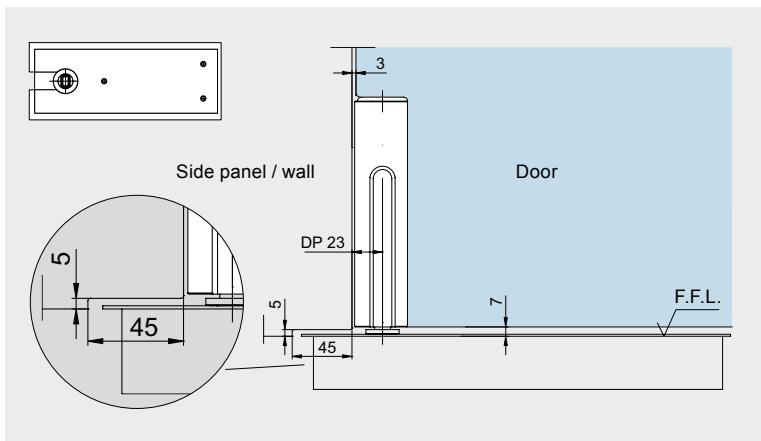

Combination BEYOND and BTS

(door closer available from Door Control Division)
With the BTS floor spring, the position of the pivot point means that the unit has to be buried under the adjacent wall, or that the glass side screen has to be appropriately machined (see adjacent detail). The height of the recess cut into the glass will need to be adapted to the installation situation and the means by which the side screen is fixed.

Fittings and glass connector

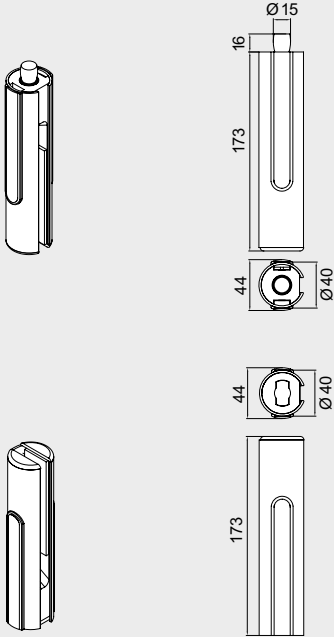
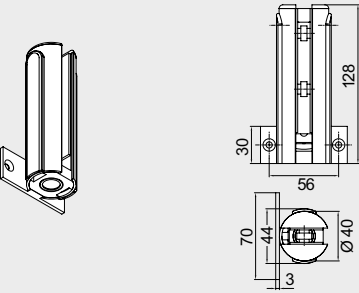
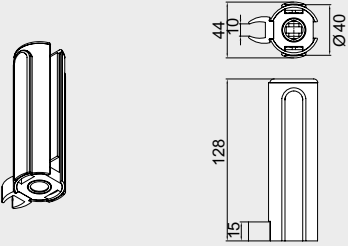
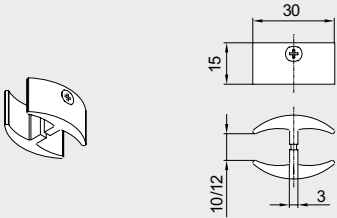
	Product description	Glass thickness	Art. No.
	<p>BEYOND basic set: Pivoting fitting set, short type, comprising</p> <ul style="list-style-type: none"> • 1 top pivot fitting with pivot Ø 15 mm, • 1 bottom pivot fitting with insert for floor spring spindle (90° turnable, e. g. BTS 80) or round pivot 	<p>10 mm 12 mm</p>	<p>30.100 30.101</p>
	<p>BEYOND overpanel fitting, wall connector, with plastic socket for top pivot</p>	<p>10 mm 12 mm</p>	<p>30.120 30.121</p>
	<p>BEYOND overpanel fitting, glass connector, with plastic socket for top pivot</p>	<p>10 mm 12 mm</p>	<p>30.130 30.131</p>
	<p>BEYOND glass connector, plastic, black, for connection of side panel at closing side</p>	<p>10 mm and 12 mm</p>	<p>30.320</p>

Continuous pivot rod

The BEYOND swing door system with continuous rod offers complete freedom from the risk of trapped fingers. By locating the pivot point of the swing door right at the glass edge and providing a round profile, the nip hazard is reduced to zero.

For the floor mounting of single-action, and particularly double-action doors, the dormakaba BTS floor spring offers a convenient alternative to the dormakaba floor pivot. Since with the BTS floor spring the position of the pivot point requires it to be buried under the adjacent wall, the use of a glass side panel is recommended in this case. As with the short-rod model, the top connection depends on the type of unit. Toughened glass assemblies are fitted with an over panel pivot fitting, whereas with doors in wall openings a top pivot bearing with ceiling fixing is used. Load transfer from the over panel and side panel can be effected by means of wall adapter profiles.

In the case of heights over 2,200 mm, an anti-vibration device located midway along the pivot rod ensures quiet door operation.

Depending on customer requirements, BEYOND offers suitable fittings for 10 mm and 12 mm glass.

Finishes for fittings and accessories: aluminum EV1-Deco anodized (compatible with finish 150) (114) or similar satin stainless steel anodized (107).

For maximum values please see the typical assemblies.

Note:

Overpanel fitting wall connector
max. 1,200 mm door width;
overpanel fitting glass connector
max. 1,000 mm door width.

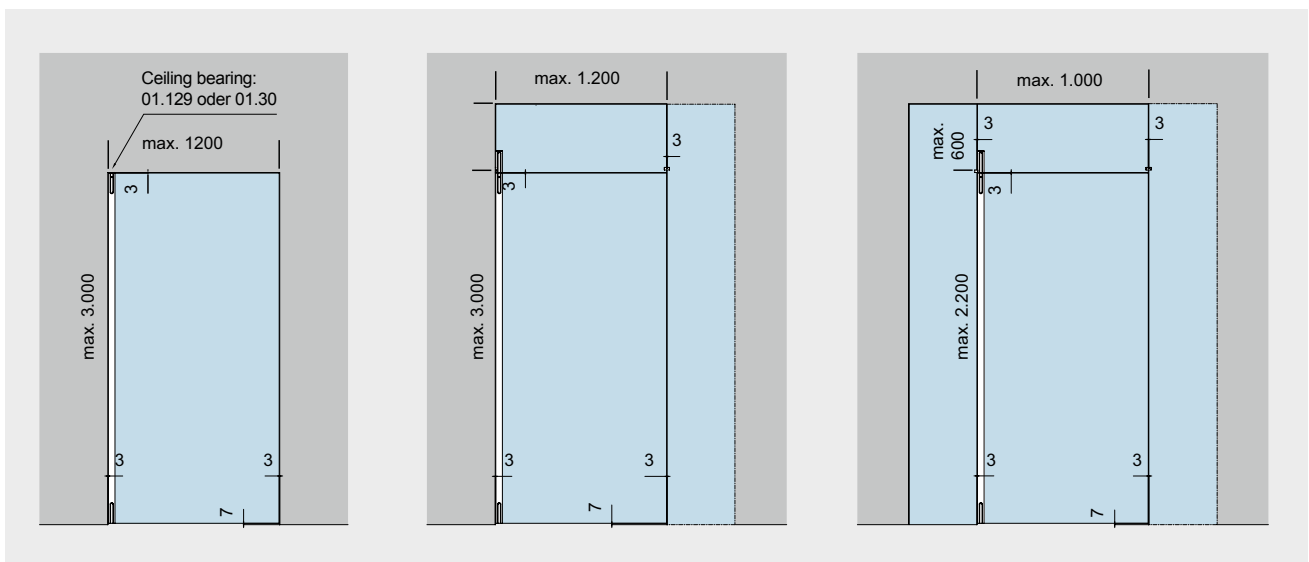

Basic fitting for individual door.
For installation in masonry.

Max door height 3,000 mm
Max. door weight 80 kg

Basic fitting and over panel fitting wall connector for door with over panel.
Optionally with side panel on closing side.

Max door height 3,000 mm
Max. door weight 80 kg

Basic fitting and over panel fitting wall connector for door with over panel and side panel on pivot point side.
Optionally with side panel on closing side.

Max door height 2,200 mm
Max. door weight 80 kg

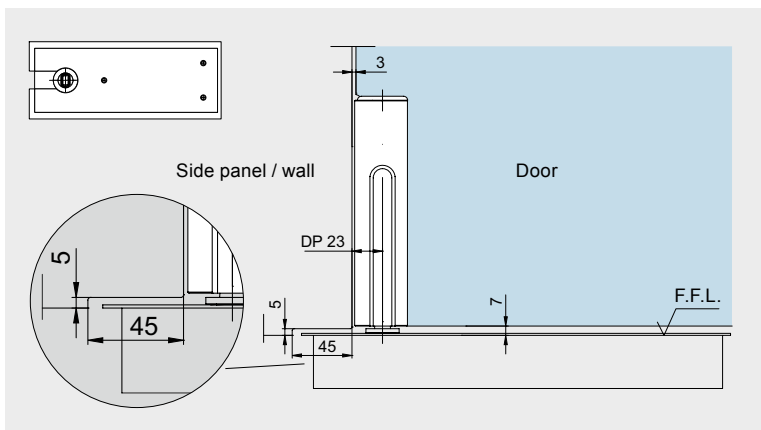

Combination BEYOND and BTS

(door closer available from Door Control Division)
With the BTS floor spring, the position of the pivot point means that the unit has to be buried under the adjacent wall, or that the glass side screen has to be appropriately machined (see adjacent detail). The height of the recess cut into the glass will need to be adapted to the installation situation and the means by which the side screen is fixed.

Fittings and glass connector

	Product description	Glass thickness	Art. No.
	<p>BEYOND basic fitting: Pivoting fitting, long type, with pivot \varnothing 15 mm at top and insert for floor spring spindle (90° turnable, e. g. BTS 80) or round pivot at bottom</p> <p>Please indicate exact door height = glass measurement with order.</p>	<p>10 mm 12 mm</p>	<p>30.110 30.111</p>
	<p>BEYOND overpanel fitting, wall connector, with plastic socket for top pivot</p>	<p>10 mm 12 mm</p>	<p>30.120 30.121</p>
	<p>BEYOND overpanel fitting, glass connector, with plastic socket for top pivot</p>	<p>10 mm 12 mm</p>	<p>30.130 30.131</p>
	<p>BEYOND glass connector, plastic, black, for connection of side panel at closing side</p>	<p>10 mm and 12 mm</p>	<p>30.320</p>
	<p>BEYOND anti-vibration device for pivot fitting, long</p>	<p>10 mm 12 mm</p>	<p>30.034 30.035</p>

Glass preparation

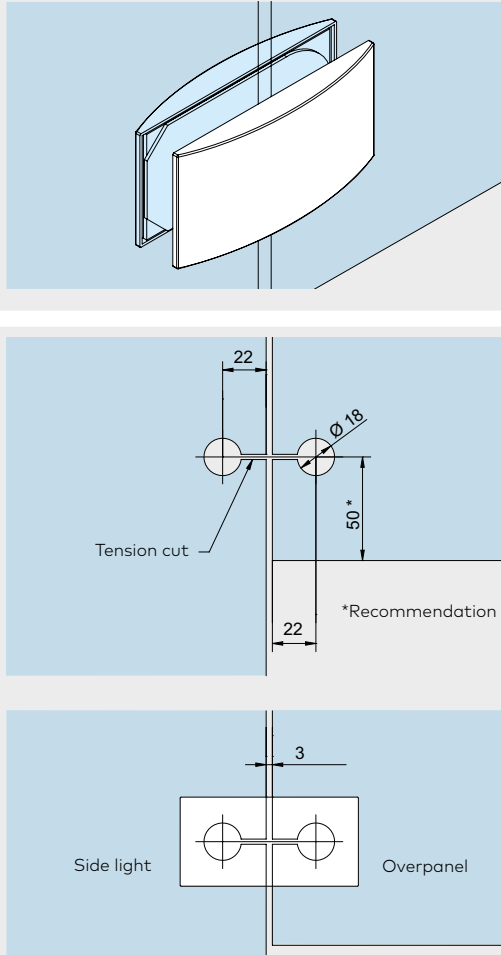
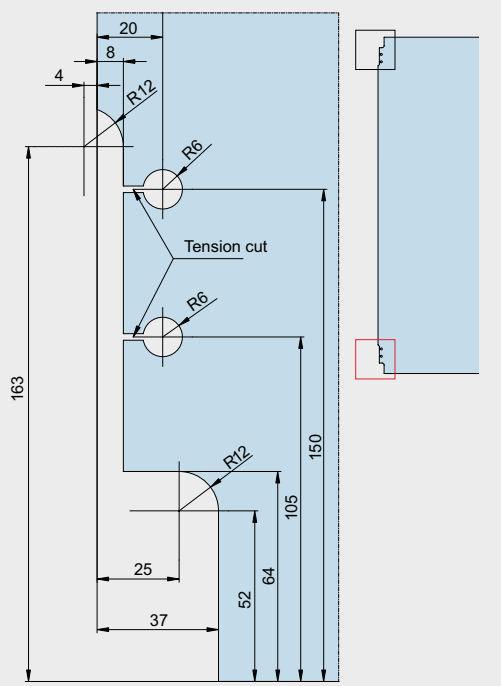
	Product description	Art. No.
	<p>Overpanel-sidelight connector</p> <p>Weight in kg: Aluminum 0.146</p>	<p>12.536</p>
	<p>Pivoting fitting set, short type</p> <p>Drawing shows the bottom glass penetration. Top edge of glass is prepared accordingly.</p>	<p>30.100 30.101</p>

Product description

Art. No.

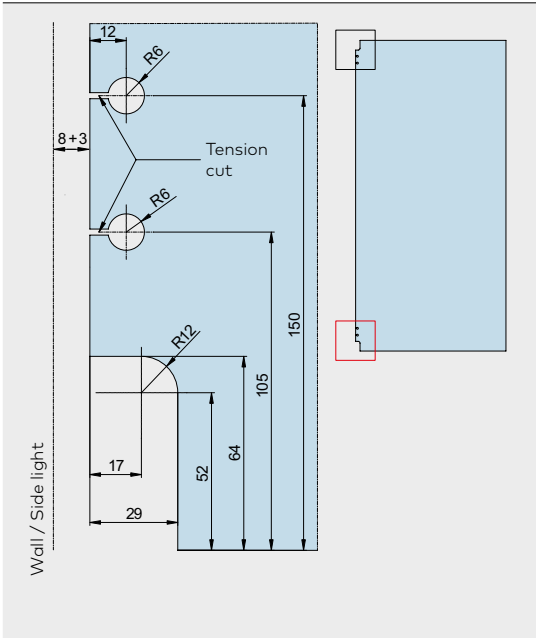

Pivoting fitting, long type

Drawing shows the bottom glass penetration.
Top edge of glass is prepared accordingly.

30.110

30.111

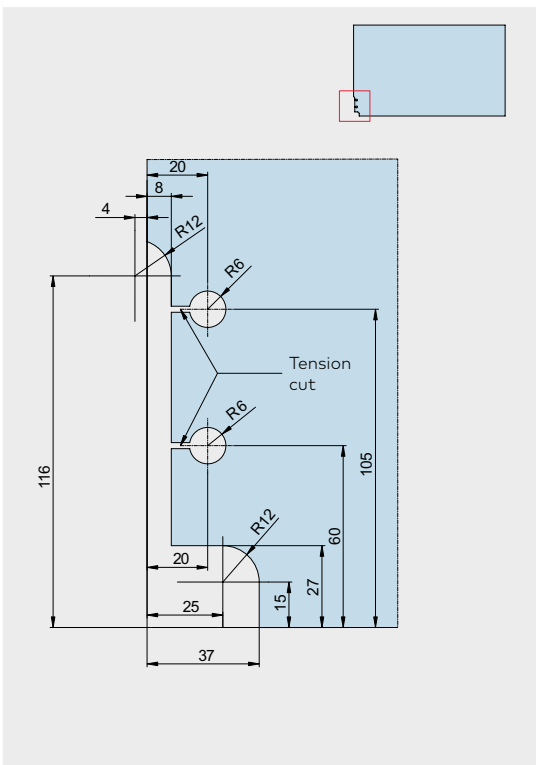

Overpanel fitting

Wall connector and
glass connector

30.120

30.121

30.130

30.131

Content

EA

90	General information
91	Type illustrations
92	Components
100	Glass preparation
188	Accessories
212	Safety-related information



EA

The expansive range with slimline bodies for offset hung doors

EA patch fittings are characterized by their slim, neat shape and skilful hinge design. This comprehensive range of fittings allows the transparent elegance of single-action doors to reach their full potential – whether hung in frames or integrated in toughened glass assemblies.

Easy glass preparation secure fixing

dormakaba has an intimate knowledge of the special properties of glass as a building material. This has led to the design of fittings requiring only minimal glass preparation – a quick and easy cut out with additional holes. Carefully considered and positive measures have been taken to create the maximum clamping surface with optimum clamping efficiency.

Suitable for 10, 12 and 8 mm glass thicknesses

dormakaba EA patch fittings are available for 10 and 12 mm glass thicknesses. With additional gaskets these fittings can also be used for 8 mm glass.

Reliability built in

Quality materials and thorough workmanship mean that EA patch fittings have the features necessary to meet the most demanding of specifications.

Matching range of locks

The EA range includes a variety of locks and strike boxes in a matching design concept, giving the designer plenty of choice from the options available.

Virtually unlimited choice of colours and finishes

EA corner patches are available in the following finishes

- Aluminum, silver EV1 anodized (similar Eloxal I EV1 / Eloxal II C 0) (101)
- Aluminum, similar satin stainless steel anodized (107)
- Aluminum special color anodized (199)
- Aluminum, special color powder coated (399)

Short delivery times

All standard articles as per price list are available ex-stock (factory). Specials will be prepared promptly.



Offset hung doors in rebated frames and toughened glass assemblies

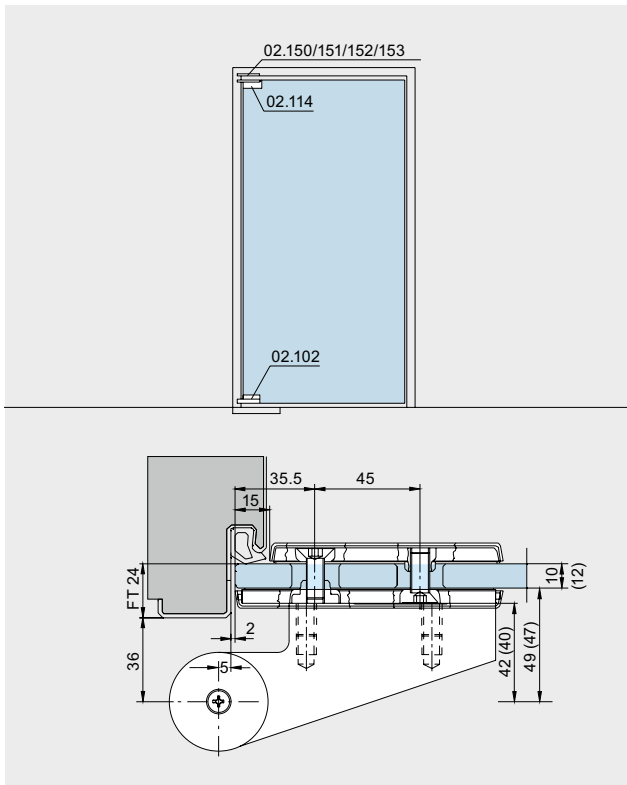

Offset hung doors in rebated frames

max. door weight: 90 kg
max. door width: 1,000 mm,
using a bottom door rail: 1,100 mm

EA patch fittings for offset hung doors in rebated frames are supplied as standard prepared for 24 mm rebate depth. They can be prepared to suit rebate depths from 15 – 23 mm, and from 25 – 40 mm. Please specify rebate depth with order.

max. door weight for 25–40 mm rebate depth: 80 kg
max. door width for 25–40 mm rebate depth: 900 mm
For doors with max. weight of 80 kg and max. width of 1,000 mm use door rails.

The top centre frame portions are prepared to suit wood and steel frames. For aluminum frames, please enquire, giving details of aluminum system.

FT = rebate depth

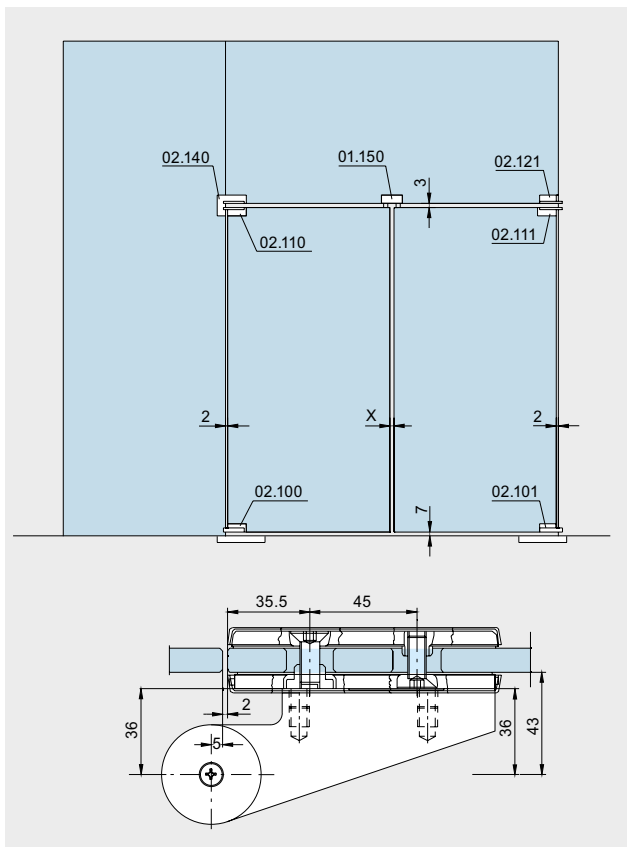

Offset hung doors in toughened glass assemblies

max. door weight: 100 kg
max. door width: 1,100 mm

For door weights up to 100 kg and widths up to 1,200 mm, door rails should be used.

EA patch fittings for offset hung doors in toughened glass assemblies have a 36 mm offset (= 43 mm from pivot point to glass surface).

Gap required between leaves on pairs of doors

Individual leaf width in mm	X = gap required in mm
400–600	8
600–1,000	6

Torque for fixing screws

Screws M 8: 12 Nm

Patch fittings for offset hung doors in rebated frames with 24 mm rebate depth

For 10 mm glass thickness (42 mm offset = 49 mm from pivot point to glass surface), complete.
 For 12 mm glass thickness (40 mm offset = 47 mm from pivot point to glass surface), complete.
 Accessories see page 188.

	Product description	Glass thickness	Art. No.
	<p>Bottom patch fitting to suit floor spring spindle, or round pivot 14 mm Ø counter-plate reduced by 15 mm to give free glass edge at side</p> <p>Weight in kg: Aluminum 0.747</p>	10 mm 12 mm	*02.102/02.103
	<p>Bottom patch fitting to suit floor spring spindle, or round pivot 14 mm Ø counter-plate reduced by 15 mm to give free glass edge at side and bottom</p> <p>Weight in kg: Aluminum 0.715</p>	10 mm 12 mm	*02.104/02.105
	<p>Top patch fitting counter-plate reduced by 15 mm to give free glass edge at side</p> <p>Weight in kg: Aluminum 0.680</p>	10 mm 12 mm	*02.112/02.113
	<p>Top patch fitting counter-plate reduced by 15 mm to give free glass edge at side and top</p> <p>Weight in kg: Aluminum 0.644</p>	10 mm 12 mm	*02.114/02.115

* Order of Art.No.: Left hand / right hand – determined by view from hanging side. (Illustration shows right hand)

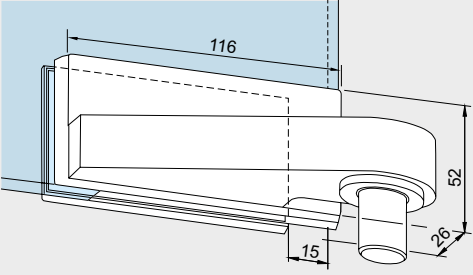
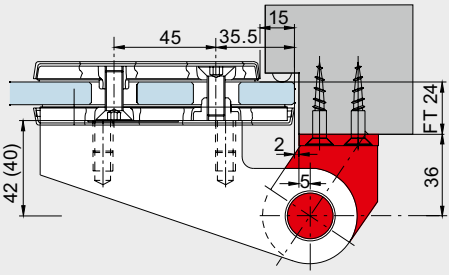
	Product description	Glass thickness	Art. No.
	<p>Overpanel patch fitting counter-plate reduced by 15 mm to give free glass edge at side, bushing outside Ø 20 mm, pivot Ø 15 mm</p> <p>Weight in kg: Aluminum 0.654</p>	<p>10 mm 12 mm</p>	<p>*02.122/02.123</p>
	<p>Top patch fitting complete with pivot for frame fixing, counter-plate reduced by 15 mm to give free glass edge at side</p> <p>Weight in kg: Aluminum 0.915</p>	<p>10 mm 12 mm</p>	<p>*02.206/02.207</p>

*Order of Art.No.: Left hand / right hand – determined by view from hanging side.
(Illustration shows right hand)

Patch fittings for offset hung doors in rebated frames with individual frame stop depth

Please specify rebate depth with order.

Rebate depth X = distance between outer surface of frame and rebate/stop (15 to 23 resp. 25 to 40 mm).
 Offset = rebate depth + 18 mm (33 to 41 resp. 43 to 58 mm). Complete, for 10 mm glass thickness.
 Accessories see page 188.

	Product description	Art. No.
	<p>Bottom patch fitting to suit floor spring spindle or round pivot 14 mm Ø, counter-plate reduced by 15 mm to give free glass edge at side</p> <p>Weight in kg: Aluminum 0.832</p>	*02.106/02.107
	<p>Bottom patch fitting to suit floor spring spindle or round pivot 14 mm Ø, counter-plate reduced by 15 mm to give free glass edge at side and bottom</p> <p>Weight in kg: Aluminum 0.800</p>	*02.108/02.109
	<p>Top patch fitting counter-plate reduced by 15 mm to give free glass edge at side</p> <p>Weight in kg: Aluminum 0.760</p>	*02.116/02.117
	<p>Top patch fitting counter-plate reduced by 15 mm to give free glass edge at side and top</p> <p>Weight in kg: Aluminum 0.728</p>	*02.118/02.119

*Order of Art.No.: Left hand / right hand – determined by view from hanging side.
 (Illustration shows right hand)

Product description

Art. No.

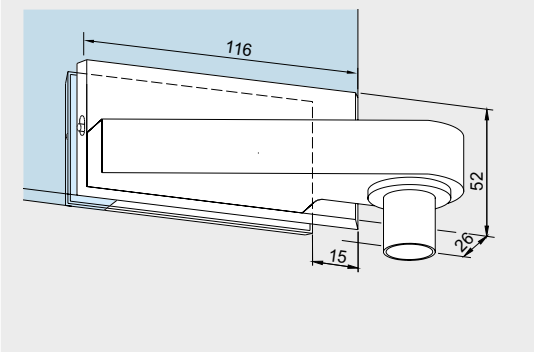
**Overpanel patch fitting**

counter-plate reduced by
15 mm to give free glass edge at side

*02.124/02.125

Weight in kg:
Aluminum 0.724

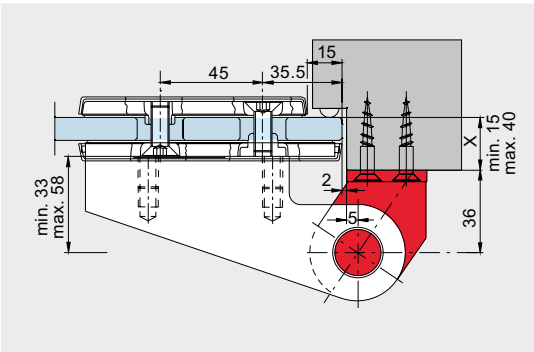
**Top patch fitting**

complete with pivot for frame fixing,
counter-plate reduced by 15 mm to give free
glass edge at side

*02.208/02.209

Weight in kg:
Aluminum 0.995

*Order of Art.No.: Left hand / right hand – determined by view from hanging side.
(Illustration shows right hand)

Patch fittings for offset hung doors in toughened glass assemblies

(36 mm offset = 43 mm from pivot point to glass surface), complete, for 10 and 12 mm glass thickness.

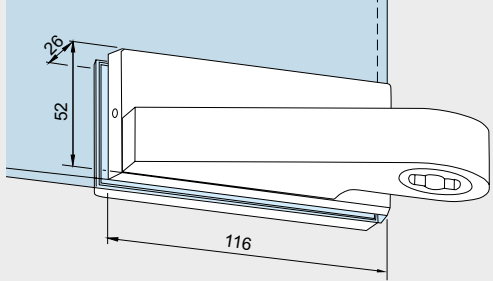
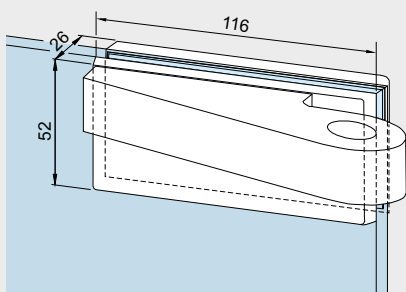
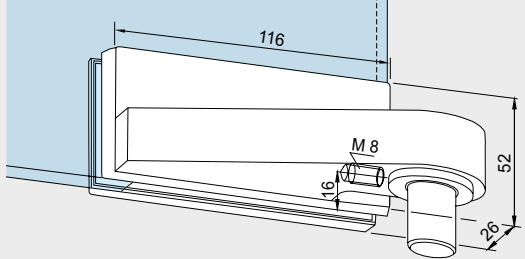
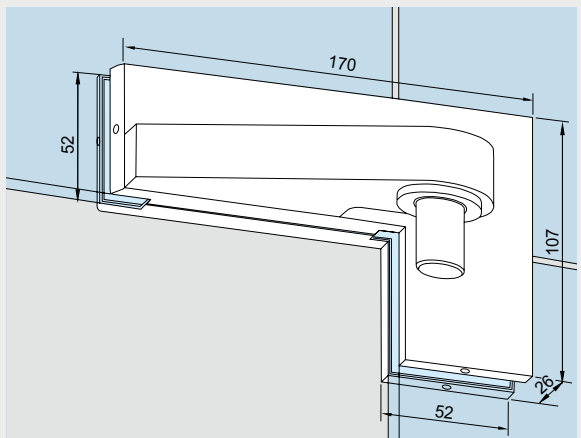
	Product description	Art. No.
	<p>Bottom patch fitting to suit floor spring spindle, or round pivot 14 mm Ø</p> <p>Weight in kg: Aluminum 0.730</p>	<p>*02.100/02.101</p>
	<p>Top patch fitting</p> <p>Weight in kg: Aluminum 0.660</p>	<p>*02.110/02.111</p>
	<p>Overpanel patch fitting bushing outside Ø 20 mm, pivot Ø 15 mm</p> <p>Weight in kg: Aluminum 0.637</p>	<p>*02.120/02.121</p>
	<p>Patch fitting for overpanel and sidelight bushing outside Ø 20 mm, pivot Ø 15 mm</p> <p>Weight in kg: Aluminum 0.832</p>	<p>*02.140/02.141</p>

* Order of Art.No.: Left hand / right hand – determined by view from hanging side. (Illustration shows right hand)

Product description

Art. No.

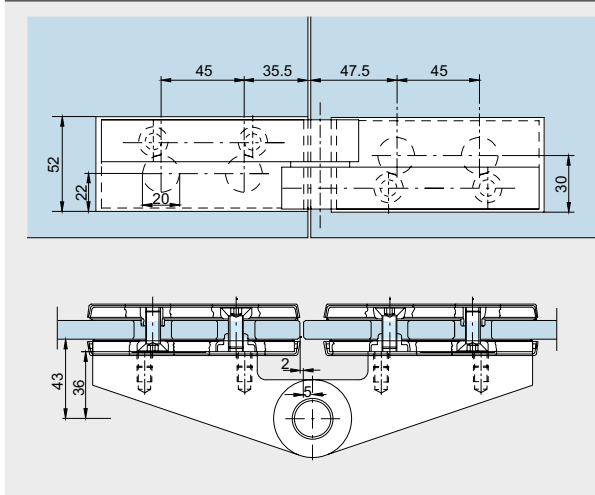
**Top patch fitting**

complete with pivot for sidelight

***02.200/02.201**

Weight in kg:
Aluminum 1.415

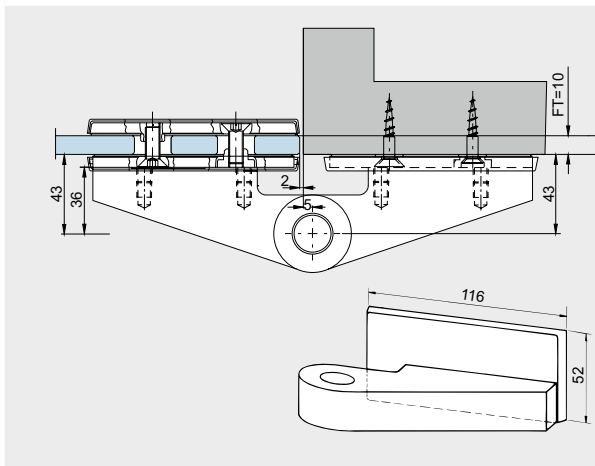
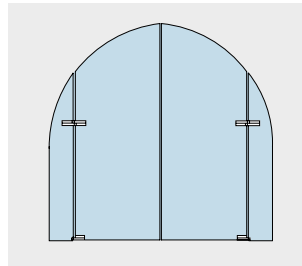
**Top patch fitting**

complete with pivot for wall fixing

***02.202/02.203**

Weight in kg:
Aluminum 1.277

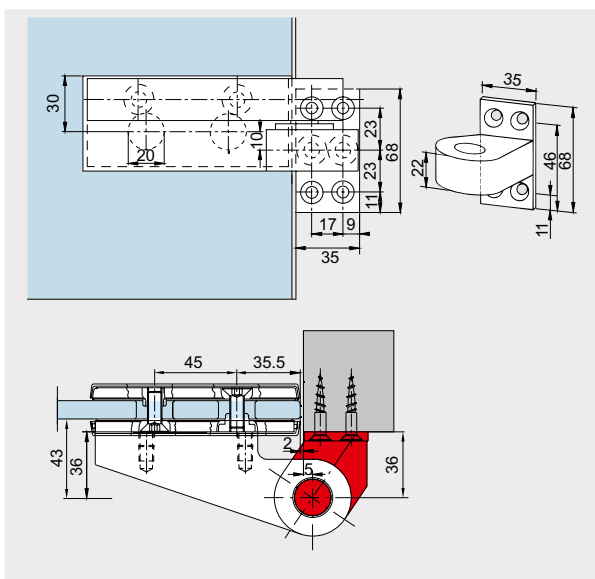
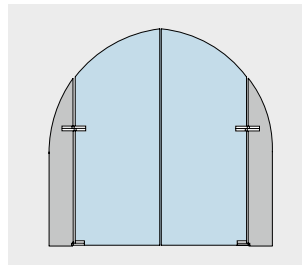
**Top patch fitting**

complete with pivot for frame fixing

***02.204/02.205**

Weight in kg:
Aluminum 0.895

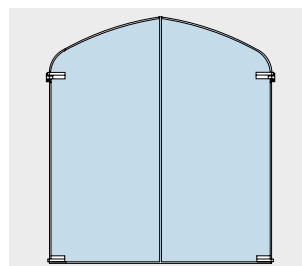

* Order of Art.No.: Left hand / right hand – determined by view from hanging side. (Illustration shows right hand)

Top centres for wood and steel frames

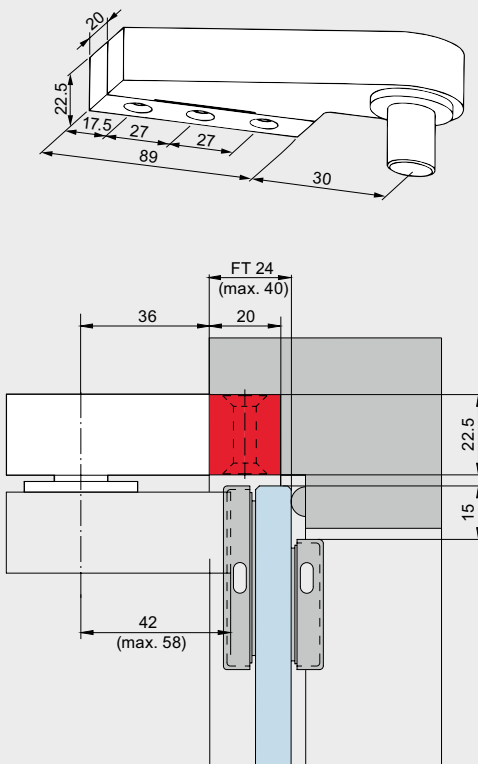
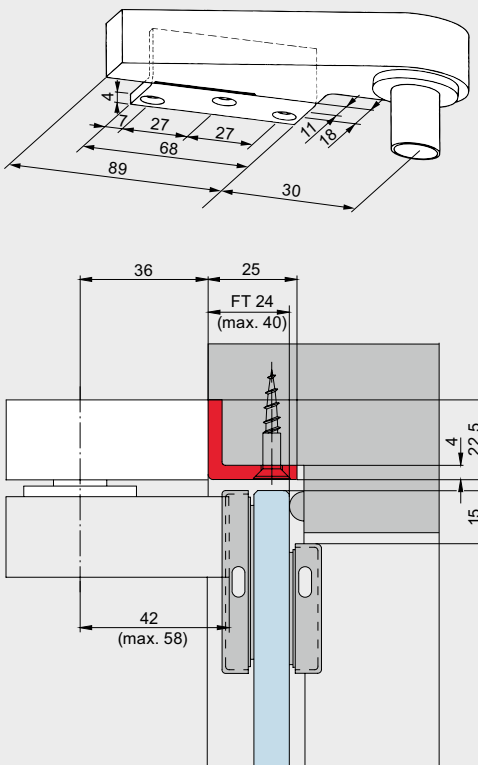
	Product description	Art. No.
	<p>Frame top centre with fixing block</p> <p>Weight in kg: Aluminum 0.471</p> <p>(If corner fittings / door rails are combined with frame top centres as described, please indicate rebate depth with order.)</p>	<p>02.150</p>
	<p>Frame top centre with angle bracket</p> <p>Weight in kg: Aluminum 0.453</p>	<p>02.151</p>

	Product description	Art. No.
	<p>Frame top centre only for steel frames, with special wedge screw fixing</p> <p>Weight in kg: Aluminum 0.390</p> <p>Drill jig:</p>	<p>*02.152/02.153</p> <p>8.02.081.001.50</p>
	<p>Frame top centre AT 212 GSR with mounting plate</p> <p>Weight in kg: Stainless steel 0.215</p>	<p>*02.340/02.341</p>

*Order of Art.No.: Left hand / right hand – determined by view from hanging side. (Illustration shows right hand)

Glass preparation

	Product description	Art. No.
	Bottom patch fittings	left 02.100 02.102 02.104 02.106 02.108
		right 02.101 02.103 02.105 02.107 02.109
Scale 1 : 2		
	Top patch fittings	left 02.110 02.112 02.114 02.116 02.118
		right 02.111 02.113 02.115 02.117 02.119
Scale 1 : 2		
	Overpanel patch fittings	left 02.120 02.122
		right 02.121 02.123
Scale 1 : 2		
	Patch fittings for overpanel and sidelight	left 02.140
		right 02.141
Scale 1 : 2		

Space for your notes

Content

TP/TA

104	General information
105	Type illustrations
108	Components
188	Accessories
212	Safety-related information



TP/TA

TP/TA – door rails which leave nothing to be desired

TP / TA door and side panel rail coordinate in design, dimensions and finishes with all dormakaba patch fittings. This creates the opportunity to specify fittings for the assembly which provide maximum protection and effective sealing of the lower glass edges. The provision of door rails allows the installation of extremely heavy-duty and wide doors.

Tamper resistant, with integral locks

The robust base rails are screwed together from alternate sides of the door at 150 mm centres. This makes unauthorised removal of the rail virtually impossible. All door rails are available with integral locks, prepared for profile cylinders and with security rosettes, or prepared for certain lever locks.

Special security- and quality characteristics

The particular feature of the locks with bottom or top locking bolt is a special corrosion and abrasion resistant bolt with integrated safety roll pin (hardened). By this the locks comply to DIN 18251, class 3 (according to type testing*) and the highest corrosion resistance according to EN 1670, class 4 is achieved. Furthermore the lock was tested successfully by a neutral testing institute with 500,000 latch and 100,000 locking bolt operating cycles.

Easy door adjustment – especially whilst hanging

Because TP / TA rails are a screw/clamp system, they have a great advantage over other systems. The rail can be adjusted up and down, and also side to side, to compensate for irregularities in the door opening. Also, the clip-on rail cover has advantages. Because the door can be hung and secured without it, the covers need not be fixed until the wet trades have finished and the cleaners have been through.



No glass preparation, firm fixing

dormakaba has an intimate knowledge of the special properties of glass as a building material. This has led to the design of rails requiring no glass preparation – no holes, no cut-outs. Carefully considered and positive measures have been taken to create the maximum clamping surface with optimum clamping efficiency.

Two heights, length to order, to suit 10 mm or 8 mm and 12 mm

glass thickness – further glass thicknesses and versions for bullet-proof glass on request
All TP / TA door rails are available in 100 mm (4") or 76.5 mm (3") heights, and in lengths to your order. They are supplied as standard for 10 mm glass thickness; but with replacement gasket they will suit 12 mm or 8 mm glass thicknesses. On request the door rails of 100 mm height can also be realised for 13.5/15/17/19 and 21 mm glass thicknesses (for toughened, laminated glass) and versions for bullet-proof glass 13.5 – 30 mm glass thicknesses.

Variable pivot point and absolute pinch free on door rails for centre hung doors TP

All the inserts for door rails in the TP / TA range have been designed and manufactured to give two options in the pivot point distance from the sidepanel or frame. It can be either 55 mm or 65 mm (distance from pivot point to door edge – 53 mm and 63 mm respectively). In order to change from the standard dimension of 65 mm to 55 mm, the standard insert is unscrewed from the patch, rotated through 180°, and refixed in position. At 65 mm pivot point and the use of a special round profile (page 124) doors can be built pinch free (constant air gap of 4 mm).

Reliability built in

Quality materials and thorough workmanship mean that TP / TA rails have the features necessary to meet the most demanding of specifications.

Short delivery times

All standard articles as per price list are available ex-stock (factory). Specials will be prepared promptly.

Finishes

Special coatings are required at extreme environment conditions (i.e. coastal areas).

*Extract from DIN 18251, class 3: type-test with 50,000 locking bolt operating cycles.

Technical specifications

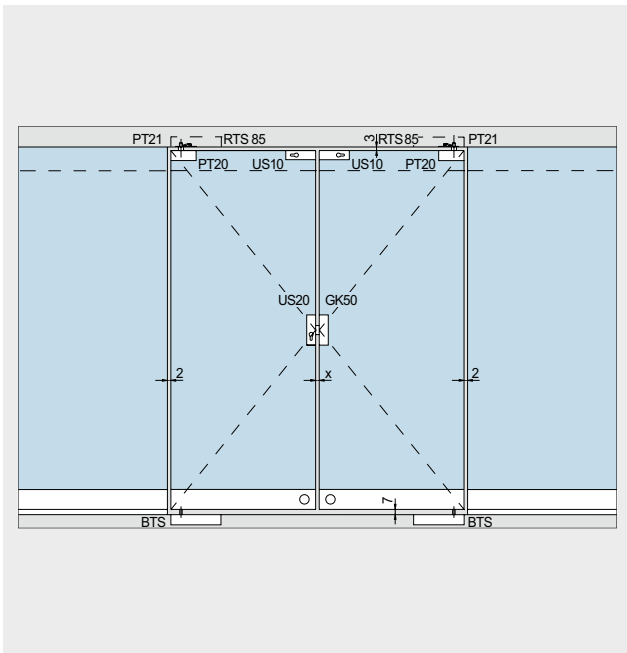

Glass size – height:

Rail height – 100 mm		Rail height – 76.5 mm	
Use of rail(s)	total door height less	Use of rail(s)	total door height less
bottom	75.0 mm	bottom	56.5 mm
top	75.0 mm	top	56.5 mm
bottom + top	150.0 mm	bottom + top	113.0 mm

Please treat floor and ceiling clearances separately

Gap required between pairs of doors:

Offset hung doors:

Individual leaf width	X
over 1,000 mm	4 mm
1,000–600 mm	6 mm
600–400 mm	8 mm

Centre hung doors:

X = 4 mm

RTS = transom closer

Maximum dimensions for use of bottom door rails in combination with top door rails or top patch fittings

	Panel type	Bottom door rail standard			Bottom door rail special type with bottom strap in forged steel			Comments
		weight kg	width mm	height mm	weight kg	width mm	height mm	
Door rails for centre hung doors, combined with...								
... Patch fittings UNIVERSAL	●	110	1,200	3,000	120	1,200	3,500	*For high frequented doors we generally recommend to use the bottom strap in forged steel with reduced max. measurements. **pivot point 15/18 mm ***only for double-action doors with door rail top and bottom
... Patch fittings EP UNIVERSAL pinch	●	100	1,100	3,000				
... Door rails standard	●	120	1,200	3,500	150*** (120*)	1,400*** (1,200*)	4,000 (3,500*)	
Door rails for offset hung doors in toughened glass assemblies, combined with...								34 mm door stap for toughened glass assemblies
... Patch fittings EA	●	100	1,200	3,000				40 mm/42 mm door stap for 24 mm/26 mm rebate depth
... Door rails standard	●	100	1,200	3,500				
Door rails for offset hung doors in rebated frames (24 mm/26 mm rebate depth), combined with ...								43 mm/58 mm door stap for 27 mm–40 mm rebate depth
... Patch fittings EA	●	90	1,100	3,000				
... Door rails standard	●	90	1,100	3,500				
Door rails for offset hung doors in rebated frames (27 mm – 40 mm rebate depth), combined with ...								43 mm/58 mm door stap for 27 mm–40 mm rebate depth
... Patch fittings EA	●	80	1,000	3,000				
... Door rails standard	●	80	1,000	3,500				

Torque for fixing screws: Screws M 8 : 20 Nm

Rail cross sections

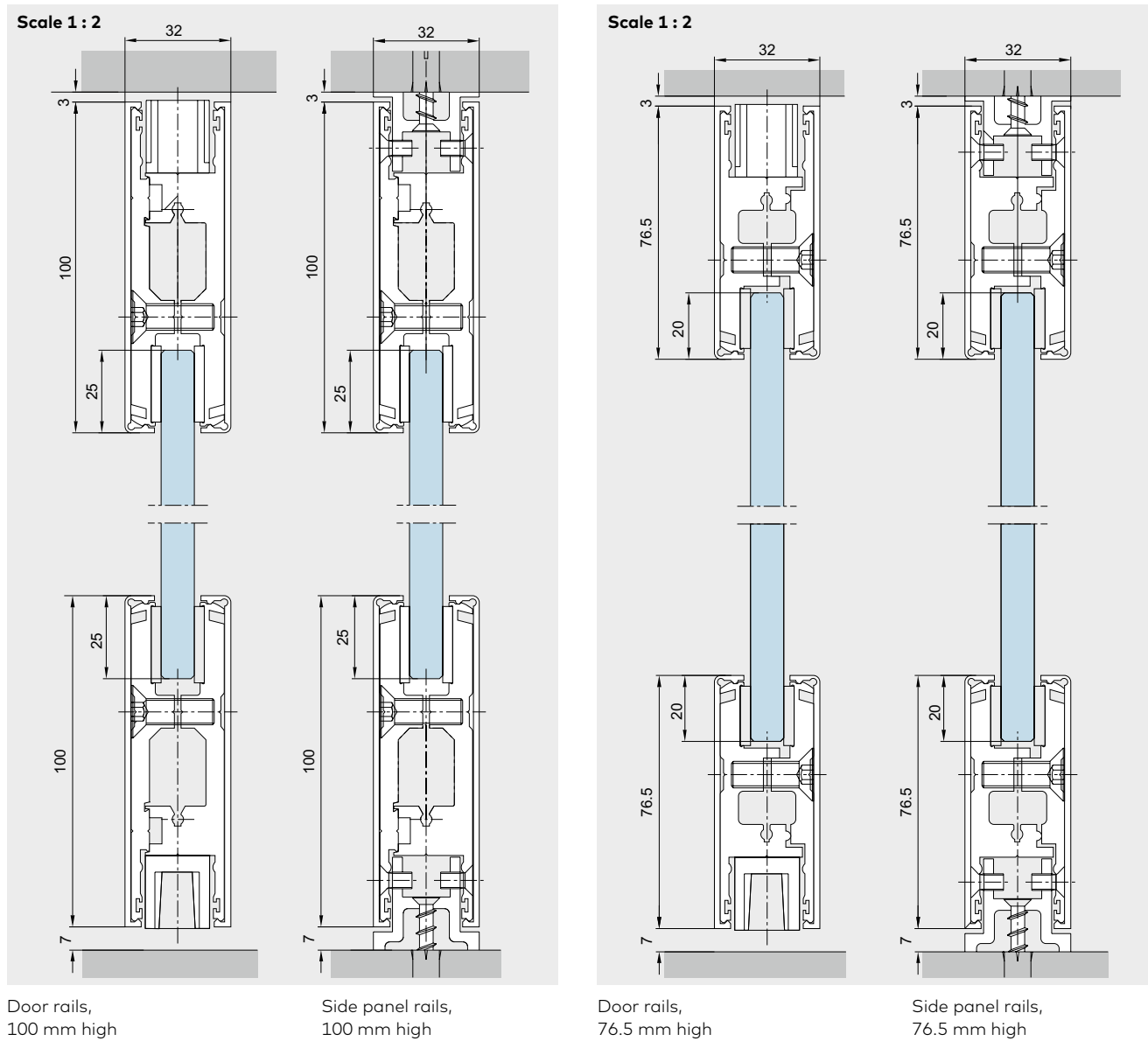

Product description

Art. No.

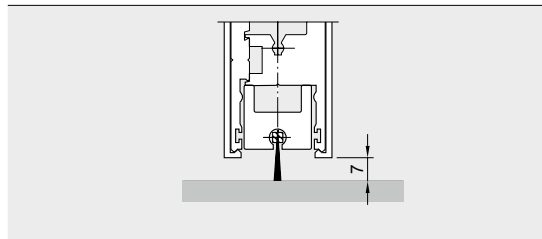

AGILE Aluminum profile brush seal to prevent draughts and energy loss (not in the area of inserts, locks, etc.), connected with door rail at manufacturer

04.600

Weight in kg/m: 0.753

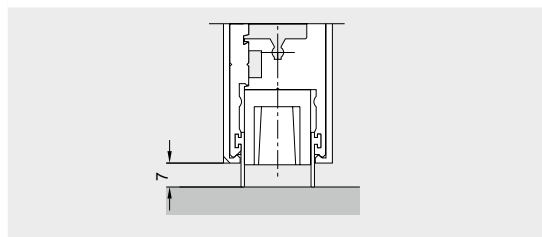

Rubber sealing

for door rails (also in the area of inserts, locks, etc.)
fixed length
stock length 200 m (= 1 coil)

04.607
04.608

Weight in kg/m: 0.099

Construction details

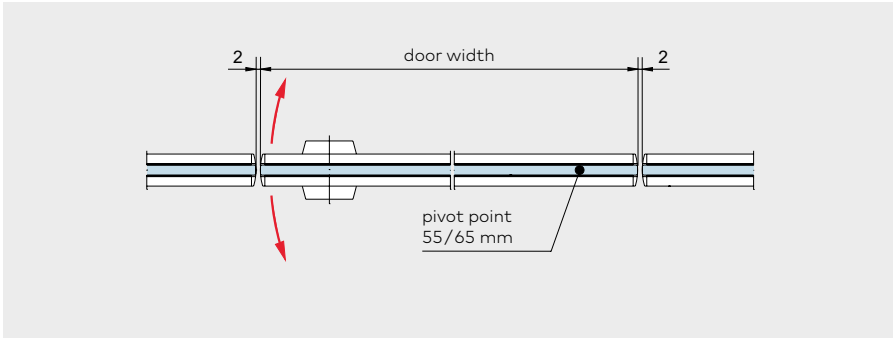

Centre hung doors

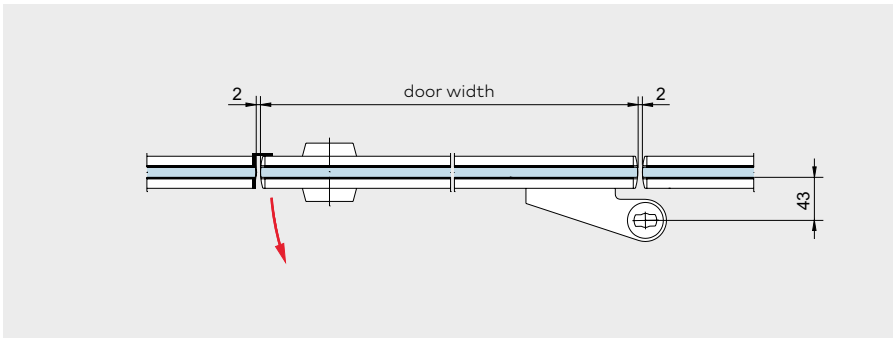

Offset hung door in toughened glass assembly

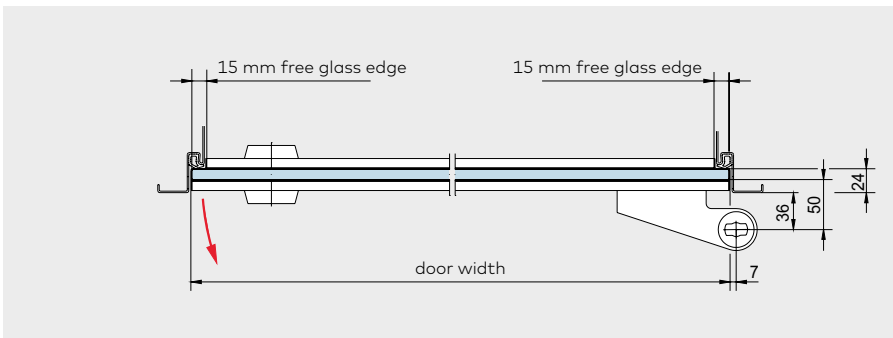

Offset hung door in rebated frame with 24 mm rebate depth

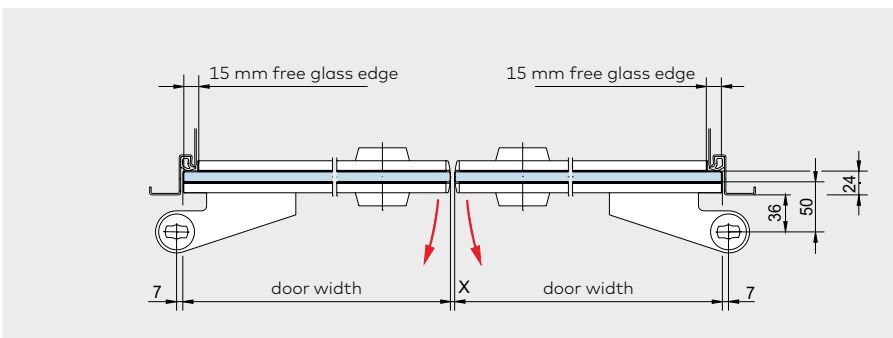

Pair of offset hung doors in rebated frame with 24 mm rebate depth

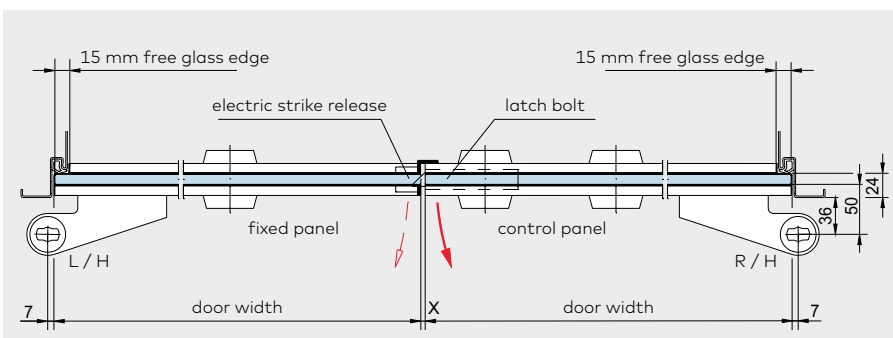

Pair of offset hung doors in rebated frame with 24 mm rebate depth (also available with inserts for centre hung doors), with electric strike release and latch bolt

X = Gap, see table page 105.

Door rails for offset hung doors in toughened glass assemblies without rebated frames

Complete, for 10 mm glass thickness, strap 34 mm, without free glass edges, pivot point to glass surface 43 mm

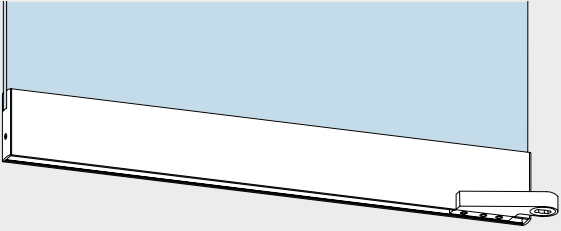
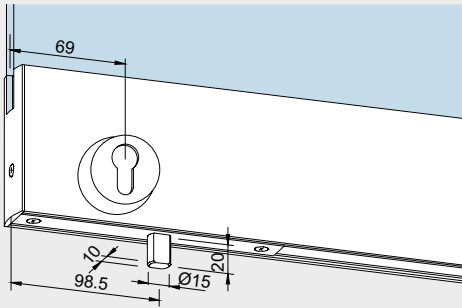
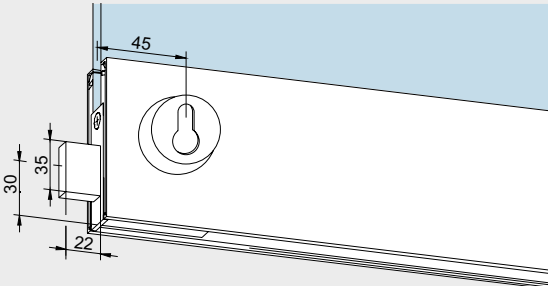
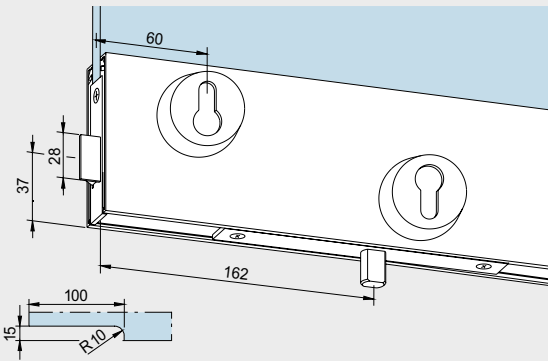
	Product description	Art. No.
	Bottom rail 100 mm:	*04.131/04.133
	Weight in kg/m: Aluminum 5.359 Stainless steel 6.792 76.5 mm:	*04.031/04.033
	...with floor locking lock, prepared for Europrofile cylinder, single throw with corrosion resistant bolt and hardened safety roll pin 100 mm:	*04.151/04.153
	Weight in kg/m: Aluminum 5.694 Stainless steel 7.242 76.5 mm:	*04.051/04.053
	...with side locking lock, prepared for Europrofile cylinder, double throw 100 mm:	*04.171/04.173
	Weight in kg/m: Aluminum 5.592 Stainless steel 7.140	
	...with floor locking lock, prepared for Europrofile cylinder, single throw with corrosion resistant bolt and hardened safety roll pin and latch bolt at side for electric strike release 100 mm:	*04.179/04.181
	Weight in kg/m: Aluminum 6.890 Stainless steel 8.563	

* Left / right hand (illustration shows right hand) are determined by view from hanging side.

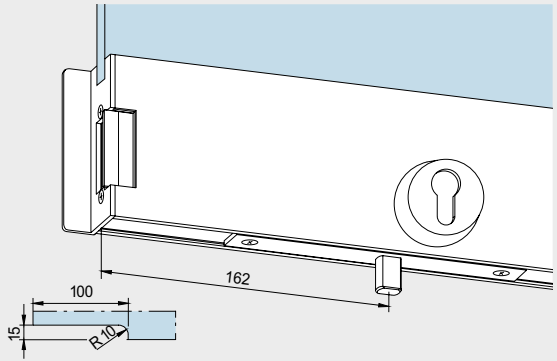
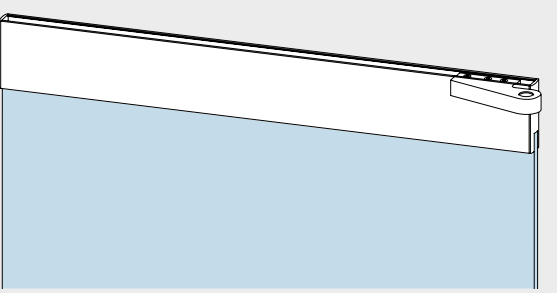
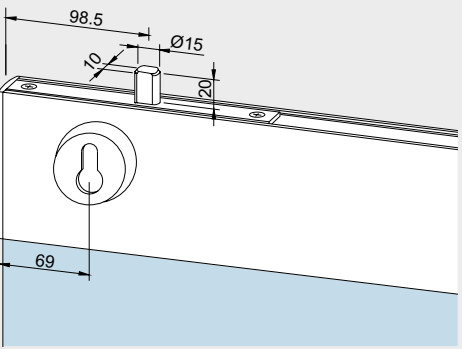
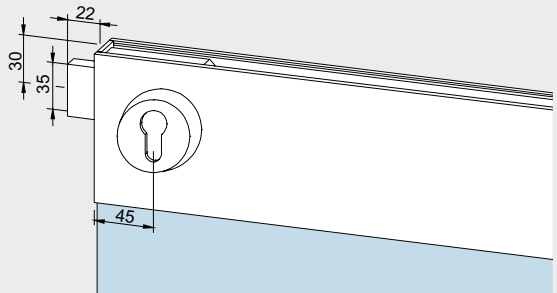
	Product description	Art. No.
	<p>Bottom rail with floor locking lock, prepared for Europrofile cylinder, single throw with corrosion resistant bolt and hardened safety roll pin and electric strike release at side (Standard: fail secure function, 6 to 12 V -/-)</p> <p>100 mm:</p> <p>Weight in kg/m: Aluminum 5.837 Stainless steel 7.385</p>	<p>*04.183/04.185 (zu Art. No. 4.181/04.179)</p>
	<p>Top rail</p> <p>100 mm:</p> <p>Weight in kg/m: Aluminum 5.289 Stainless steel 6.759</p> <p>76.5 mm:</p> <p>Weight in kg/m: Aluminum 4.187 Stainless steel 5.522</p>	<p>*04.132/04.134</p> <p>*04.032/04.034</p>
	<p>...with top locking lock, prepared for Europrofile cylinder, single throw with corrosion resistant bolt and hardened safety roll pin</p> <p>100 mm:</p> <p>Weight in kg/m: Aluminum 5.624 Stainless steel 7.209</p> <p>76,5 mm:</p> <p>Weight in kg/m: Aluminum 4.522 Stainless steel 5.972</p>	<p>*04.152/04.154</p> <p>*04.052/04.054</p>
	<p>...with side locking lock, prepared for Europrofile cylinder, double throw</p> <p>100 mm:</p> <p>Weight in kg/m: Aluminum 5.522 Stainless steel 7.107</p>	<p>*04.172/04.174</p>

* Left / right hand (illustration shows right hand) are determined by view from hanging side.

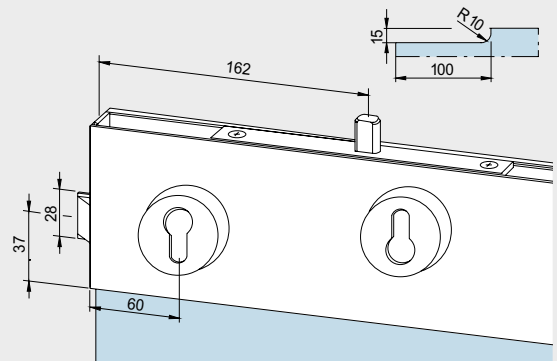
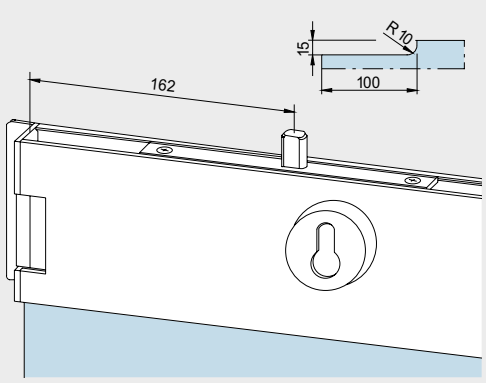
	Product description	Art. No.
	<p>Top rail with top locking lock, prepared for Europrofile cylinder, single throw with corrosion resistant bolt and hardened safety roll pin and latch bolt at side for electric strike release</p> <p>100 mm:</p> <p>Weight in kg/m: Aluminum 6.820 Stainless steel 8.530</p>	<p>**04.180/04.182</p>
	<p>...with top locking lock, prepared for Europrofile cylinder, single throw with corrosion resistant bolt and hardened safety roll pin and electric strike release (Standard: fail secure function, 6 to 12 V -/-)</p> <p>100 mm:</p> <p>Weight in kg/m: Aluminum 5.767 Stainless steel 7.352</p>	<p>*04.184/04.186 (for Art. No. 04.182/04.180)</p>

* Left / right hand (illustration shows right hand) are determined by view from hanging side.

** Left / right hand (illustration shows left hand) are determined by view from hanging side.

Door rails for offset hung doors in rebated frames

With 24 mm rebate depth

Complete, for 10 mm glass thickness, strap 40 mm, with free glass edge left and right, pivot point to glass surface 50 mm
 Also available for rebate depths up to 40 mm.
 If required, please talk to our Application Engineering people.

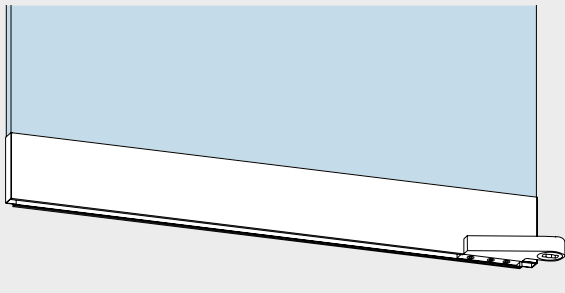
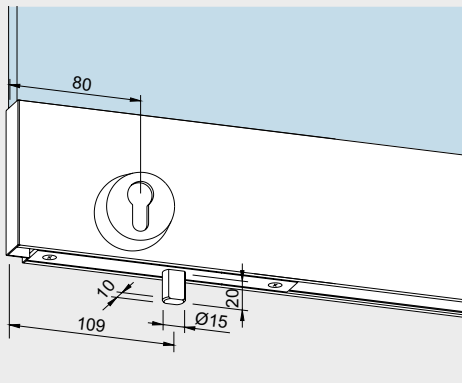
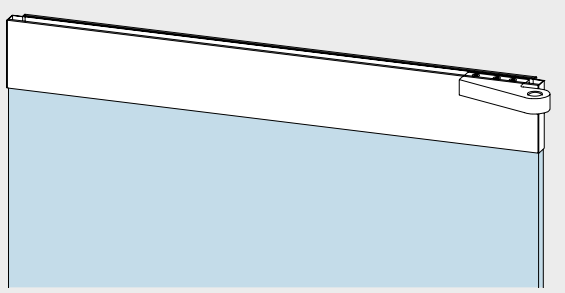
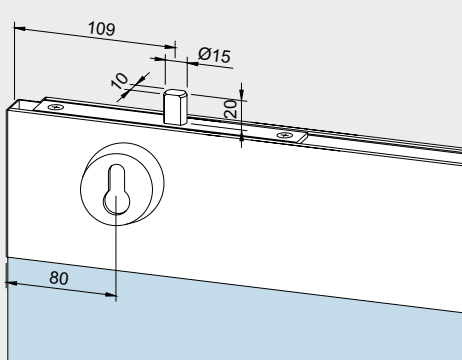
	Product description	Art. No.
	<p>Bottom rail</p> <p>100 mm: *04.135/04.137</p> <p>Weight in kg/m: Aluminum 5.251 Stainless steel 6.602</p> <p>76.5 mm: *04.035/04.037</p> <p>Weight in kg/m: Aluminum 4.181 Stainless steel 5.407</p>	
	<p>...with floor locking lock, prepared for Europrofile cylinder, single throw with corrosion resistant bolt and hardened safety roll pin</p> <p>100 mm: *04.155/04.157</p> <p>Weight in kg/m: Aluminum 5.586 Stainless steel 7.052</p> <p>76.5 mm: *04.055/04.057</p> <p>Weight in kg/m: Aluminum 4.516 Stainless steel 5.857</p>	
	<p>Top rail</p> <p>100 mm: *04.136/04.138</p> <p>Weight in kg/m: Aluminum 5.181 Stainless steel 6.569</p> <p>76.5 mm: *04.036/04.038</p> <p>Weight in kg/m: Aluminum 4.111 Stainless steel 5.374</p>	
	<p>...with top locking lock, prepared for Europrofile cylinder, single throw with corrosion resistant bolt and hardened safety roll pin</p> <p>100 mm: *04.156/04.158</p> <p>Weight in kg/m: Aluminum 5.516 Stainless steel 7.019</p> <p>76.5 mm: *04.056/04.058</p> <p>Weight in kg/m: Aluminum 4.446 Stainless steel 5.824</p>	

* Left / right hand (illustration shows right hand) are determined by view from hanging side.

Door rails for double offset hung doors in rebated frames

With 24 mm rebate depth

Complete, for 10 mm glass thickness, strap 40 mm, with 15 mm free glass edge of hanging stile, pivot point to glass surface 50 mm

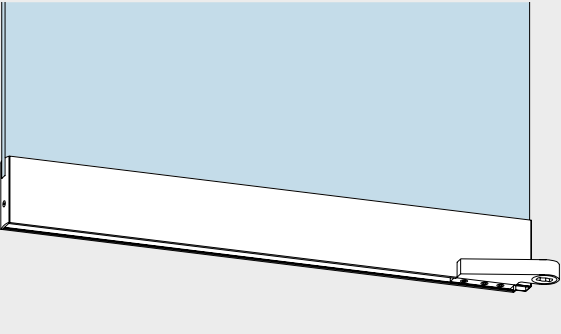
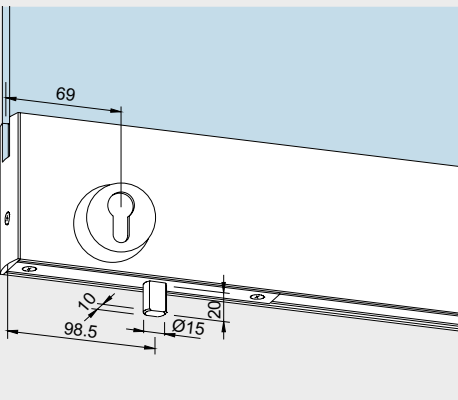
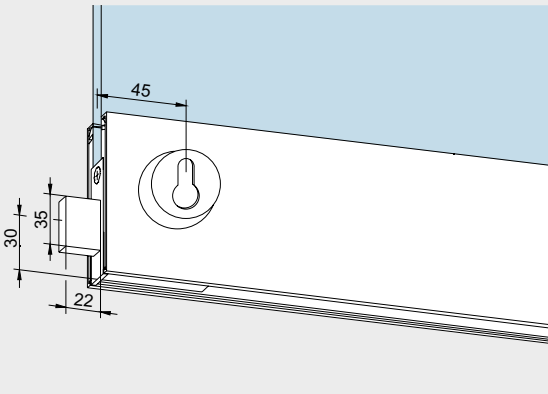
	Product description	Art. No.
	Bottom rail 100 mm:	*04.139/04.141
	Weight in kg/m: Aluminum 5.305 Stainless steel 6.507 76.5 mm:	*04.039/04.041
	...with floor locking lock, prepared for Europrofile cylinder, single throw with corrosion resistant bolt and hardened safety roll pin 100 mm:	*04.159/04.161
	Weight in kg/m: Aluminum 5.640 Stainless steel 6.957 76.5 mm:	*04.059/04.061
	...with side locking lock, prepared for Europrofile cylinder, double throw 100 mm:	*04.175/04.177
	Weight in kg/m: Aluminum 5.538 Stainless steel 6.855	

* Left / right hand (illustration shows right hand) are determined by view from hanging side.

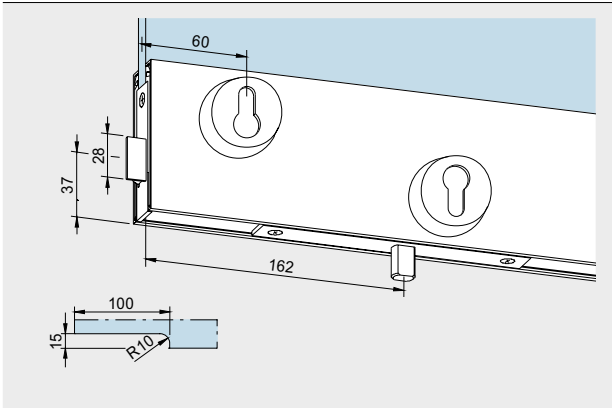
Product description**Art. No.****Bottom rail**

with floor locking bolt lock,
prepared for Europrofile cylinder, single throw with
corrosion resistant bolt and hardened safety roll
pin and latch lock at side for electric strike release

100 mm:

***04.143/04.145**

Weight in kg/m:

Aluminum	5.803
Stainless steel	7.306

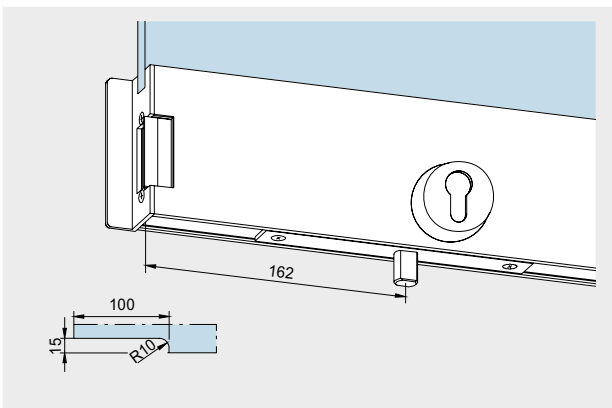

...with floor locking bolt lock, prepared for Europrofile
cylinder, single throw with corrosion resistant
bolt and hardened safety roll pin and electric strike
release at side (Standard: fail secure function,
6 to 12 V -/-)

100 mm:

***04.147/04.149**

Weight in kg/m:

Aluminum	5.653
Stainless steel	7.150

* Left / right hand (illustration shows right hand) are determined by view from hanging side.

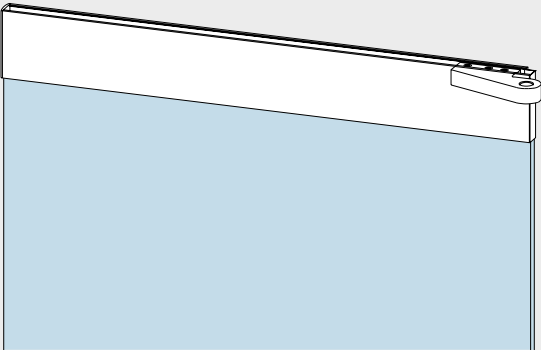
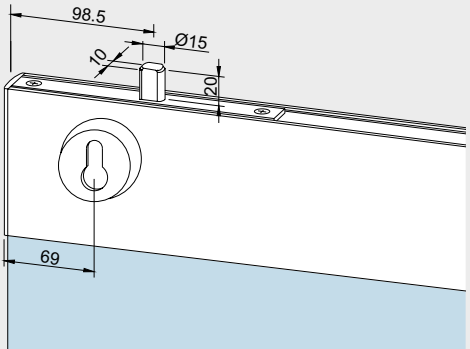
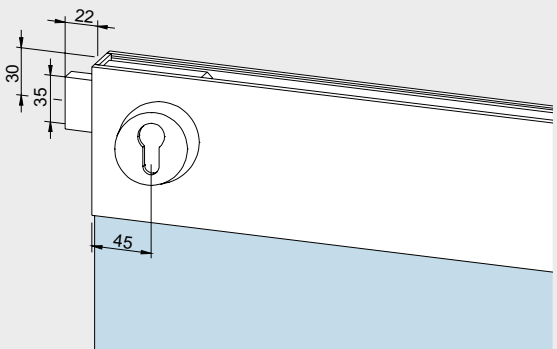
	Product description	Art. No.
	<p>Top rail 100 mm:</p> <p>Weight in kg/m: Aluminum 5.235 Stainless steel 6.474</p> <p>76.5 mm:</p> <p>Weight in kg/m: Aluminum 4.149 Stainless steel 5.449</p>	<p>*04.140/04.142</p> <p>*04.040/04.042</p>
	<p>...with top locking lock, prepared for Europrofile cylinder, single throw with corrosion resistant bolt and hardened safety roll pin</p> <p>100 mm:</p> <p>Weight in kg/m: Aluminum 5.570 Stainless steel 6.924</p> <p>76.5 mm:</p> <p>Weight in kg/m: Aluminum 4.484 Stainless steel 5.899</p>	<p>*04.160/04.162</p> <p>*04.060/04.062</p>
	<p>...with side locking lock, prepared for Europrofile cylinder, double throw</p> <p>100 mm:</p> <p>Weight in kg/m: Aluminum 5.468 Stainless steel 6.822</p>	<p>*04.176/04.178</p>

* Left / right hand (illustration shows right hand) are determined by view from hanging side.

Product description

Art. No.

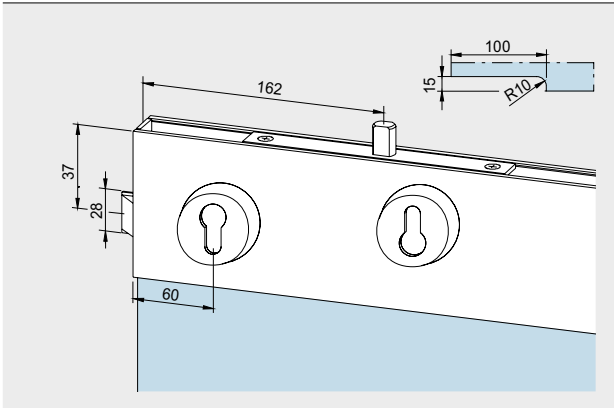

Top rail

with top locking lock, prepared for Europrofile cylinder, single throw with corrosion resistant bolt and hardened safety roll pin and latch bolt at side for electric strike release

100 mm:

Weight in kg/m:
 Aluminum 5.733
 Stainless steel 7.236

***04.144/04.146**

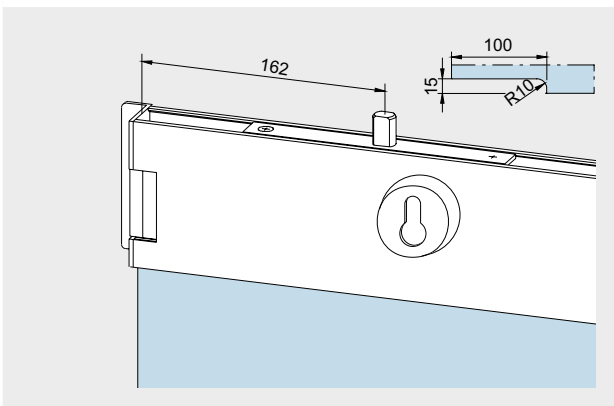

...with top locking bolt lock, prepared for Europrofile cylinder, single throw with corrosion resistant bolt and hardened safety roll pin and electric strike release at side (Standard: fail secure function, 6 to 12 V -/-)

100 mm:

Weight in kg/m:
 Aluminum 5.583
 Stainless steel 7.080

****04.148/04.150**
 (for Art. No. 04.182/04.180)

* Left / right hand (illustration shows left hand) are determined by view from hanging side
 ** Left / right hand (illustration shows right hand) are determined by view from hanging side.

Door rails for double-action doors

Pivot point 55/65 mm

Complete, for 10 mm glass thickness

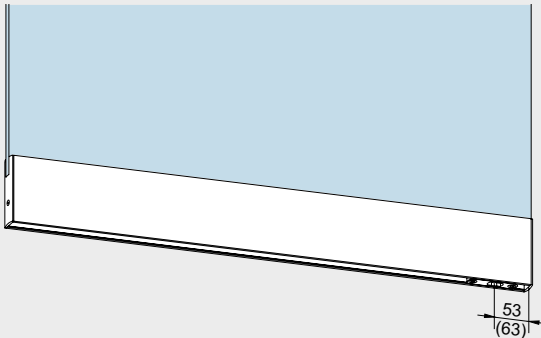
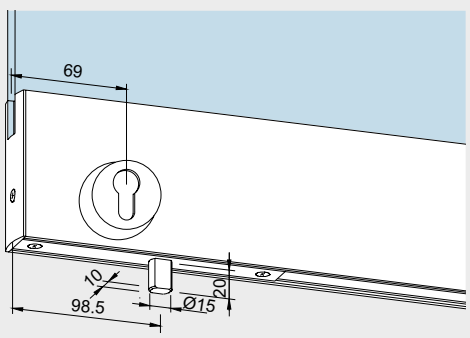
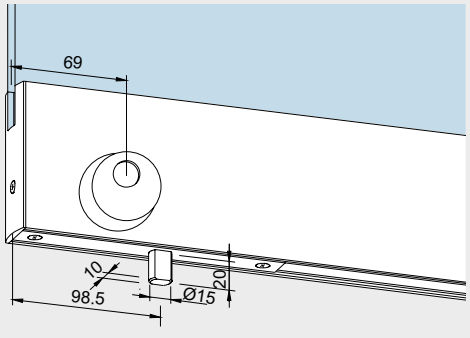
	Product description	Art. No.
	<p>Bottom rail with stainless steel insert to suit floor spring spindle or round pivot 14 mm Ø</p> <p>100 mm: 04.101</p> <p>Weight in kg/m: Aluminum 5.131 Stainless steel 6.070</p> <p>76.5 mm: 04.001</p> <p>Weight in kg/m: Aluminum 4.029 Stainless steel 4.833</p>	
	<p>...with floor locking lock, prepared for Europrofile cylinder, single throw with corrosion resistant bolt and hardened safety roll pin</p> <p>100 mm: 04.111</p> <p>Weight in kg/m: Aluminum 5.466 Stainless steel 6.520</p> <p>76.5 mm: 04.011</p> <p>Weight in kg/m: Aluminum 4.364 Stainless steel 5.283</p>	
	<p>...with floor locking lock, prepared for KABA, single throw with corrosion resistant bolt and hardened safety roll pin</p> <p>100 mm: 04.163 (not illustr.)</p> <p>Weight in kg/m: Aluminum 5.466 Stainless steel 6.520</p> <p>76.5 mm: 04.063 (not illustr.)</p> <p>Weight in kg/m: Aluminum 4.364 Stainless steel 5.283</p>	

	Product description	Art. No.
	<p>...with side locking lock, prepared for Europrofile cylinder, double throw</p> <p>100 mm:</p> <p>Weight in kg/m: Aluminum 5.364 Stainless steel 6.418</p>	<p>04.121</p>
	<p>Bottom rail</p> <p>with latch lock at side for electric strike release and floor locking bolt lock, prepared for Europrofile cylinder, single throw with corrosion resistant bolt and hardened safety roll pin. The use of latch lock or electric strike release results from a single-action door situation.</p> <p>Weight in kg/m: Aluminum 6.667 Stainless steel 8.335</p>	<p>*04.191/04.193</p>
	<p>...with electric strike release at side</p> <p>(Standard: fail secure function, 6 to 12 V -/-) and floor locking bolt lock, prepared for Europrofile cylinder, single throw with corrosion resistant bolt and hardened safety roll pin. The use of latch lock or electric strike release result from a single-action door situation.</p> <p>Weight in kg/m: Aluminum 5.586 Stainless steel 6.640</p>	<p>*04.196/04.198</p>

* Order of Art.No.: Left hand / right hand – determined by view from hanging side.(Illustration shows right hand)

	Product description	Art. No.
	<p>Top rail with insert to take 15 mm Ø pivot pin</p> <p>100 mm:</p> <p>Weight in kg/m: Aluminum 4.979 Stainless steel 5.918</p> <p>76.5 mm:</p> <p>Weight in kg/m: Aluminum 3.877 Stainless steel 4.681</p>	<p>04.102</p> <p>04.002</p>
	<p>...and top locking lock, prepared for Europrofile cylinder, single throw with corrosion resistant bolt and hardened safety roll pin</p> <p>100 mm:</p> <p>Weight in kg/m: Aluminum 5.466 Stainless steel 6.368</p> <p>76.5 mm:</p> <p>Weight in kg/m: Aluminum 4.212 Stainless steel 5.131</p>	<p>04.112</p> <p>04.012</p>
	<p>...with top locking lock prepared for KABA, single throw with corrosion resistant bolt and hardened safety roll pin</p> <p>100 mm:</p> <p>Weight in kg/m: Aluminum 5.314 Stainless steel 6.368</p> <p>76.5 mm:</p> <p>Weight in kg/m: Aluminum 4.212 Stainless steel 5.131</p>	<p>04.163 (not illustr.)</p> <p>04.063 (not illustr.)</p>

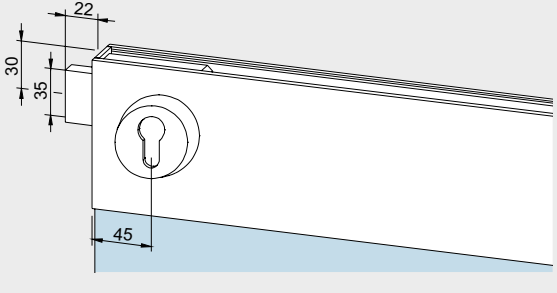
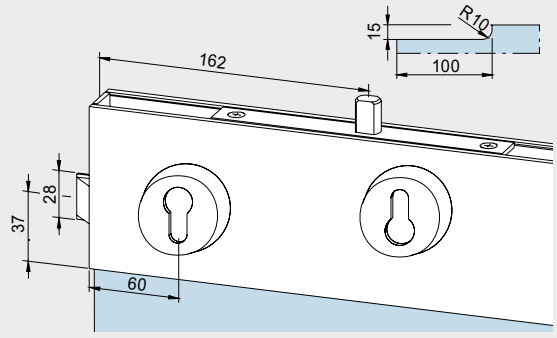
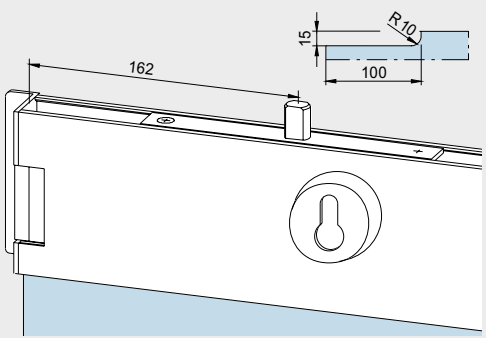
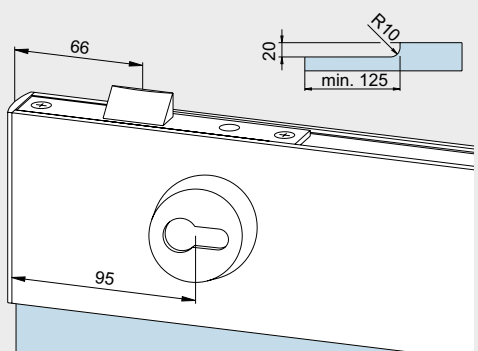
	Product description	Art. No.
	<p>Top rail with side locking lock, prepared for Europrofile cylinder, double throw</p> <p>100 mm:</p> <p>Weight in kg/m: Aluminum 5.212 Stainless steel 6.266</p>	<p>04.122</p>
	<p>...with latch lock at side for electric strike release and top locking bolt lock, prepared for Europrofile cylinder, single throw with corrosion resistant bolt and hardened safety roll pin. The use of latch lock or electric strike release results in a single-action door situation.</p> <p>Weight in kg/m: Aluminum 6.592 Stainless steel 8.148</p>	<p>*04.192/04.194</p>
	<p>...with electric strike release at side (Standard: fail secure function, 6 to 12 V -/-) and top locking bolt lock, prepared for Europrofile cylinder, single throw with corrosion resistant bolt and hardened safety roll pin. The use of latch lock or electric strike release results in a single-action door situation.</p> <p>Weight in kg/m: Aluminum 6.492 Stainless steel 8.048</p>	<p>**04.197/04.199</p>
	<p>...with latch lock, locking to ceiling, prepared for Europrofile cylinder, single throw (necessary stop on site). The use of latch lock or electric strike release (on site) results in a single-action door situation.</p> <p>100 mm:</p> <p>Weight in kg/m: Aluminum 5.294 Stainless steel 6.348</p>	<p>04.118</p>

* Left / right hand (illustration shows left hand) are determined by view from hanging side.

** Left / right hand (illustration shows right hand) are determined by view from hanging side.

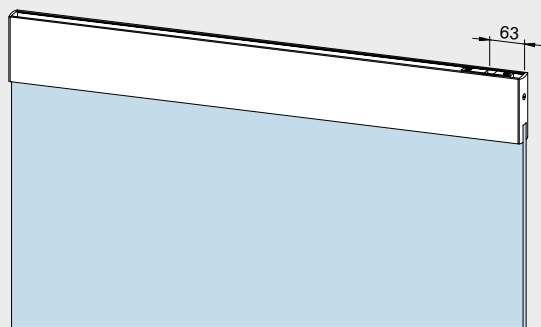
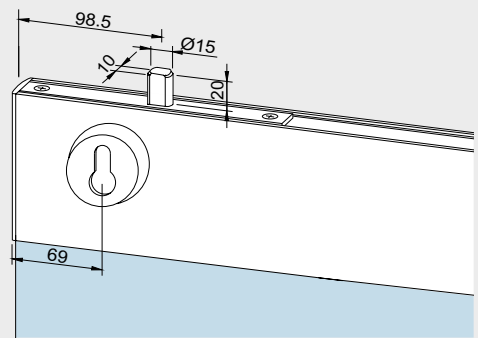
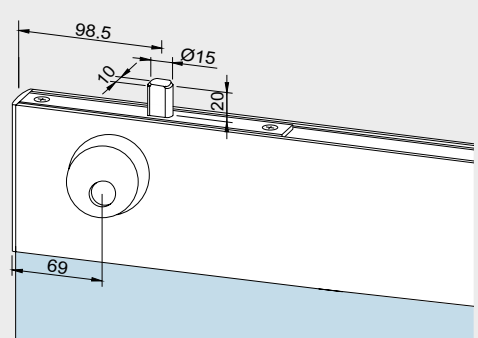
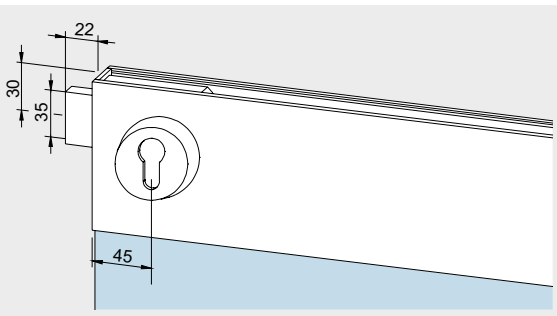
	Product description	Glass thickness	Art. No.
	<p>Top rail with insert for RTS transom closer</p> <p>100 mm:</p> <p>Weight in kg/m: Aluminum 5.145 Stainless steel 6.207</p> <p>76.5 mm:</p> <p>Weight in kg/m: Aluminum 4.043 Stainless steel 4.847</p>		<p>04.106</p> <p>04.006</p>
	<p>...and top locking lock, prepared for Euro-profile cylinder, single throw with corrosion resistant bolt and hardened safety roll pin</p> <p>100 mm:</p> <p>Weight in kg/m: Aluminum 5.480 Stainless steel 6.657</p> <p>76.5 mm:</p> <p>Weight in kg/m: Aluminum 4.378 Stainless steel 5.297</p>		<p>04.116</p> <p>04.016</p>
	<p>...with top locking lock prepared for KABA, single throw with corrosion resistant bolt and hardened safety roll pin</p> <p>100 mm:</p> <p>Weight in kg/m: Aluminum 5.480 Stainless steel 6.655</p> <p>76.5 mm:</p> <p>Weight in kg/m: Aluminum 5.145 Stainless steel 6.207</p>		<p>04.167</p> <p>04.067</p>
	<p>...and side locking lock, prepared for Euro-profile cylinder, double throw</p> <p>100 mm:</p> <p>Weight in kg/m: Aluminum 5.378 Stainless steel 6.555</p> <p>Not illustrated: Gasket (1 m = 1 pc.)</p>	<p>8 mm 12 mm</p>	<p>04.126</p> <p>01.900 01.901</p>

Door rails for double-action doors

Pivot point 18 mm

Complete, for 10 mm glass thickness

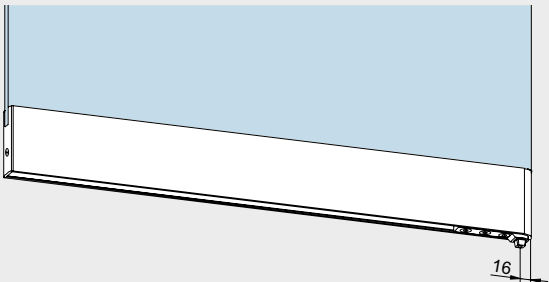
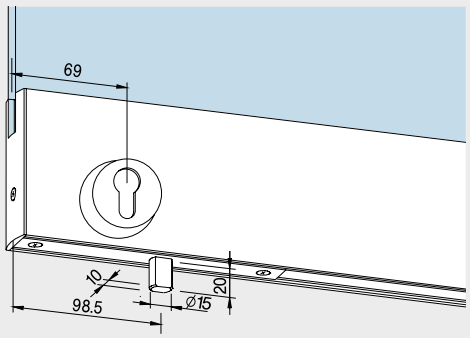
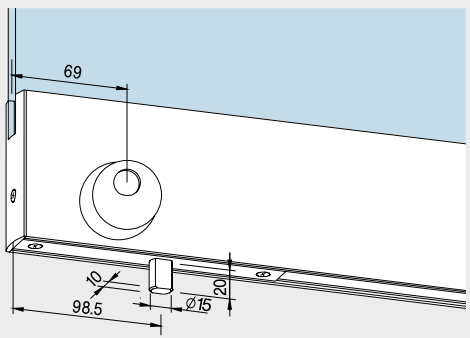
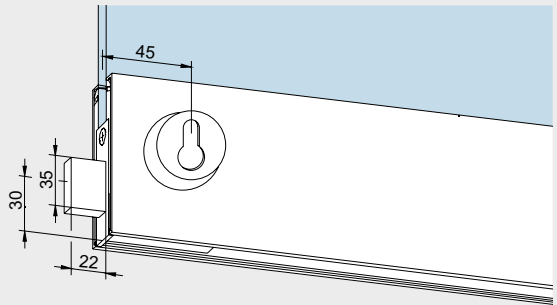
	Product description	Art. No.
	<p>Bottom rail with floor spring spindle insert</p> <p>100 mm: 04.103</p> <p>Weight in kg/m: Aluminum 5.218 Stainless steel 6.193</p> <p>76.5 mm: 04.003</p> <p>Weight in kg/m: Aluminum 4.126 Stainless steel 4.824</p>	
	<p>...with floor locking lock, prepared for Europrofile cylinder, single throw with corrosion resistant bolt and hardened safety roll pin</p> <p>100 mm: 04.113</p> <p>Weight in kg/m: Aluminum 5.553 Stainless steel 6.643</p> <p>76.5 mm: 04.013</p> <p>Weight in kg/m: Aluminum 4.461 Stainless steel 5.274</p>	
	<p>...with floor locking lock prepared for KABA, single throw (not illustrated) with corrosion resistant bolt and hardened safety roll pin</p> <p>100 mm: 04.165</p> <p>Weight in kg/m: Aluminum 5.553 Stainless steel 6.664</p> <p>76.5 mm: 04.065</p> <p>Weight in kg/m: Aluminum 5.228 Stainless steel 6.280</p>	
	<p>...with side locking lock, prepared for Europrofile cylinder, double throw</p> <p>100 mm: 04.123</p> <p>Weight in kg/m: Aluminum 5.451 Stainless steel 6.541</p>	

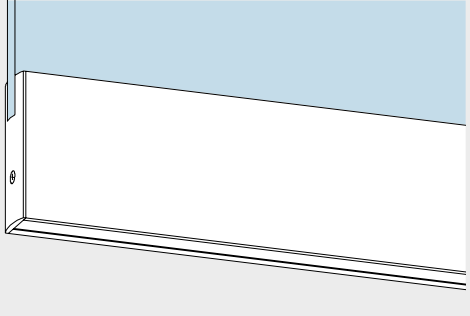
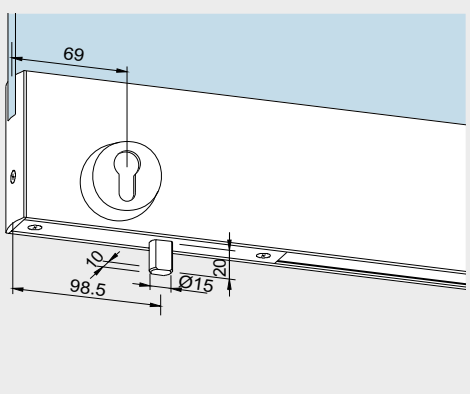
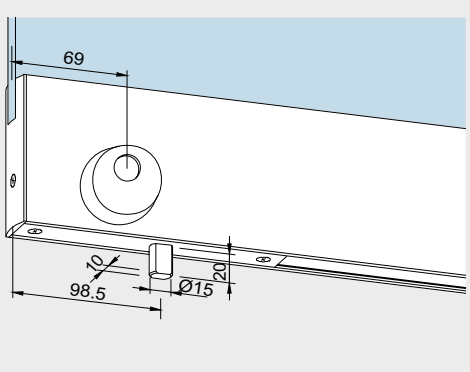
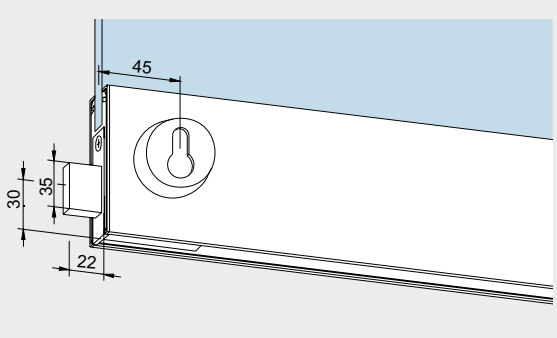
	Product description	Art. No.
	<p>...prepared for floor bearing</p> <p>100 mm:</p> <p>Weight in kg/m:</p> <p>Aluminum 4.938</p> <p>Stainless steel 5.975</p> <p>76.5 mm:</p> <p>Weight in kg/m:</p> <p>Aluminum 3.898</p> <p>Stainless steel 4.606</p>	<p>04.107</p> <p>04.007</p>
	<p>Bottom rail with floor locking lock, prepared for Europrofile cylinder, single throw with corrosion resistant bolt and hardened safety roll pin, prepared for floor bearing</p> <p>100 mm:</p> <p>Weight in kg/m:</p> <p>Aluminum 5.334</p> <p>Stainless steel 6.425</p> <p>76.5 mm:</p> <p>Weight in kg/m:</p> <p>Aluminum 4.243</p> <p>Stainless steel 5.056</p>	<p>04.117</p> <p>04.017</p>
	<p>...with floor locking lock prepared for KABA, single throw with corrosion resistant bolt and hardened safety roll pin, prepared for floor bearing</p> <p>100 mm:</p> <p>Weight in kg/m:</p> <p>Aluminum 5.334</p> <p>Stainless steel 6.425</p> <p>76.5 mm:</p> <p>Weight in kg/m:</p> <p>Aluminum 4.243</p> <p>Stainless steel 5.056</p>	<p>04.168</p> <p>04.068</p>
	<p>...with side locking lock, prepared for Europrofile cylinder, double throw, prepared for floor bearing</p> <p>100 mm:</p> <p>Weight in kg/m:</p> <p>Aluminum 5.233</p> <p>Stainless steel 6.323</p>	<p>04.127</p>

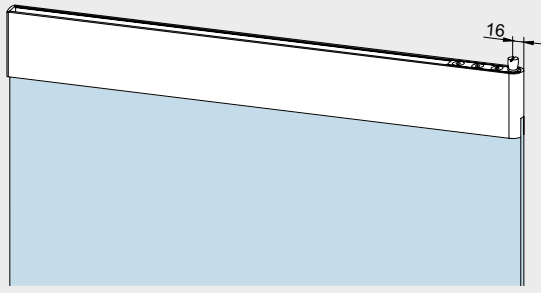
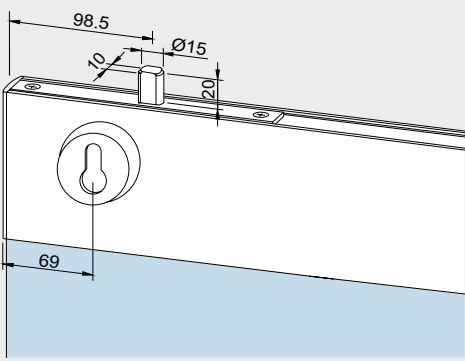
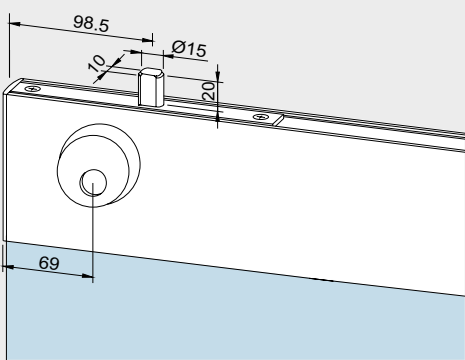
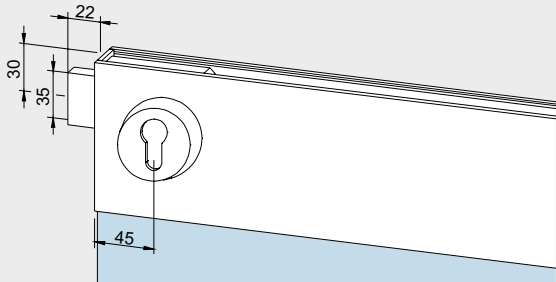
	Product description	Art. No.
	<p>Top rail with 15 mm Ø pivot pin</p> <p>100 mm:</p> <p>Weight in kg/m: Aluminum 5.000 Stainless steel 5.975</p> <p>76.5 mm:</p> <p>Weight in kg/m: Aluminum 3.908 Stainless steel 4.606</p>	<p>04.104</p> <p>04.004</p>
	<p>...and top locking lock, prepared for Europrofile cylinder, single throw with corrosion resistant bolt and hardened safety roll pin</p> <p>100 mm:</p> <p>Weight in kg/m: Aluminum 5.335 Stainless steel 6.425</p> <p>76.5 mm:</p> <p>Weight in kg/m: Aluminum 4.243 Stainless steel 5.056</p>	<p>04.114</p> <p>04.014</p>
	<p>...with top locking lock prepared for KABA, single throw with corrosion resistant bolt and hardened safety roll pin</p> <p>100 mm:</p> <p>Weight in kg/m: Aluminum 5.335 Stainless steel 6.425</p> <p>76.5 mm:</p> <p>Weight in kg/m: Aluminum 4.243 Stainless steel 5.056</p>	<p>04.166</p> <p>04.066</p>
	<p>...with side locking lock, prepared for Europrofile cylinder, double throw</p> <p>100 mm:</p> <p>Weight in kg/m: Aluminum 5.233 Stainless steel 6.323</p>	<p>04.124</p>

Radiused edging strip

Acryl, transparent, to clamp onto free glass edge. For optimal pinch protection. For application with door rails with 18 mm pivot point.

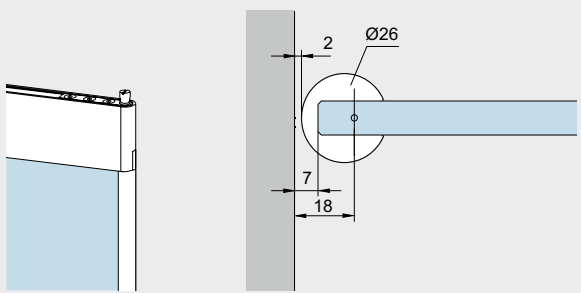
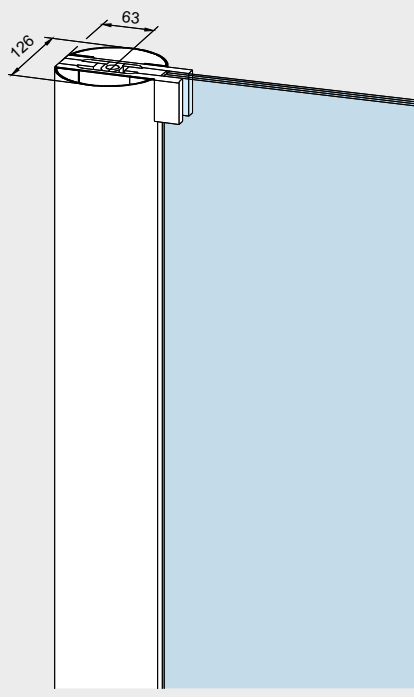
	Product description	Glass thickness	Art. No.
	<p>Radiused edging strip Please indicate door height and type of fitting with order.</p> <p>up to 4,500 mm length fixed length: 2,250 mm</p> <p>Notice: When radiused edging strip is used the following glass measurement is valid = door rail width – 5 mm. TSG only.</p>	<p>10 mm 10 mm</p>	<p>01.231 01.230</p>
	<p>Aluminum round profile for pinch free doors with 65 mm pivot point, consisting of 2 halves, prepared for UNIVERSAL fittings or door rails (76.5 mm or 100 mm).</p> <p>Please indicate:</p> <ul style="list-style-type: none"> • Panel height (max. 2,500 mm, higher dimension on request) • Required preparation of the profile for top and bottom fittings <p>Aluminum round profile, as above, stock length 6,000 mm (unprepared)</p> <p>Aluminum round profile, as above, stock length 3,000 mm (unprepared)</p> <p>Aluminum round profile, as above, stock length 2,800 mm (unprepared)</p> <p>Weight in kg/m: Aluminum 4.744</p>		<p>03.380</p> <p>03.381</p> <p>03.382</p> <p>03.383</p>

Rails for side panel

complete, for 10 mm glass thickness

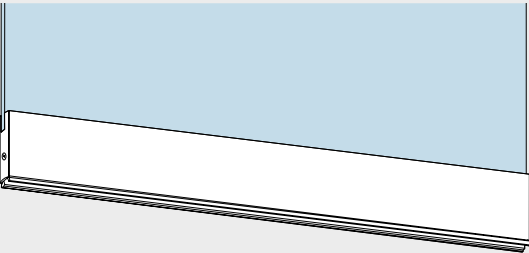
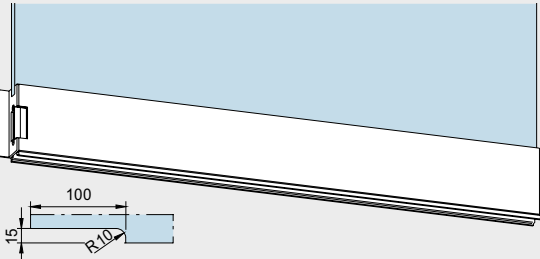
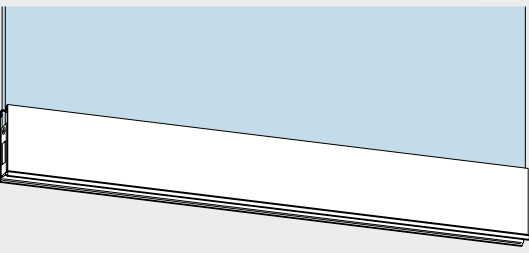
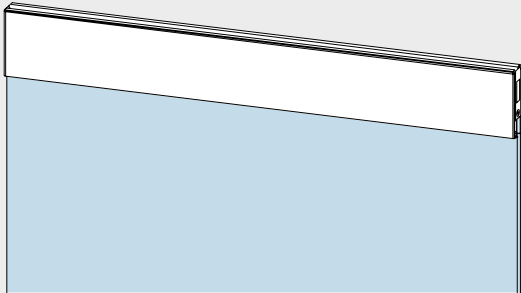
	Product description	Art. No.
	<p>Bottom rail for side panel, up to approx. 6,000 mm long with rail filler insert 7 mm</p> <p>100 mm: 04.301</p> <p>Weight in kg/m: Aluminum 5,604 Stainless steel 6,494</p> <p>76.5 mm: 04.201</p> <p>Weight in kg/m: Aluminum 4,504 Stainless steel 5,273</p>	
	<p>...with electric strike release (standard: fail secure function, 6 to 12 V -/-), door width up to max. 1,200 mm (> 1,200 mm on request)</p> <p>100 mm: *04.311/04.313</p> <p>Weight in kg/m: Aluminum 5,116 Stainless steel 6,055</p>	
	<p>...with strike-box for side bolt locking, door width up to max. 1,200 mm (> 1,200 mm on request)</p> <p>100 mm: 04.315</p> <p>Weight in kg/m: Aluminum 4,979 Stainless steel 5,918</p>	
	<p>Top rail for side panel, up to approx. 6,000 mm long with rail filler insert 3 mm</p> <p>100 mm: 04.302</p> <p>Weight in kg/m: Aluminum 5,441 Stainless steel 6,331</p> <p>76.5 mm: 04.202</p> <p>Weight in kg/m: Aluminum 4,341 Stainless steel 5,110</p>	

* Left / right hand (illustration shows right hand) are determined by view from hanging side.

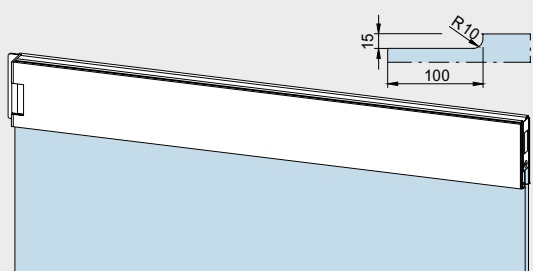
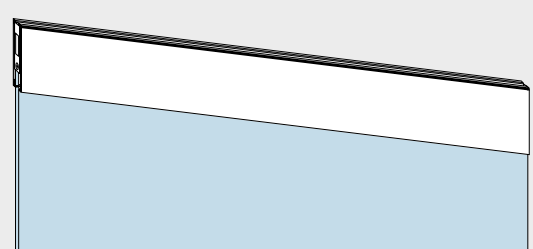
	Product description	Art. No.
	<p>...with electric strike release (standard: fail secure function, 6 to 12 V -/-)</p> <p>100 mm:</p> <p>Weight in kg/m: Aluminum 5.578 Stainless steel 6.468</p>	<p>*04.312/04.314</p>
	<p>...with strike-box for side bolt locking</p> <p>100 mm:</p> <p>Weight in kg/m: Aluminum 5.441 Stainless steel 6.331</p>	<p>04.316</p>

* Left / right hand (illustration shows right hand) are determined by view from hanging side.

Space for your notes

Top centre frame portion

with patch fittings see EA

	Product description	Art. No.
	<p>Frame top centre with fixing block</p> <p>Weight in kg/m: Aluminum 0.471</p>	<p>02.150</p>
	<p>Frame top centre with angle bracket</p> <p>Weight in kg/m: Aluminum 0.453</p>	<p>02.151</p>
	<p>Frame top centre with special wedge screw fixings</p> <p>Weight in kg/m: Aluminum 0.390</p> <p>Drill jig:</p>	<p>*02.152/02.153</p> <p>8.02.081.001.50</p>
	<p>Frame top centre AT 212 GSR with fixing plate</p> <p>Weight in kg/m: Stainless steel 0.215</p>	<p>*02.340/02.341</p>

* Left / right hand (illustration shows right hand) are determined by view from hanging side.

Special accessories and special inserts for door rails

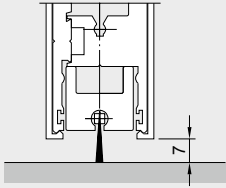
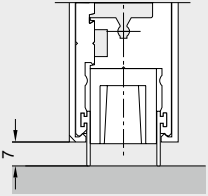
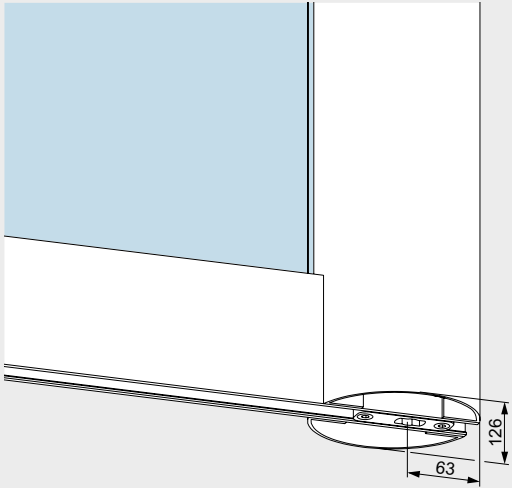
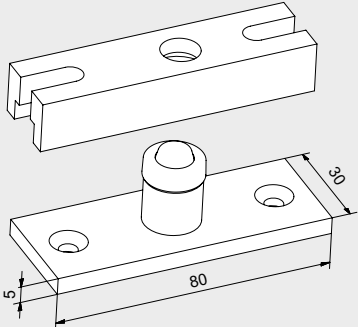
	Product description	Art. No.
	<p>Aluminum profile with brush seal to prevent draughts and energy loss (not in the area of inserts, locks, etc.), connected with door rail at manufacturer</p> <p>Weight in kg/m: 0.753</p>	<p>04.600</p>
	<p>Rubber sealing for door rails (also in the area of inserts, locks, etc.)</p> <p>fixed length stock length 200 m (= 1 coil)</p> <p>Weight in kg/m: 0.099</p>	<p>04.607 04.608</p>
	<p>Aluminum round profile for pinch free doors with 65 mm pivot point, consisting of 2 halves, prepared for UNIVERSAL fittings* or door rails (76.5 mm or 100 mm). Please indicate:</p> <ul style="list-style-type: none"> • Panel height (max. 3,000 mm, higher dim. on request) • Required preparation of the profile for top and bottom fittings <p>fixed length</p> <p>Weight in kg/m: Aluminum 4.744</p> <p>stock length 6,000 mm (not prepared) stock length 3,000 mm (not prepared)</p>	<p>03.380</p> <p>03.381 03.382</p>
	<p>Screw-on floor bearing for damp environment, without floor recess, with inserts for door rails, max. 80 kg</p> <p>Weight in kg/m: 0.193</p>	<p>01.136</p>

*Information as to the product UNIVERSAL you may find in the technical brochure "Patch fittings for toughened glass assemblies"

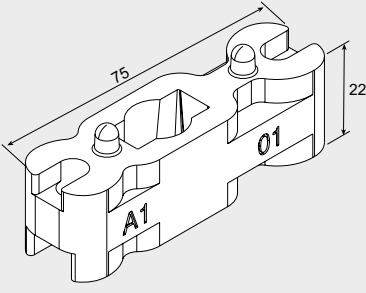
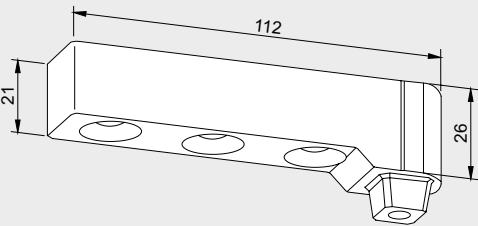
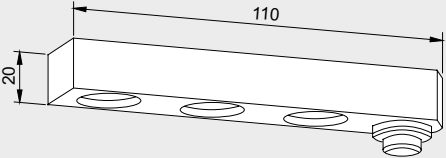
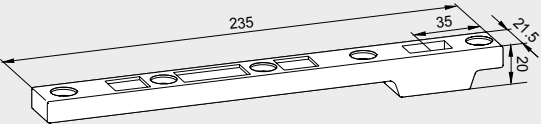
	Product description	Art. No.
	<p>Bottom insert for floor spring spindle profile or round pivot 14 mm Ø, (floor spring BTS or floor bearing Art. No. 01.106 and 01.107), stainless steel, 55/65 mm pivot point, max. door weight 80 kg</p> <p>Weight in kg/m: 0.243</p>	<p>04.604</p>
	<p>Bottom strap, steel, zinc plated, with spindle insert to suit floor springs, 18 mm pivot point, max. door weight 80 kg</p> <p>Weight in kg/m: 0.349</p>	<p>804.167.001.55</p>
	<p>Bottom strap, aluminum, to suit floor bearings 01.106 and 01.107, 18 mm pivot point, max. door weight 80 kg</p> <p>Weight in kg/m: 0.129</p>	<p>804.060.002.50</p>
	<p>Bottom strap in forged steel special edition, mounted in door rails, to suit floor spring spindles. (Also suitable for floor bearing 04.602, 04.603. Not suitable for floor bearing with round pivot.) For centre hung doors</p> <ul style="list-style-type: none"> • normal frequented doors, max. door weight 150 kg, max. door width 1,400 mm • high frequented doors, max. door weight 120 kg, max. door width 1,200 mm <p>Pivot point either 55 or 65 mm (please specify with order).</p> <p>Weight in kg/m: 0.385</p>	<p>04.605</p>

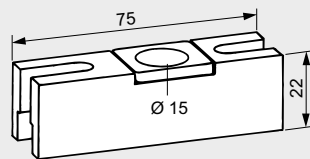
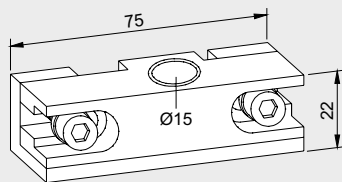
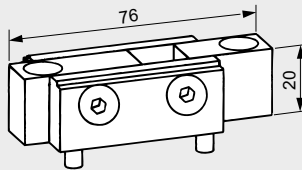
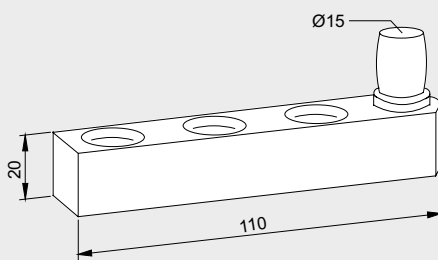
	Product description	Art. No.
	<p>Top insert 55/65 mm pivot point, Aluminum</p> <p>Weight in kg/m: 0.091</p>	<p>04.610</p>
	<p>Top insert, two part, Aluminum, special, 55/65 mm pivot point not in standard door rail</p> <p>Weight in kg/m: 0.088</p>	<p>04.606</p>
	<p>Top insert for RTS transom closer, zinc plated steel, 65 mm pivot point</p> <p>Weight in kg/m: 0.240</p>	<p>04.611</p>
	<p>Top strap Aluminum, 18 mm pivot point</p> <p>Weight in kg/m: 0.131</p>	<p>804.060.001.50</p>

Content

MANET Compact

134	General information
151	Type illustrations
188	Accessories
212	Safety-related information



MANET
Compact

MANET Compact sets

The aesthetic elegance of the MANET Compact concept is also available in the form of standardized sets for simple, fast planning of the more popular system types.

Optional accessories enable the individual sets to be semi-customized. The system components offer numerous adjustment possibilities in order to ensure problem-free installation of whichever door type – swing or single-action or double-action – is required. Wall abutment profiles may need to be provided (by others) for fixing overpanels and sidelights.



Pivoting fitting short type,
 max. door panel height 2,500 mm
 max. door panel width 1,200 mm
 max. door panel weight 80 kg

Pivoting fitting short type with intermediate tube,
 max. door panel height 2,500 mm
 max. door panel width 1,200 mm
 max. door panel weight 80 kg

Countersunk bore for countersunk single-point fixings

Cylindrical bore for clamping disc single-point fixings

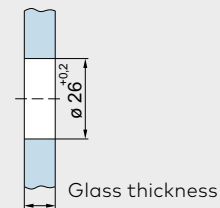
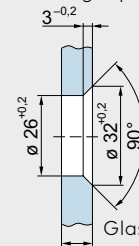

Pivoting doors set 1

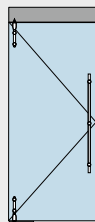

Construction 1 (1 set)

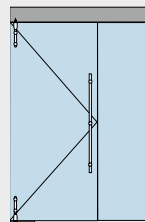

Construction 2 (1 set)

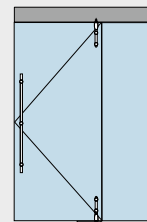

Construction 3 (1 set)

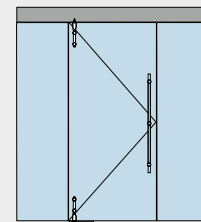

Construction 4 (1 set)

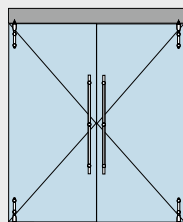

Construction 5 (2 sets)

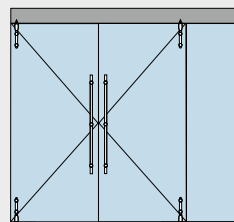

Construction 6 (2 sets)

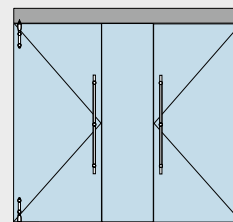

Construction 7 (2 sets)

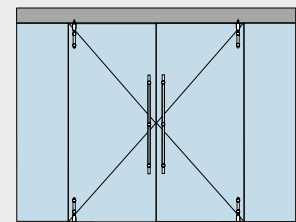

Construction 8 (2 sets)

Pivoting doors with overpanel and sidelight set 3

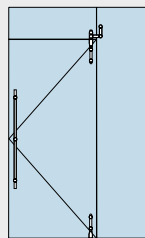

Construction 13 (1 set)

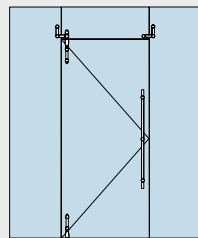

Construction 15 (1 set)

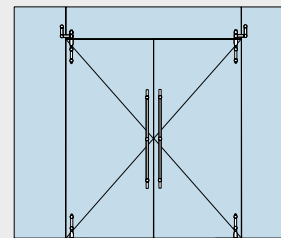

Construction 23 (2 sets)

Set 1

Pivoting door MANET Compact without overpanel for 10 – 12 mm glass

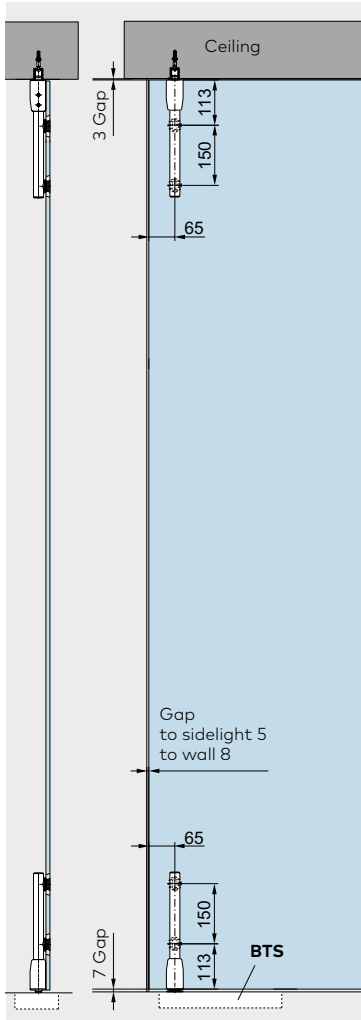

Door weight 80 kg
 Door height max. 2,500 mm
 Door width max. 1,200 mm
 TSG 10/12 mm glass thickness

	Product description	Art. No.
	Set 1 with pivot rod pair short type	
	Set 1 with single-point fixings countersunk consisting of: pivot rod pair top/bottom, short type	29.910
	including: 4 single-point fixings for pivot rods 1 pivot fitting top, 1 PT 25 pin, 15 mm Ø, with plug 1 pivot fitting bottom for BTS/floor pivot	

Accessory options for Set 1

Pull handles	Length	Art. No.
Pull handles	350	29.268
(single-point fixing countersunk)	720	29.271
	1,240	29.274
	1,760	29.277
Pair of pull handles	350	21.267
	720	21.270
	1,240	21.273
	1,760	21.276
Lock		
Corner lock		21.448
Corner lock with rose on one lock side		21.449
Profile cylinder for corner lock 21.448/449		14.206
Eccentric bushing for corner lock 21.448/449		05.194
Further accessories		
Stop for pivoting door with ceiling mounting		21.334
Ceiling fixing (bearing function)		29.337
Floor pivot bearing		01.106
Assembling tool for MANET single-point fixings		21.134

For the requisite glass preparation please see pages 146 – 147

Set 3

Pivoting door MANET Compact with overpanel for 10 – 12 mm glass

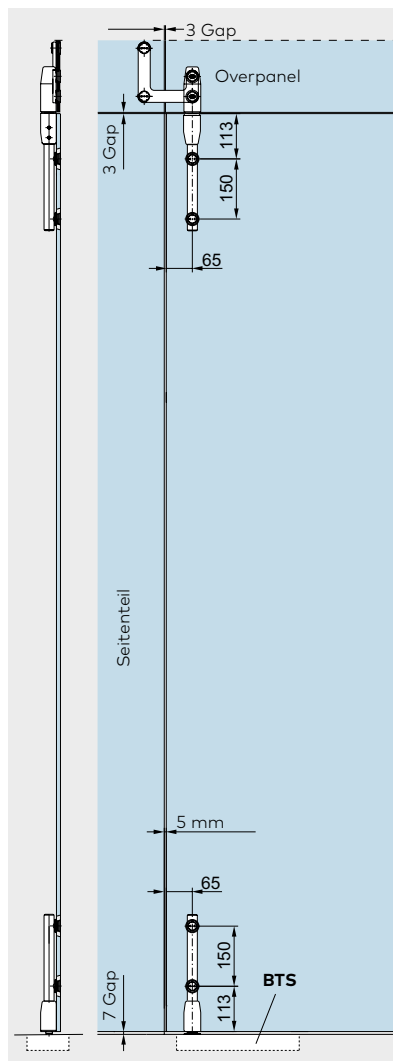

Door weight 80 kg
 Door height max. 2,500 mm
 Door width max. 1,200 mm
 TSG 10/12 mm glass thickness

Product description	Art. No.
Set 3 with pivot rod pair short type	
Set 3 with single-point fixings coutertsunk consisting of: pivot rod pair top/bottom, short type	29.914
einschließlich: 4 single-point fixings for pivot rods, 1 pivot fitting top, 1 overpanel-sidelight connector with pivot bearing location, 1 pivot fitting bottom for BTS/floor pivot	

Accessory options for Set 3

Pull handles	Length	Art. No.
Pull handles (single-point fixing countersunk)	350	29.268
	720	29.271
	1,240	29.274
	1,760	29.277
Pair of pull handles	350	21.267
	720	21.270
	1,240	21.273
	1,760	21.276
Ceiling fixing (bearing function)		29.337
Stop at overpanel, (inside/outside) for 10/12 mm glass		29.335
Lock		
Corner lock		21.448
Corner lock with rose on one lock side		21.449
Profile cylinder for corner lock 21.448/449		14.206
Eccentric bushing for corner lock 21.448/449		05.194
Further accessories		
Overpanel-sidelight connector for 10/12 mm glass		29.320
Floor pivot bearing		01.106
Assembling tool for MANET single-point fixings		21.134

For the requisite glass preparation please see pages 146 – 147

Space for your notes

Content

MANET Concept

140	General information
141	Components
146	Glass preparation
188	Accessories
212	Safety-related information

All elements up to and including the pull handles are available in an elegant stainless steel finish. All the components are manufactured from the steel grade 1.4305 (approx. AISI 303) for normal interior applications.

Note: The products detailed in this brochure are exclusively intended for glass assemblies that do not require separate building regulations approval.



MANET Concept

Pivoting door system

MANET pivoting doors can be installed in both glass partitions and masonry openings. They come as both single and double-action swing doors. All the single-point fixings are designed for clip-on covers for easier installation. Other components include the bottom pivot bearing, top pivot fittings with bearing spigot or eccentric bushing and also overpanel/ sidelight connectors.

As a result, there are almost unlimited possibilities for inte-grating frameless swing doors both in masonry openings – with or without overpanels and sidelights – and in glass partition constructions retained by single-point fixings. Whether with a full-length pivot rod or a pair of shorter pivot rods, the top bearing socket is located in the fitting on the door leaf. This means that connection to the ceiling, lintel or transom can now be provided in the form of the standard PT25 top pivot spigot from the dormakaba range. The door assemblies can be equipped with floor springs such as the dormakaba BTS 75V or BTS 84, and corner locks are naturally also available.

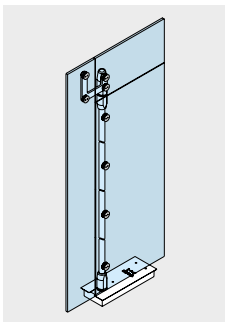

Pivot bearing with full-length pivot rod,
max. door panel height 3,000 mm
max. door panel width 1,200 mm
max. door panel weight 100 kg

From a door panel height of 2,700 mm a fifth single-point fixing is recommended.

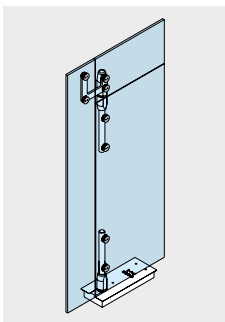

Pivot bearing with pivot rod pair short type,
max. door panel height 2,500 mm
max. door panel width 1,200 mm
max. door panel weight 80 kg

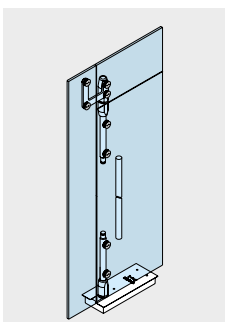

Pivot bearing with pivot rod pair short type with intermediate tube,
max. door panel height 2,500 mm
max. door panel width 1,200 mm
max. door panel weight 80 kg

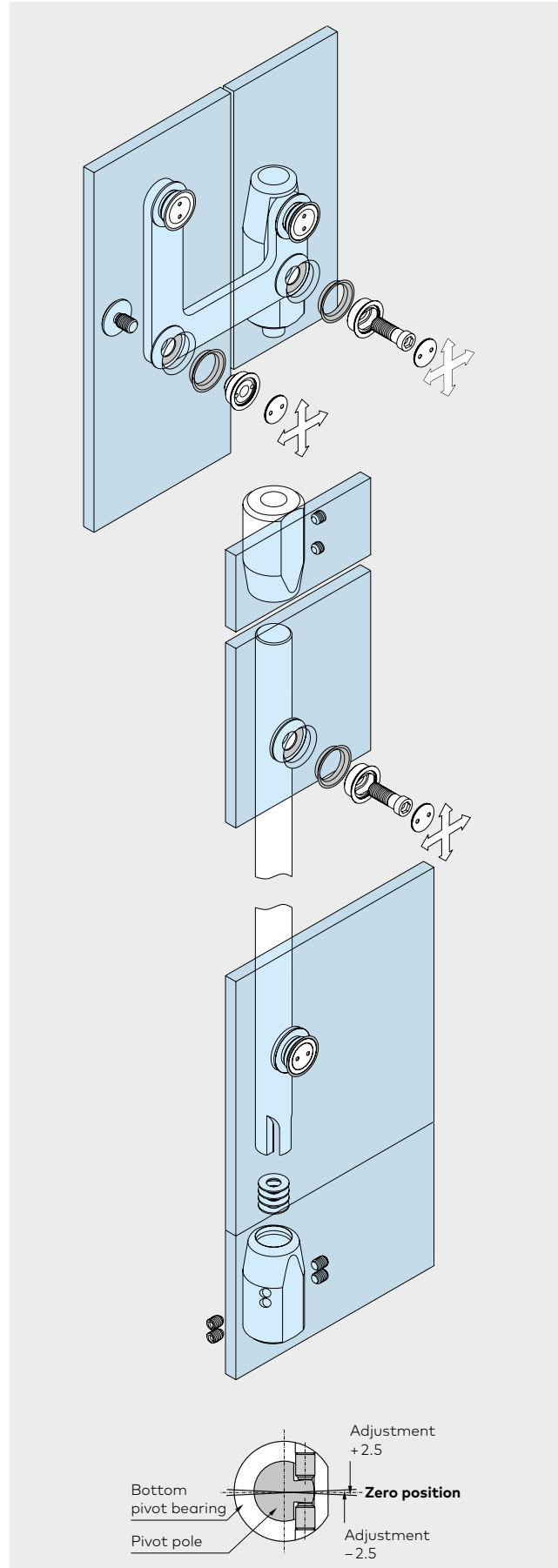

Components for pivoting door system

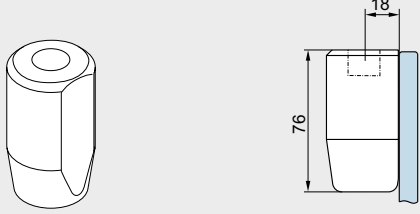
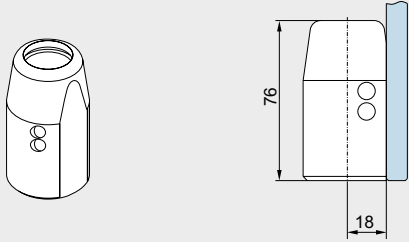
	Product description	Glass thickness	Art. No.
	<p>Pivot bearing for overpanel and ceiling connection</p> <p>AISI 316L</p>		<p>21.310</p>
	<p>Pivot bearing for BTS (max. 4 EN) / floor pivot</p> <p>AISI 316L</p>		<p>29.545</p>

Components for pivoting door system

	Product description	Glass thickness	Art. No.
	Pivot rod, drilled, fixed length		29.551
	Single-point fixing, countersunk, fixed (1)	10, 12 mm	29.460
	AISI 316L clamping disc, fixed (1)	13.5–15.5 mm	
	AISI 316L Single-point fixing, countersunk, centering (2)	10, 12 mm	29.462
	AISI 316L clamping disc, centering (2)	13.5–15.5 mm	
From a door panel height of 2,700 mm a fifth single-point fixing is recommended.	10, 12 mm		

Glass fixing

	Product description	Glass thickness	Art. No.	Art.-Nr.
	<p>Overpanel / sidelight connection countersunk clamping disc</p>	<p>10, 12 mm</p>	<p>29.320</p>	
	<p>PT 25 pin for ceiling connection,</p>			<p>01.115</p>

Accessories

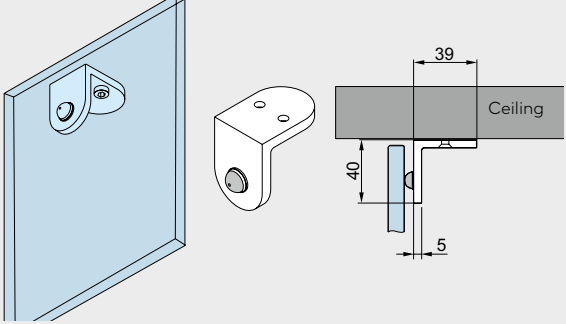
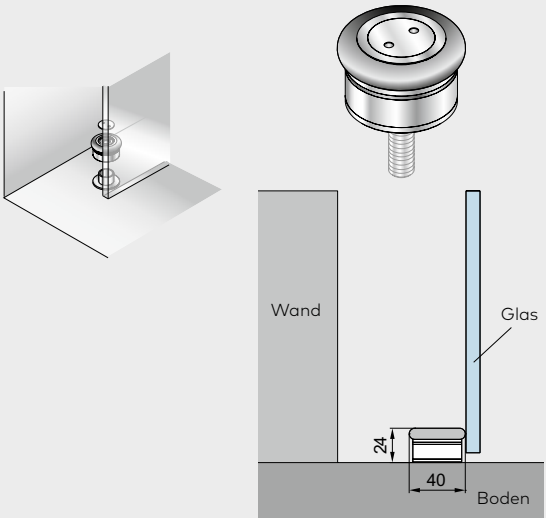
	Product description	Glass thickness	Art. No.
	<p>Stop for pivoting door with ceiling mounting</p>		<p>21.334</p>
	<p>Stop for pivoting door floor mounting</p>		<p>29.950</p>

	Product description	Glass thickness	Art. No.
	Corner lock	8-12 mm	21.448
	Corner lock with profile cylinder rose on inside	8-12 mm	21.449
	Dead lock for KABA with rose on inside	8-12 mm	
	Profile cylinder for corner lock		14.206
	Eccentric bushing for corner lock		05.194
	Bushing, plastics		00.110
	Strike plate		05.190

Glass preparation for pivoting door system

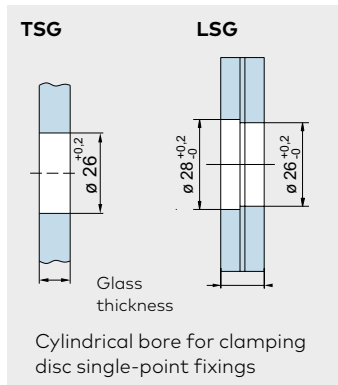
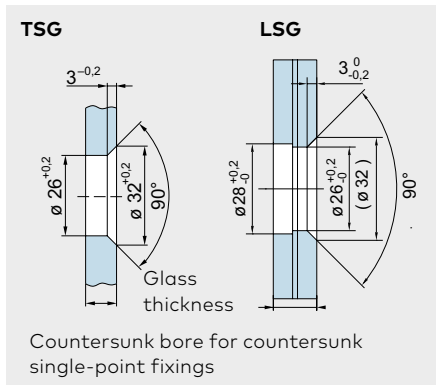

The gap and distance dimensions recommended by dormakaba are indicated in the adjacent table.

Glass thickness mm	Connection	X Gap	Y
10/12	Sidelight	5	65
	Wall	8	
13.5–15.5	Sidelight	8	62
	Wall	11	

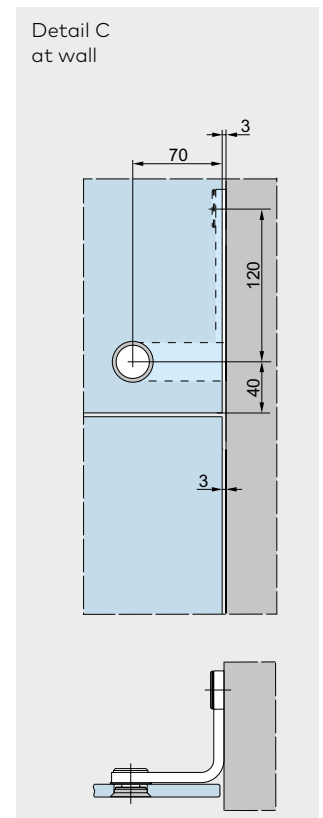
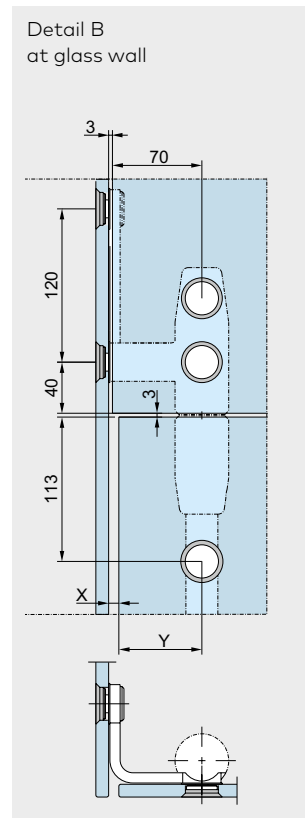
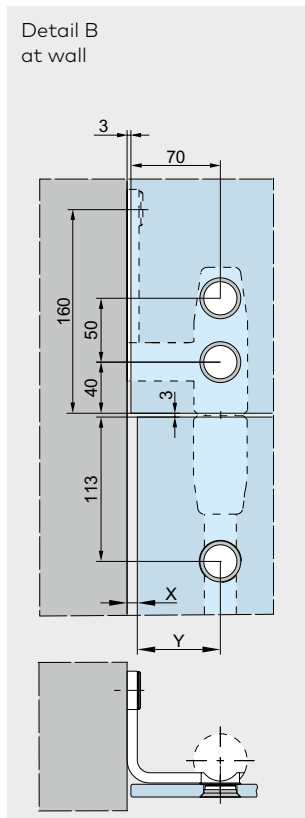
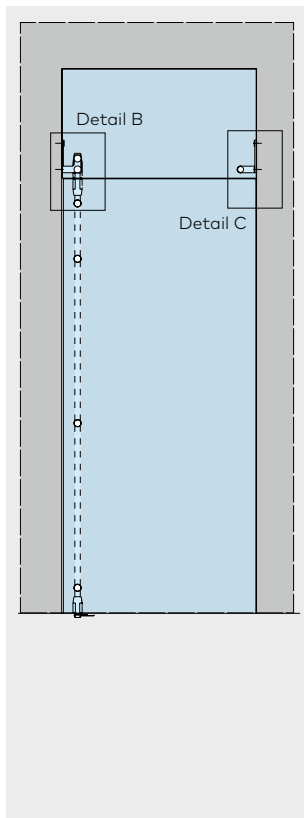
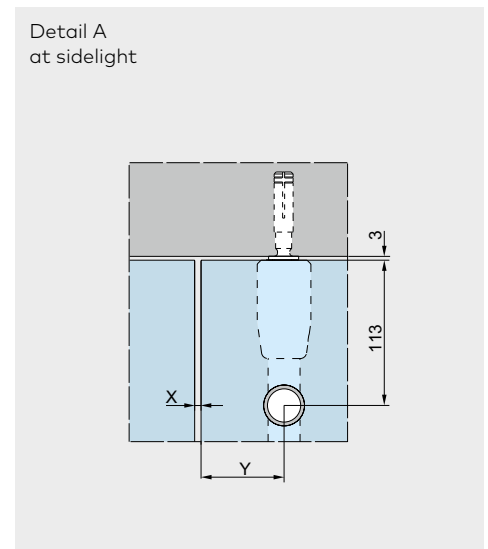
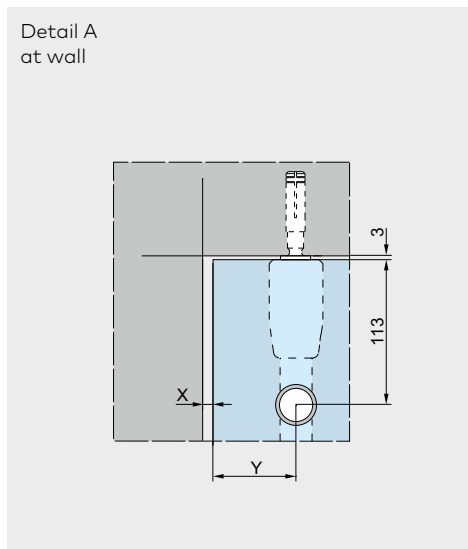
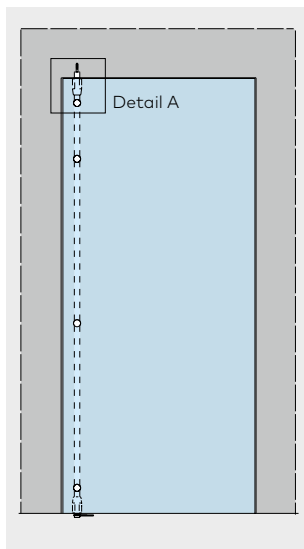

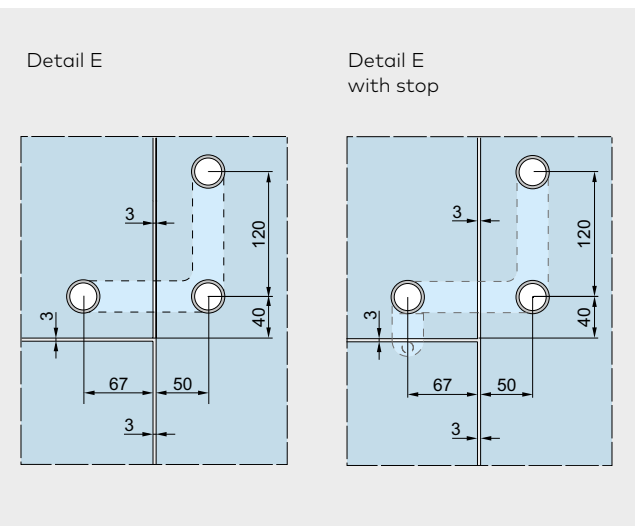
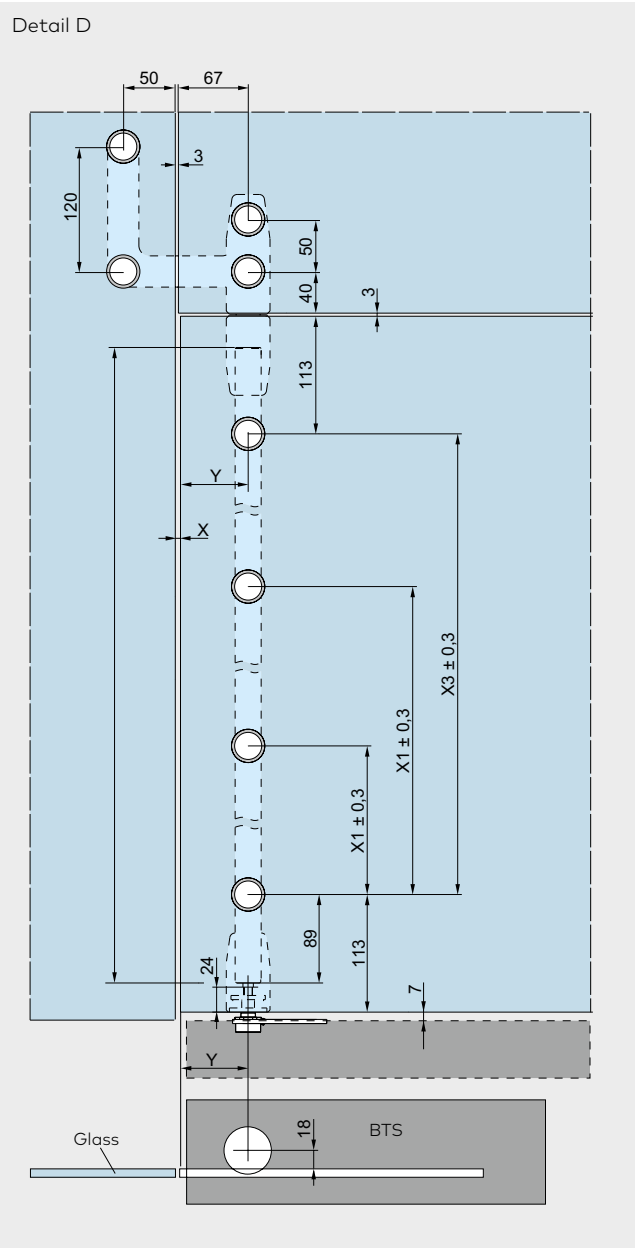
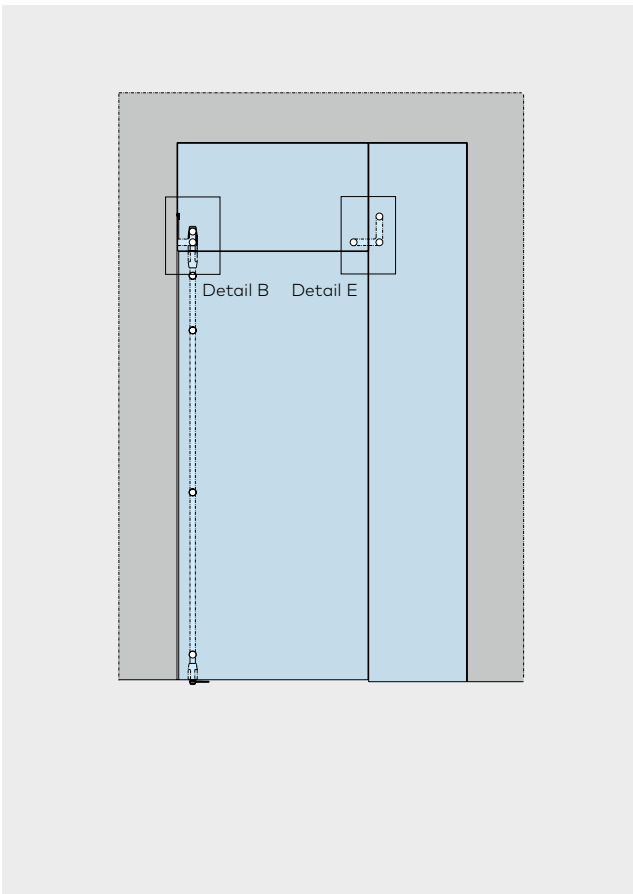
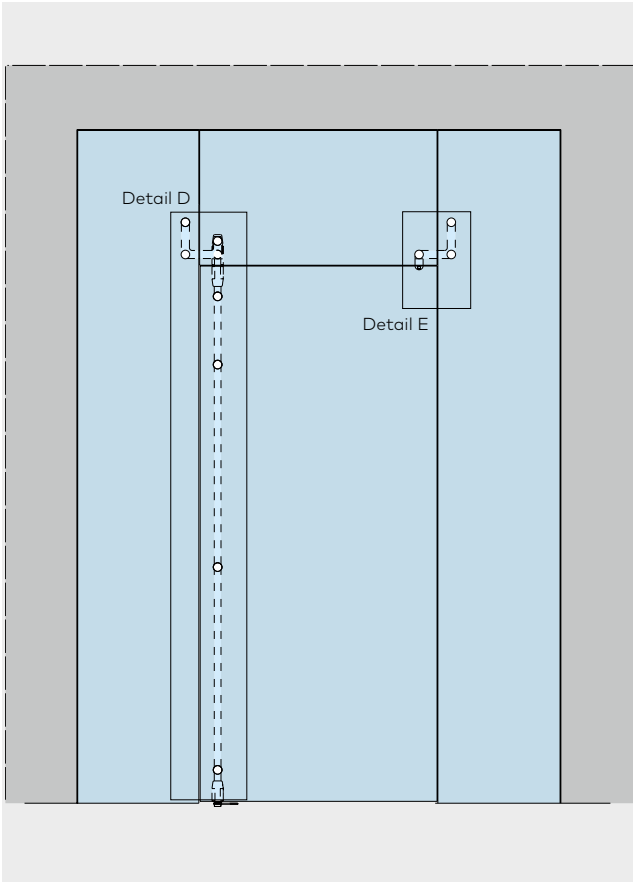

Content

MANET Concept Connection system

150 **General information**

160 **Components**

161 **Glass preparation**



**MANET Concept
Connection system**

Connection system

Glass fixing

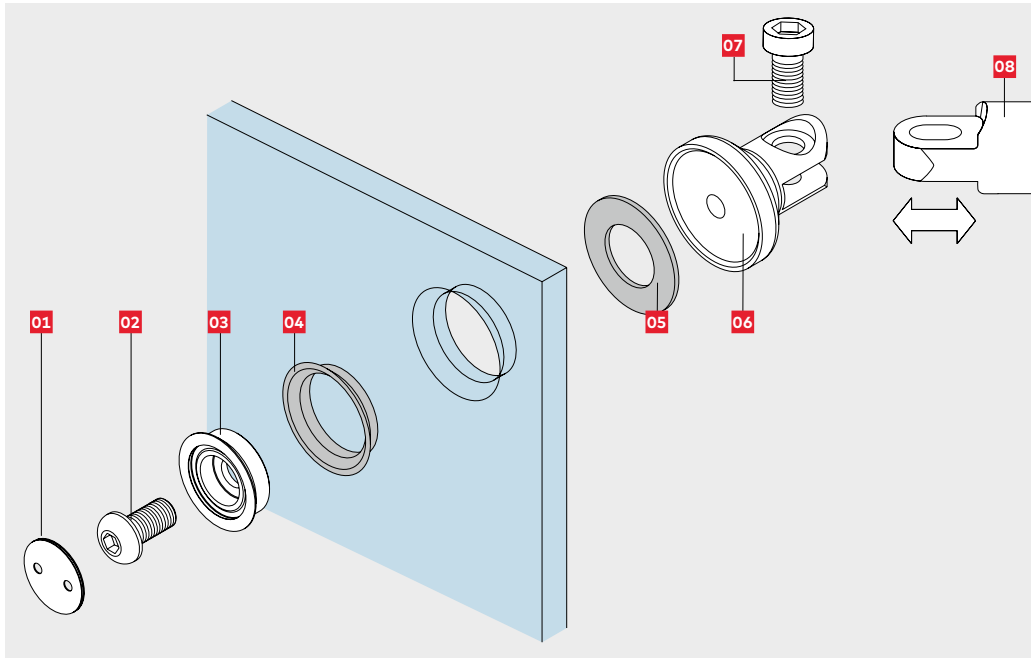

Components

- 01** Clip-on cover
- 02** Connecting bolt
- 03** Conical collar
- 04** Conical sleeve
- 05** Gasket
- 06** Pivoting clamp
- 07** Connecting bolt
- 08** Connecting rod to suit length

Connection ceiling / floor

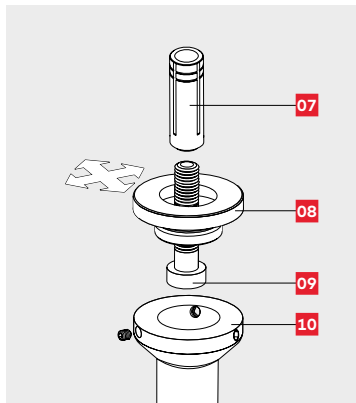
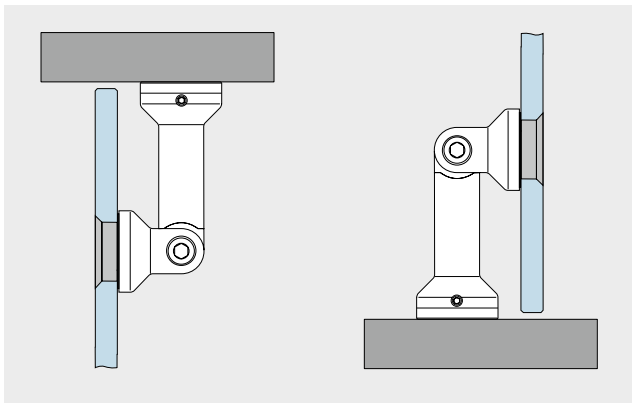

Components

- 07** Wallplug on site
- 08** Mounting plate, 2-dimensional adjustable
- 09** Threaded rod M8
- 10** Column

Alternative connection ceiling

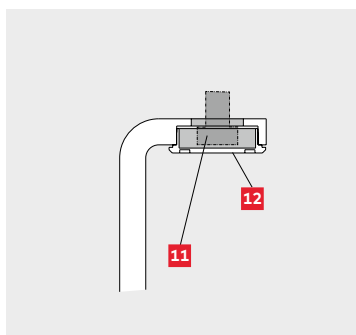
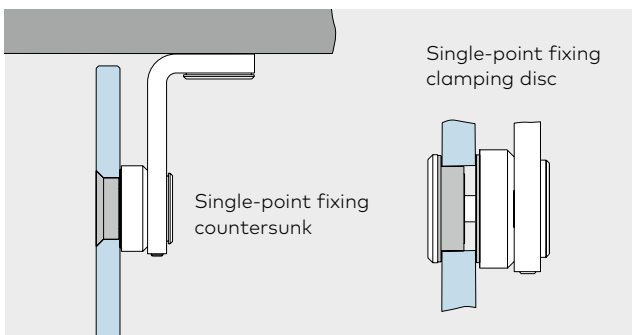

Components

- 11** Threaded rod M8 DIN 7984 M10 x..., or oval-head wood screw DIN 7996 M8 x...
- 12** Clip-on cover

Complete fitting

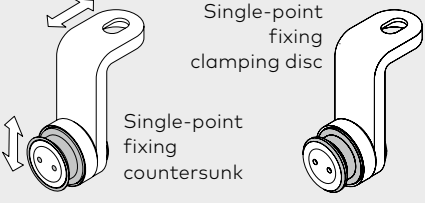
	Product description	Glass thickness	Art. No.
 <p data-bbox="392 443 488 495">Glass thickness</p> <p data-bbox="164 600 280 622">Glass/Floor</p>	<p>Complete fitting Corner connector 90° (only bearing function)</p>	<p>8 – 12 mm</p>	<p>29.145</p>
 <p data-bbox="376 685 512 763">Single-point fixing clamping disc</p> <p data-bbox="304 797 432 875">Single-point fixing countersunk</p> <p data-bbox="164 913 491 936">Height adjustment via grub screw</p>	<p>Complete fitting Ceiling fixing (bearing function)</p> <p data-bbox="691 752 831 853">countersunk AISI 316L clamping disc AISI 316L</p>	<p>8 – 12 mm</p>	<p>29.337 29.338</p>

Glass preparation connection system

For TSG and LSG from TSG.

Recommended centers for fixed glazing element

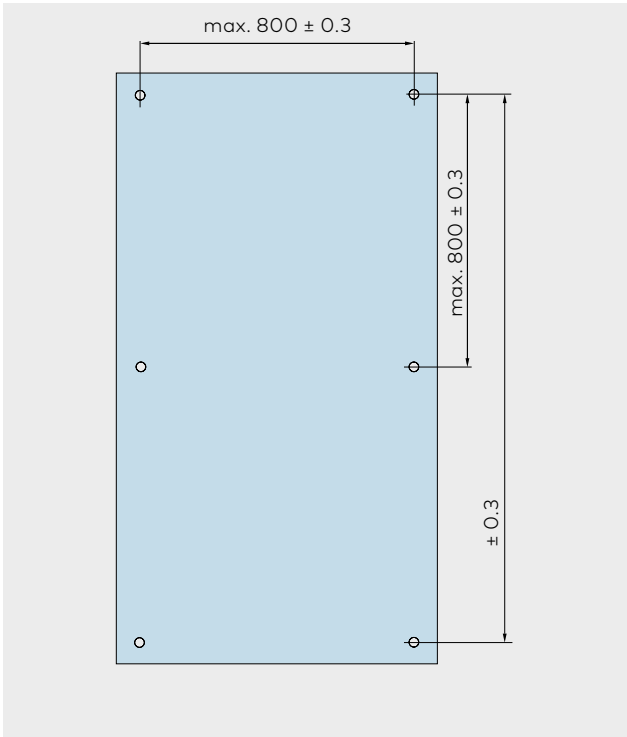

Countersunk bore for countersunk single-point fixings

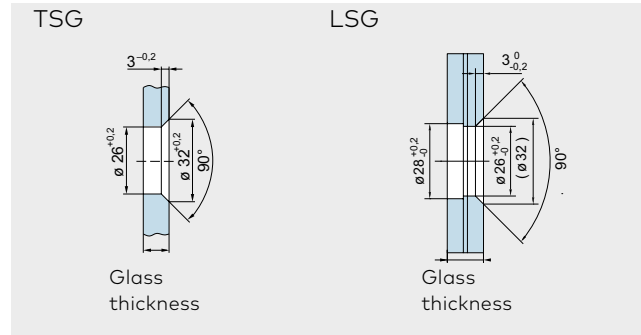

Cylindrical bore for clamping disc single-point fixings

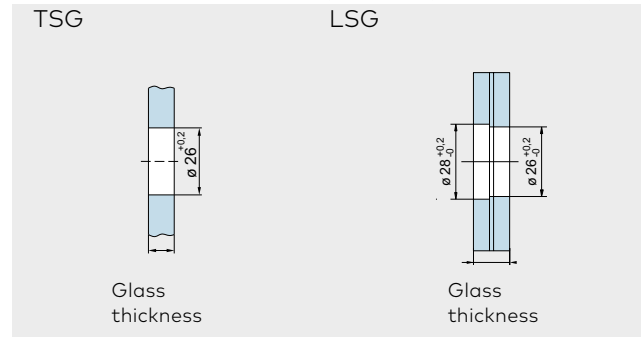

Corner connector glass / ceiling

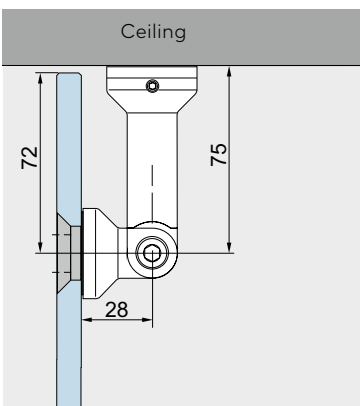

Corner connector glass / floor

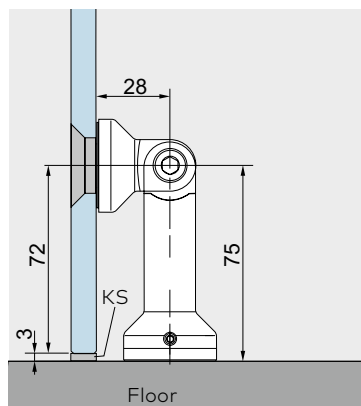

Ceiling fixing (bearing)

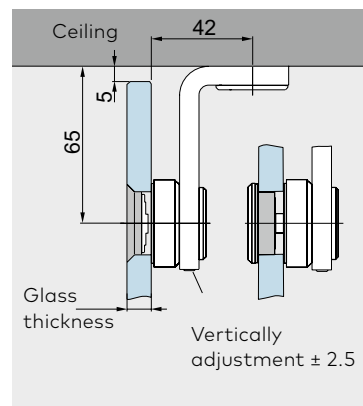

Note: Ensure compliance with minimum glass/bore clearances as per glass manufacturer recommendations. Glass preparation with a tolerance of max. ± 0.3 mm is recommended.

Content

SG

156	General information
156	Components
170	Glass preparation
188	Accessories
212	Safety-related information



SG

A range of locks for all requirements

It doesn't matter what sort of glass door needs securing, what function it has to fulfill, or the type of fittings specified – there will be a lock in the SG range which will provide the shape, the function and the finish which you require.

Simple glass preparation, firm fixing

dormakaba has an intimate knowledge of the special properties of glass as a building material. This has led to the design of locks requiring only simple cut-outs or holes in the glass. Carefully considered and positive measures have been taken to create the maximum clamping surface with optimum clamping efficiency.

Reliability built in

Quality materials and thorough workmanship mean that SG locks have the features necessary to meet the most demanding of specifications. Many satisfied customers will testify this. For safety reasons set lock case always on inside.

Short delivery times

All the common patterns and types are available ex-stock (factory). Specials will be prepared promptly.

UNIVERSAL top, bottom, centre locks and strike boxes with glass cut-outs

Complete, for 10 mm glass thickness

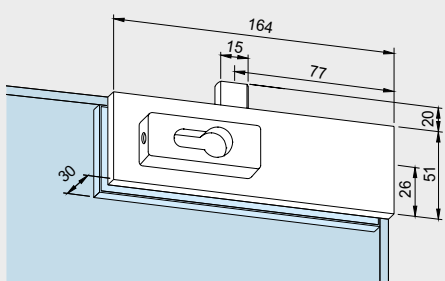
	Product description	Glass thickness	Art. No.
	<p>US 10 corner lock, prepared for Europrofile cylinder, single throw, bolt projection 20 mm, with security rosettes on both sides, 14 mm thick. Suitable gaskets have to be used for systems with an 8 or 12 mm glass thickness. These are available on page 196.</p> <p>Lock insert:</p> <ul style="list-style-type: none"> • high corrosion resistance according to EN 1670 • with regard to type-test according to DIN 18251, class 3* <p>Not illustrated: prepared for KABA</p>	10 mm	03.206
	For half profile cylinder	10 mm	03.340
	left hand top/right hand bottom	10 mm	03.288 not illustr.
	Weight in kg/m: Aluminum 0.942 Brass 1.061 Stainless steel 1.053		
	left hand bottom/right hand top	10 mm	03.287 not illustr.

*Extract from DIN 18251, class 3: Type-test with 50,000 locking bolt operating cycles. Furthermore the lock was tested successfully by a neutral testing institute with 500,000 latch and 100,000 locking bolt operating cycles.

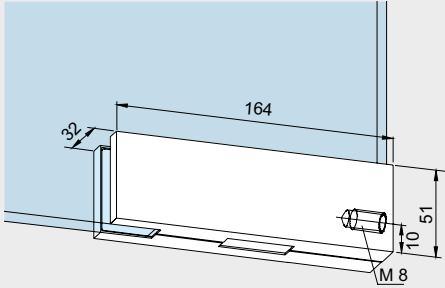
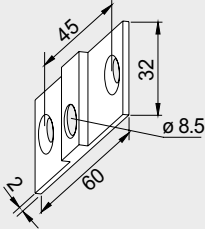
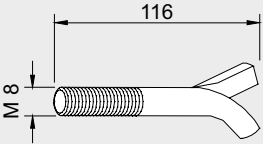
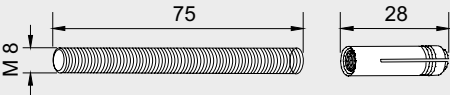
	Product description	Glass thickness	Art. No.
	<p>GK 30 single overpanel strike box to suit US 10 corner lock</p> <p>Weight in kg: Aluminum 0.418 Stainless steel 0.536</p>	10 mm	03.230
	<p>Fixing plate for overpanel strike box GK 30 UNIVERSAL</p> <p>Weight in kg: Aluminum 0.016 Brass 0.038</p> <p>Stainless steel not available, satin chrome on brass supplied.</p>		03.128
	<p>Wall anchor with thread M 8 for overpanel patch UNIVERSAL</p> <p>Weight in kg: 0.040</p>		01.133
	<p>Threaded rod M 8 with plug for overpanel patch UNIVERSAL</p> <p>Weight in kg: 0.032</p>		01.134

* Left / right hand (illustration shows left hand) are determined by view from hanging side.

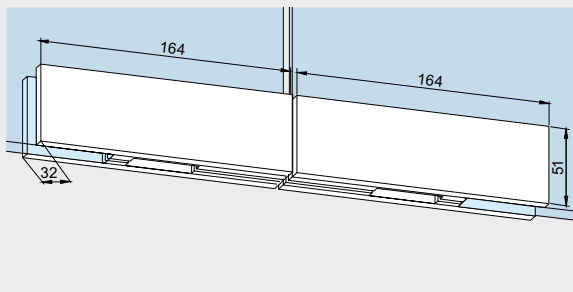
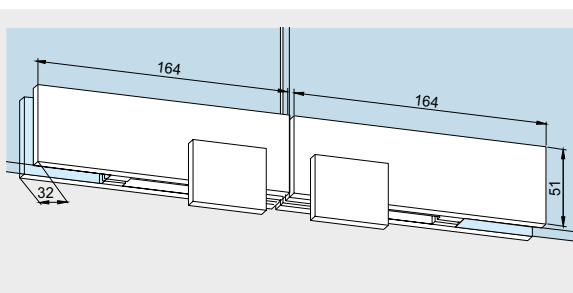
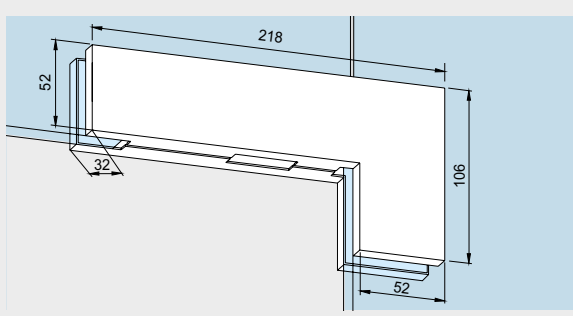
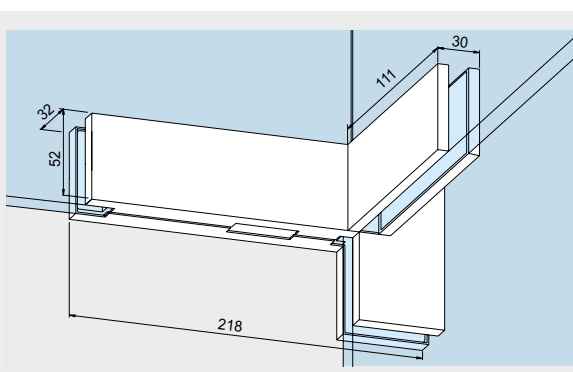
	Product description	Glass thickness	Art. No.
	<p>GK 20 double overpanel strike box to suit US 10 corner locks, consisting of two GK 30 with threaded connecting bolt</p> <p>Weight in kg: Aluminum 0.866 Brass 1.154 Satin stainless steel (700) 1.200</p> <p>Suitable for glass thicknesses up to max. 12 mm. If thicker glass is required, please talk first to our Applications Engineering people.</p>	10 mm	03.245
	<p>GK 20 with stop</p> <p>Weight in kg: Aluminum 0.926 Brass 1.234 Satin stainless steel (700) 1.192</p> <p>Suitable for glass thicknesses up to max. 12 mm. If thicker glass is required, please talk first to our Applications Engineering people.</p>		03.247
	<p>GK 40 corner overpanel strike box to suit US 10 corner lock</p> <p>Weight in kg: Aluminum 0.709 Brass 1.035 Stainless steel 1.010</p>		03.250
	<p>GK 41 strike box for PT 41, with fin fitting</p> <p>Weight in kg: Aluminum 0.906 Stainless steel 1.270</p>		*03.194/ 03.193

* Left / right hand (illustration shows left hand) are determined by view from hanging side.

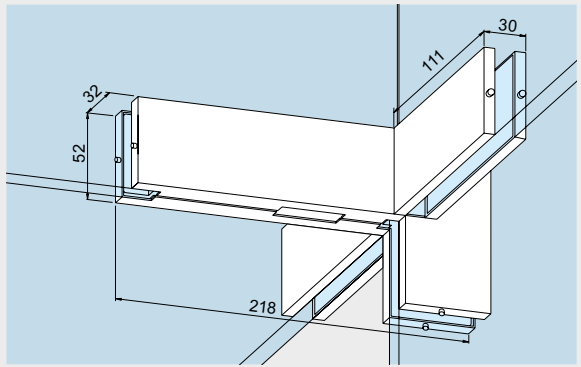
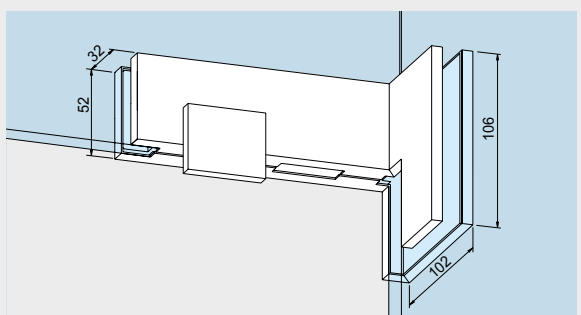
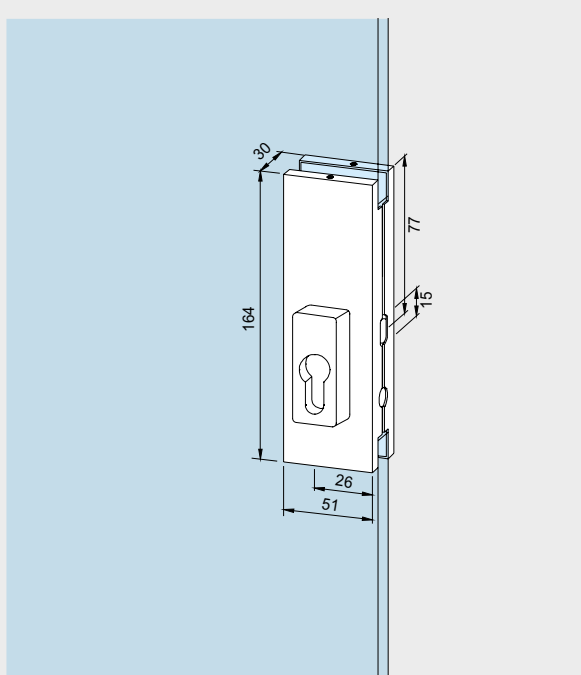
	Product description	Glass thickness	Art. No.
	<p>GK 41 strike box with fin fitting on both sides</p> <p>Weight in kg: Aluminum 1.103 Stainless steel 1.411</p>		03.195
	<p>GK 42 strike box, angle 90°, for PT 42, with stop inside</p> <p>Weight in kg: Aluminum 0.910 Stainless steel 1.306</p> <p>Not illustrated: GK 42, angle 135°</p>		*03.274/ 03.275
	<p>US 20 centre lock, prepared for Europrofile cylinder, single throw, bolt projection 20 mm, with security rosettes 14 mm thick.</p> <p>Weight in kg: Aluminum 0.942 Brass 1.061 Stainless steel 1.053</p> <p>Lock insert:</p> <ul style="list-style-type: none"> • high corrosion resistance according to EN 1670, class 4 • with regard to type-test according to DIN 18251, class 3** <p>Weight in kg: Aluminum 0.805 Stainless steel 0.925</p> <p>prepared for KABA</p> <p>Prepared for one-sided Europrofile cylinder (see drawing 03.215)</p>	10 mm	03.215
			03.345 not illustr.
			*03.290/ 03.289

* Left / right hand (illustration shows left hand) are determined by view from hanging side.
 ** Extract from DIN 18251, class 3: Type-test with 50,000 locking bolt operating cycles. Furthermore the lock was tested successfully by a neutral testing institute with 500,000 latch and 100,000 locking bolt operating cycles.

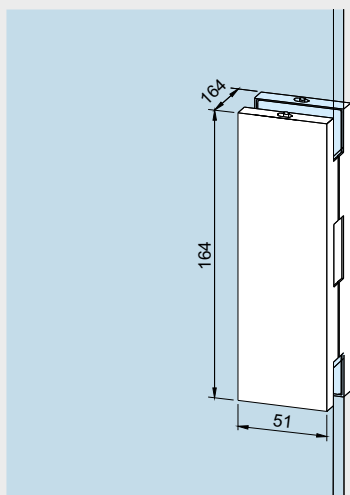
	Product description	Glass thickness	Art. No.
	<p>GK 50 strike box to suit US 20 centre lock</p> <p>Weight in kg: Aluminum 0.602 Brass 0.730 Stainless steel 0.727</p>	<p>10 mm</p>	<p>03.224</p>

Corner (OR centre) locks and strike boxes with drilled holes glass preparation

Complete for 8, 10 and 12 mm glass thickness

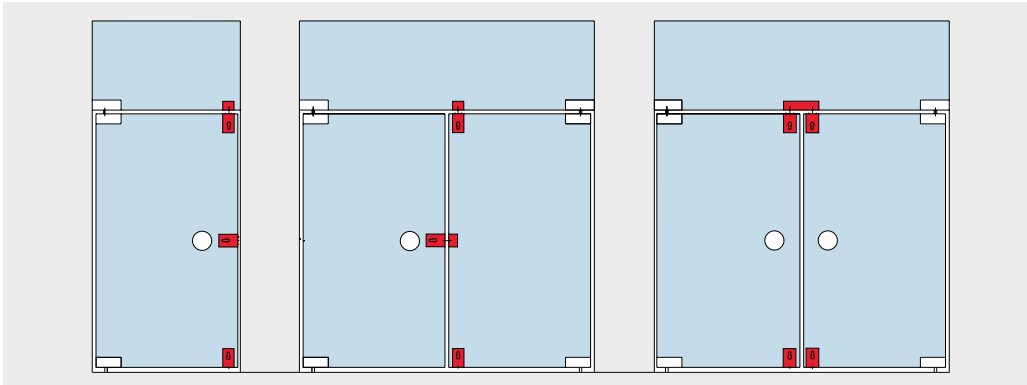

		Product description	Art. No.
	<p>Corner lock, for vertical or horizontal fixing, double throw, bolt projection 20 mm, hardened oval bolt, prepared for Europrofile cylinder</p> <p>Weight in kg: Aluminum 0.849 Brass 1.033</p>	05.100	
	<p>prepared for KABA</p> <p>Weight in kg: Aluminum 0.842 Brass 1.020</p>	05.105 not illustr.	
	<p>Prepared for one-sided Europrofile cylinder, lockable from inside</p> <p>Weight in kg: Aluminum 0.858 Brass 1.038</p>	05.116 not illustr.	
	<p>Corner lock, prepared for Europrofile cylinder, rose inside</p> <p>Weight in kg: Aluminum 0.924 Brass 1.236</p>	05.118	

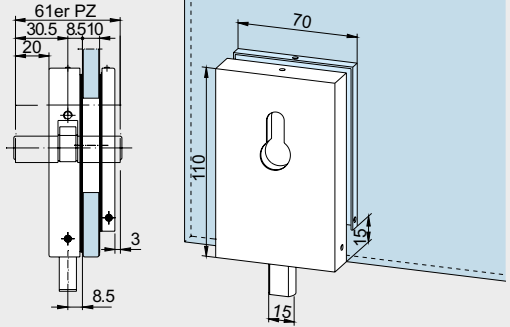
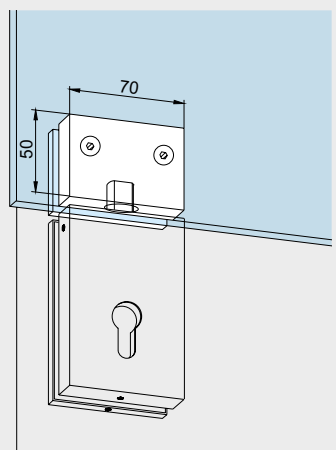
	Product description	Art. No.
	<p>Corner lock, for vertical fixing, double throw, bolt projection 20 mm, hardened oval bolt, counterplate shortened to give 15 mm free glass edge, prepared for Europrofile cylinder</p> <p>Weight in kg: Aluminum 0.807</p> <p>Prepared for one-sided Europrofile cylinder, lockable from inside</p> <p>Weight in kg: Aluminum 0.818 Brass 0.984</p> <p>Prepared for Europrofile cylinder, rose inside</p> <p>Weight in kg: Aluminum 0.882 Brass 1.184</p>	<p>05.103</p> <p>05.117 not illustr.</p> <p>05.119 not illustr.</p>
	<p>Strike box to suit corner lock (05.100, 05.105, 05.116), for single und 2- door without stop</p> <p>Weight in kg: Aluminum 0.260 Brass 0.765</p> <p>with stop for Art. No. 05.103, 05.117, 05.119</p> <p>Weight in kg: Aluminum 0.264 Brass 0.760</p>	<p>05.108</p> <p>05.109 not illustr.</p>

Corner and centre locks without glass preparation

Complete, for 10 and 12 mm glass thickness

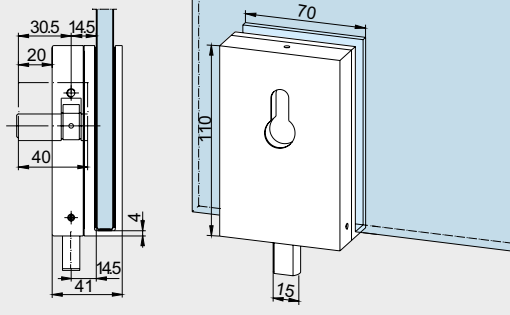
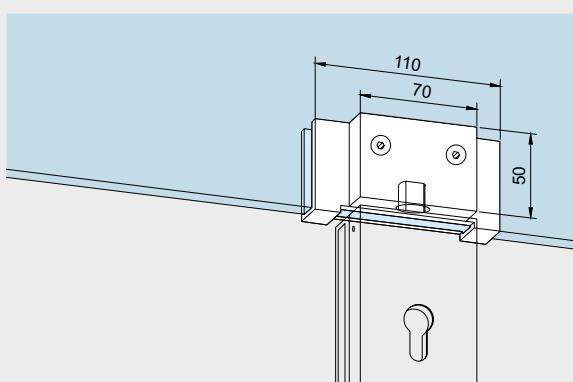
	Product description	Glass thickness	Art. No.
	<p>Slide over corner lock for single- and double-action doors for retrofitting, double throw, bolt projection 20 mm, hardened oval bolt, prepared for Europrofile cylinder</p> <p>Special model for 8 mm glass also available.</p> <p>Weight in kg: Aluminum 0.740</p>	<p>10 mm</p> <p>12 mm</p>	<p>05.106</p> <p>05.130</p>
	<p>prepared for KABA</p> <p>Weight in kg: Aluminum 0.735</p>	<p>10 mm</p>	<p>05.107</p>
	<p>Slide over strike box for slide over corner lock for single door</p> <p>Weight in kg: Aluminum 0.341</p>		
	<p>for Art. No. 05.106/05.107</p> <p>for Art. No. 05.130/05.131</p>	<p>10 mm</p> <p>12 mm</p>	<p>05.112</p> <p>05.132</p>

Centre locks and strike boxes

Complete, for 10 mm glass thickness

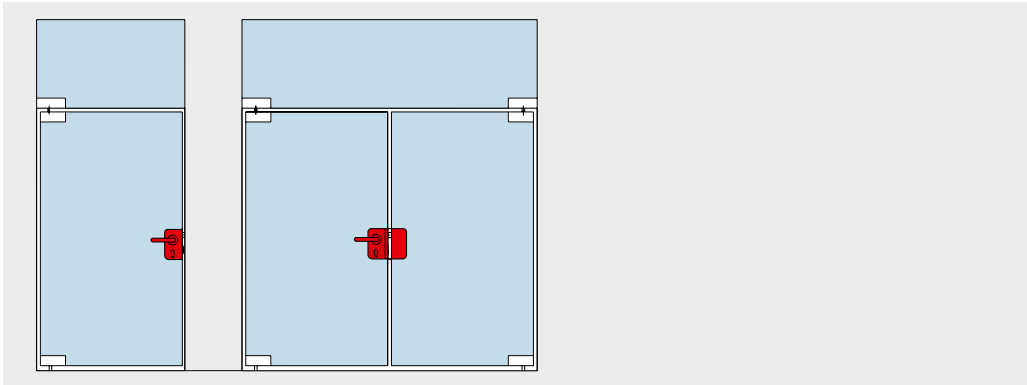

Centre locks and strike boxes
with drilled holes glass preparation

	Product description	Art. No.
	<p>Centre lock for single-action door (with free glass edge), prepared for Europrofile cylinder, double throw</p> <p>Weight in kg: Aluminum 1.060</p>	<p>*11.220/11.221</p>

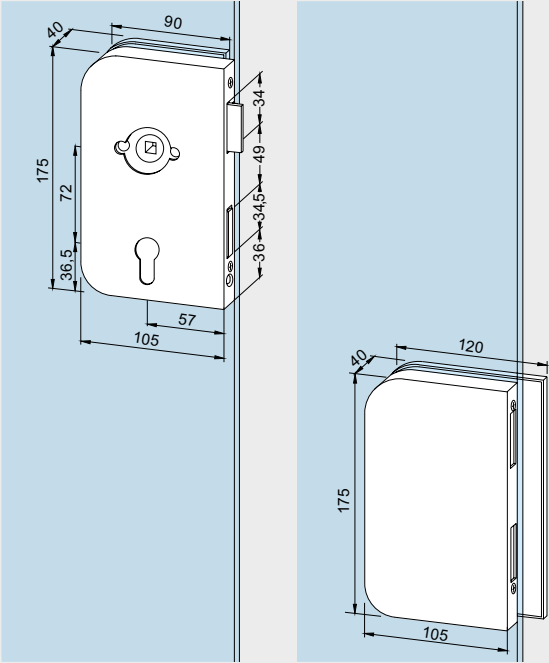
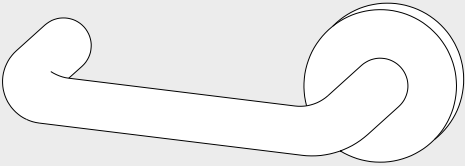
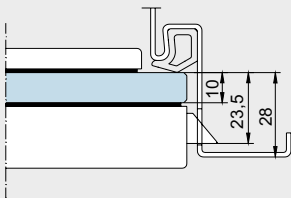
	Product description	Art. No.
	<p>Centre lock for single-action door (with free glass edge), with both latch and lock bolt, prepared for lever on round rose inside, smooth blanking plate outside, prepared for Europrofile cylinder, double throw</p> <p>Weight in kg: Aluminum 1.175</p> <p>Strike box to suit centre locks for: Art. No. 11.224, 11.225 Art. No. 11.220, 11.221</p> <p>Weight in kg: Aluminum 0.945</p>	<p>*11.224/11.225</p> <p>*11.203/12.207</p>
	<p>Lever handle, for inside to suit centre locks for: Art. No. 11.224, 11.225, Art. No. 11.254, 11.255</p> <p>Weight in kg: Aluminum 0.195</p>	<p>11.226</p>
	<p>If used on glass doors in rebated frames and for 10 mm glass thickness, a minimum of 26–28 mm frame depth is needed.</p> <p><small>* Left / right hand (illustration shows left hand) are determined by view from hanging side.</small></p>	

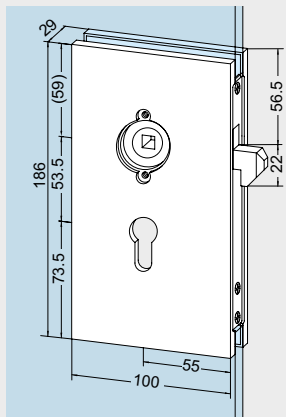
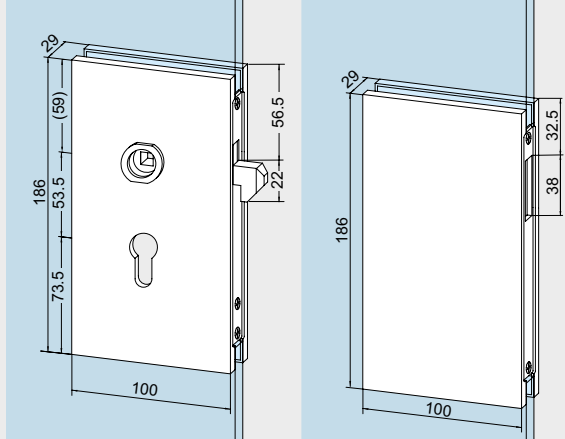
	Product description	Art. No.
	<p>Hook lock for sliding doors, nightlatch function, suitable for aluminum lever handles with round roses (10.307), prepared for Euro-profile cylinder, left hand and right hand, with lock keeper plate</p> <p>Weight in kg: Aluminum 1.325</p>	<p>05.200</p>
	<p>Suitable for lever handles with follower</p> <p>Weight in kg: Aluminum 1.325</p> <p>Strike box to suit hook lock, (05.200, 05.202), non-handed</p> <p>Weight in kg: Aluminum 0.890</p>	<p>05.202</p> <p>05.201</p>

* Left / right hand (illustration shows left hand) are determined by view from hanging side.

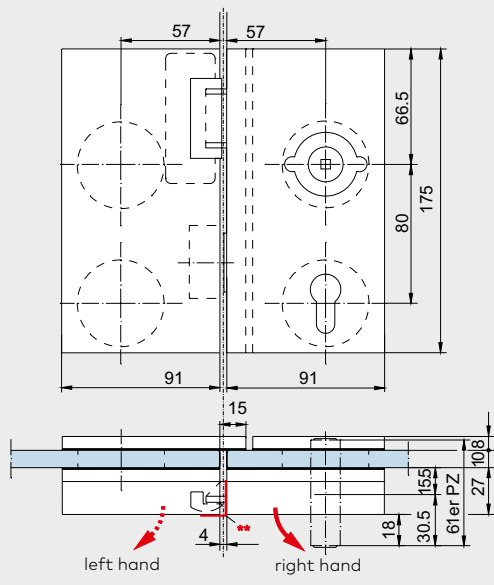
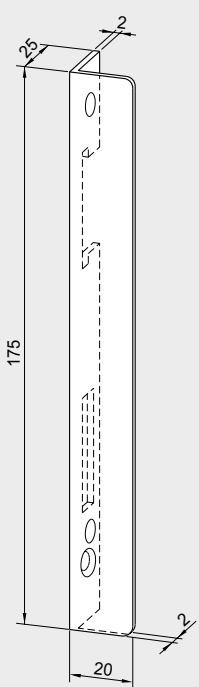
	Product description	Art. No.
	<p>Centre lock with latch and lock bolt, for inward opening single-action doors, prepared for lever on round rose inside, smooth blanking plate outside, prepared for Europrofile cylinder</p> <p>Weight in kg: Aluminum 1.090</p> <p>Suitable lever handle see page 199</p> <p>Centre lock with latch and lock bolt, for inward opening single-action doors, prepared for rose lever on both sides, prepared for Europrofile cylinder</p> <p>Weight in kg: Aluminum 1.090</p> <p>Strike box, to suit centre lock with latch and lock bolt, with electric strike release (Standard: fail secure function, 6 to 12 V -/-, with mechanical unlock. Further types on request.) (for Art. No. 05.224, 05.225)</p> <p>Weight in kg: Aluminum 0.595</p>	<p>*05.224/05.225</p> <p>11.226</p> <p>*05.228/05.229</p> <p>*05.226/05.227</p>
 <p>LH/ISO 6 door illustrated.</p>	<p>Angle bracket for centre locks (opening to outside)</p> <p>Weight in kg: 0.040</p>	<p>*05.218/05.219</p>

* Left / right hand are determined by view from hanging side.
** Angle bracket (05.218/05.219) for door opening outwards (optional)

Locks with panic function, opening to outside

for 8 and 10 mm glass thickness

Operation outside: Bolt is unlocked by turn of key, and latch is withdrawn by follower.

Operation inside: Lock can be operated by rose lever handle even when bolt is locked.

Not for emergency exit doors according to German Standard DIN EN 179 or DIN EN 1125 (corresponding modifications in preparation)

For best protection against burglary we recommend the use of the angle bracket (05.218/05.219)

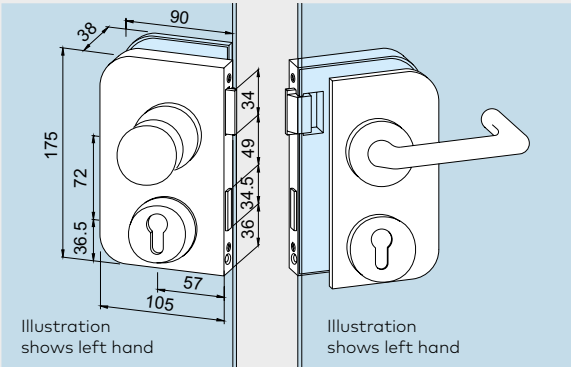
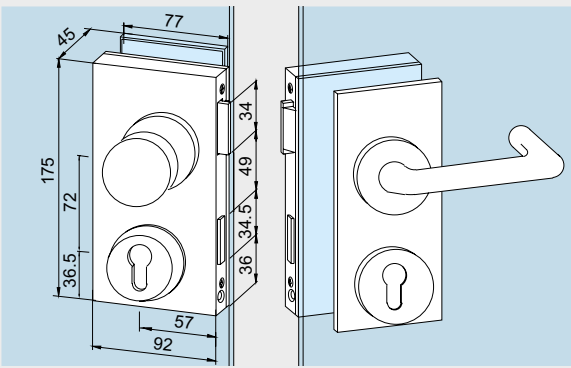
	Product description	Art. No.
 <p>Illustration shows left hand</p>	<p>Centre lock with both latch and lock bolt, rose lever on inside and fixed knob (without function) on outside. Prepared for Europrofile cylinder with roses</p> <p>Weight in kg: Aluminum 1.706</p> <p>Please use strike box 11.206/11.207.</p>	<p>*05.240/05.241</p>
 <p>Illustration shows left hand</p>	<p>For strike boxes with electric strike release</p> <p>Centre lock with both latch and lock bolt, with angled cover, for door opening outwards (not shown), rose lever on inside and fixed knob (without function) on outside. Prepared for Europrofile cylinder with roses. Lockable into strike boxes with electric strike release for Art. No. 05.226/05.227</p> <p>Weight in kg: Aluminum 2.900</p>	<p>*05.244/05.245</p>

*Left / right hand are determined by view from hanging side.

Additional exit devices for glass doors with panic function covered by approval certification can be found in the technical documentation of PHA 2000 and Exit Pad

Self-locking panic locks, opening to outside

for 8 and 10 mm glass thickness

Operation outside: Bolt is unlocked by turn of key, and latch is withdrawn by follower.

Operation inside: Lock can be operated by rose lever handle even when bolt is locked.

For emergency exit doors according to German Standard DIN EN 179.

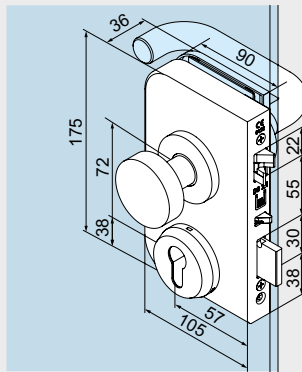
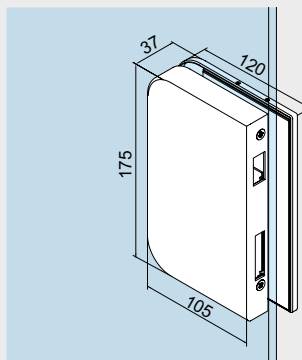
	Product description	Art. No.
	<p>Centre lock OFFICE Junior SVP 5000 with both latch, lock bolt self-locking function rose lever on inside and fixed knob (without function) on outside. Prepared for Europrofile cylinder with roses</p> <p>Weight in kg: Aluminum 1.706</p>	<p>*05.250/05.251</p>
	<p>Strike box for self-locking panic lock 05.250/05.251</p> <p>Weight in kg: Aluminum 1.486</p>	<p>*05.252/05.253</p>
<p>Please note: For frame applications with 8 mm TSG a rebate depth of min. 26 mm required. With 10 mm TSG, a fold depth of of at least 28 mm required.</p>	<p>*Left / right hand are determined by view from hanging side.</p>	

Additional exit devices for glass doors with panic function covered by approval certification can be found in the technical documentation of PHA 2000 and Exit Pad

Glass preparation locks

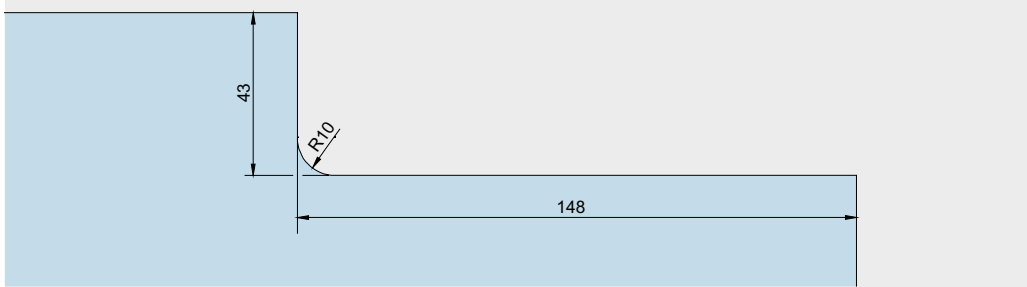

US 10

Corner locks
Art. No. 03.206,
03.285, 03.287,
03.288, 03.340

Scale 1 : 2

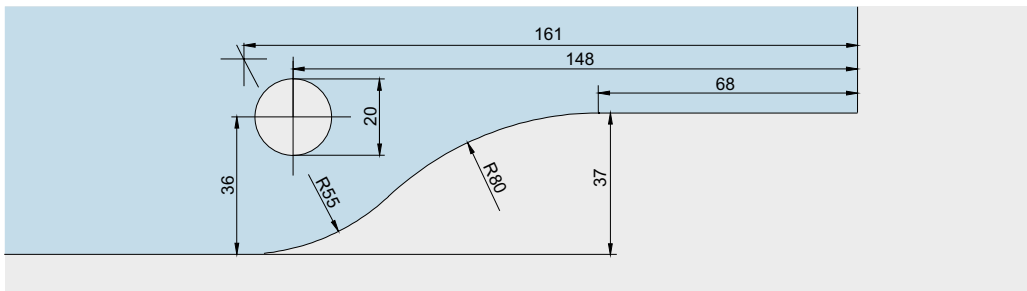

GK 30 (PT 30)

Single overpanel
strike box
Art. No. 03.230,

Scale 1 : 2

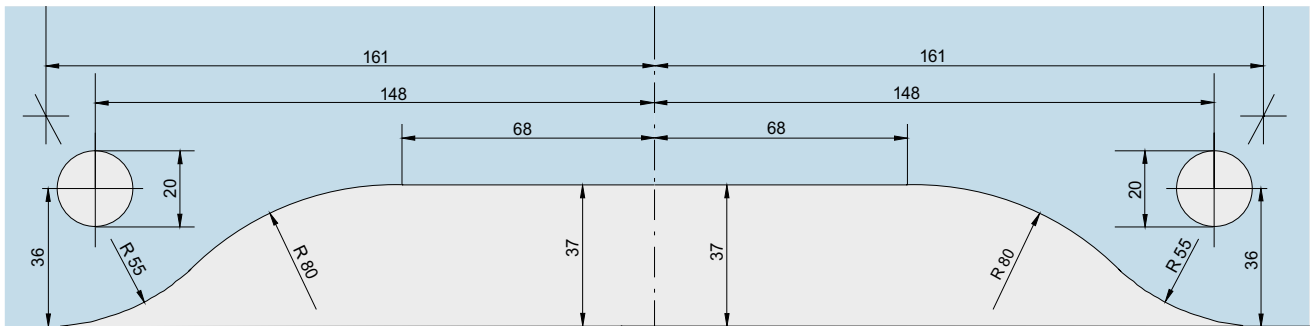

GK 20

Double overpanel
strike box
Art. No. 03.245,
03.247

Scale 1 : 2

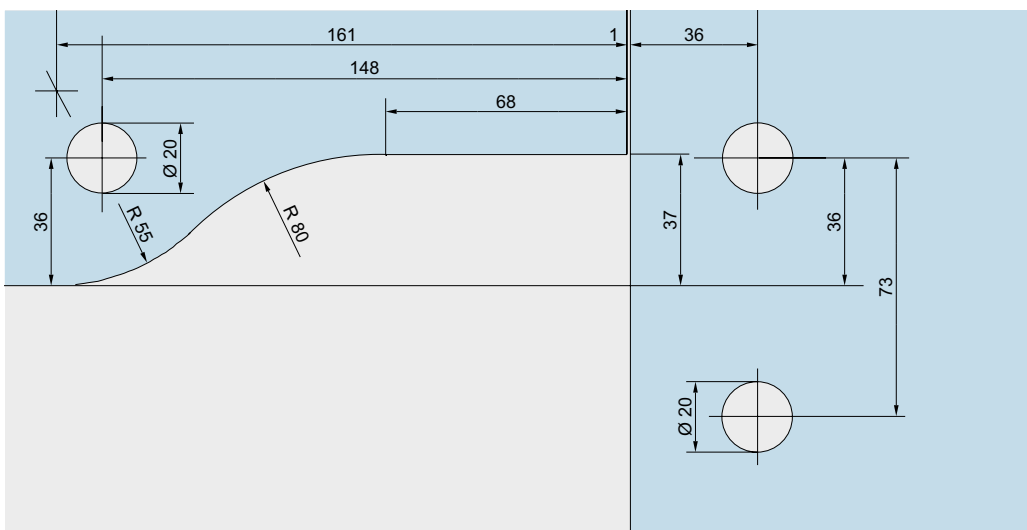

GK 40 (PT 40)

Corner overpanel
strike box
Art. No. 03.250,

Scale 1 : 2

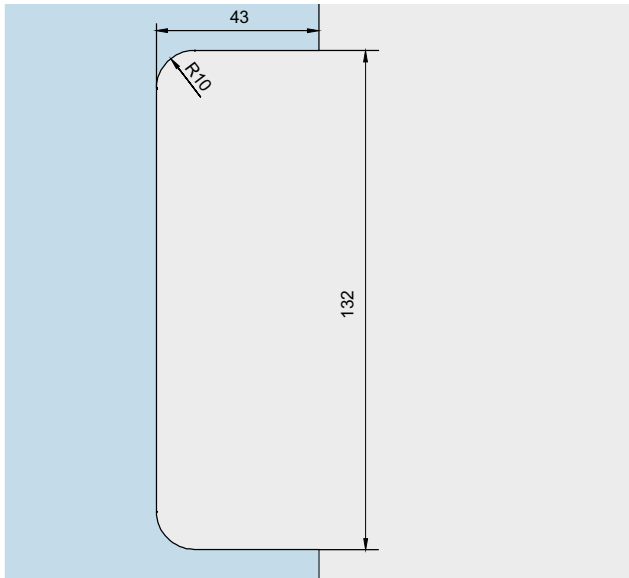
**US 20, GK 50**

Centre lock

Art. No. 03.215, 03.289, 03.290, 03.345

and strike box for centre lock

Art. No. 03.224

Scale 1 : 2

Glass preparation for corner, centre locks and strike boxes, requiring drilled holes

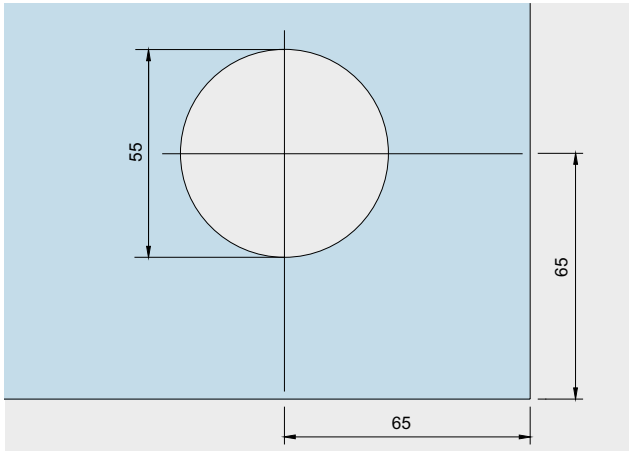

Corner locks

Art. No. 05.100, 05.103, 05.105, 05.116, 05.117, 05.118, 05.119

Scale 1 : 2

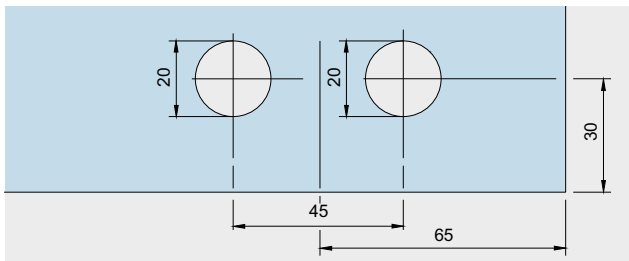

Strike boxes

Art. No. 05.108, 05.109

Scale 1 : 2

Glass preparation for centre locks and strike boxes, requiring drilled holes

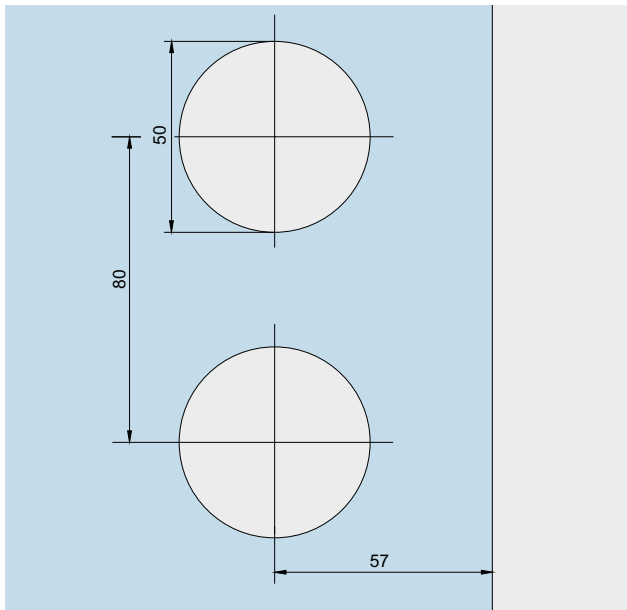

Centre locks

Art. No. 05.250, 05.251, 11.216, 11.217, 11.220, 11.221, 11.224, 11.225

Strike boxes for centre locks

Art. No. 05.252, 05.253, 11.206, 11.207

Scale 1 : 2

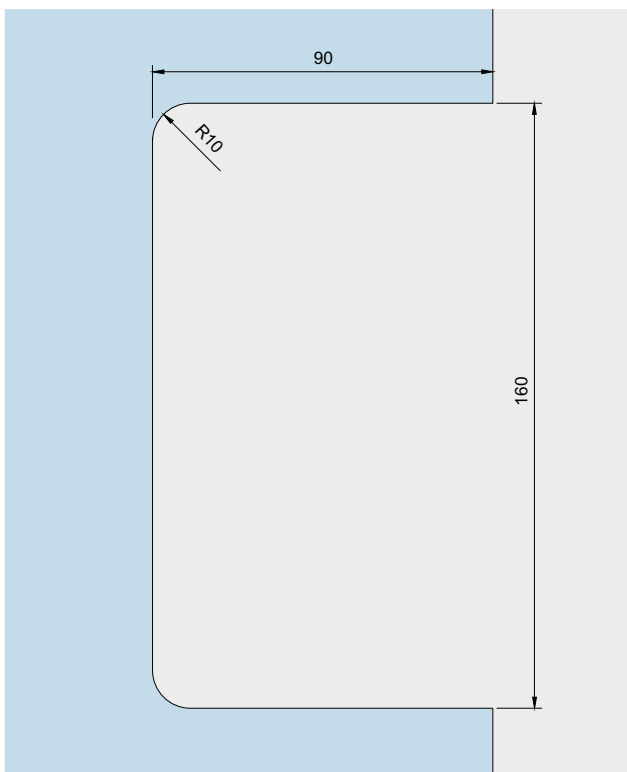

Centre locks with nightlatch function, hook bolts and strike boxes

Art. No. 05.200, 05.201, 05.202

Scale 1 : 2

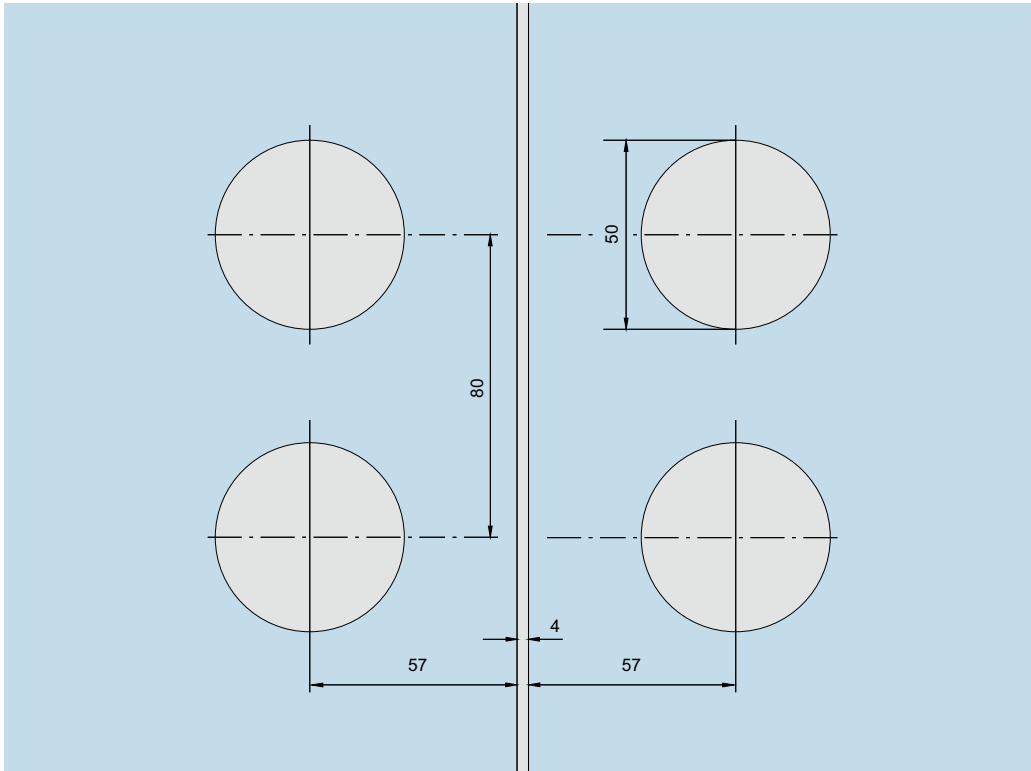

**Centre locks with
latch and lock
bolts, and strike
boxes**

Art. No. 05.224,
05.225, 05.226,
05.227, 05.240,
05.241, 05.244,
05.245, 05.250,
05.251, 05.252,
05.253

Scale 1 : 2

Space for your notes

Content

Wall connection profile

178	General information
179	Components
188	Accessories
212	Safety-related information



**Wall connection
profile**

Wall connection profiles

Consisting of: base profile, with bore holes (every 300 mm), incl. clamping parts with screws and gasket strips.

Application:

e. g. all around frame system for toughened glass assemblies, with fittings on sides and ceiling. The safety type prevents free hanging glass elements from falling down, by fixing the clamping fitting through glass holes. 15 kg load for each clamping part, torque for fixing screws 15 Nm (M 6 = Allan key size 4).

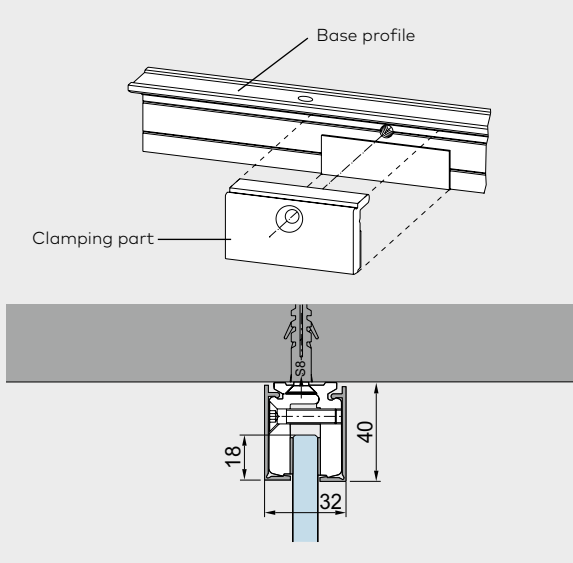
	Product description	Glass thickness	Art. No.
	Base profile 6,000 mm Stock length	8 mm 10 mm 12 mm 12.7 mm 13.5 mm 15 mm 17 mm 19 mm	07.042 07.001 07.002 07.045 07.046 07.047 07.048 07.049
	Fixed length	8 mm 10 mm 12 mm 12.7 mm 13.5 mm 15 mm 17 mm 19 mm	07.050 07.051 07.052 07.055 07.056 07.057 07.058 07.059
	Clamping part (addition/replacement) 60 mm long, with screws and gasket strips	8 mm 10 mm 12 mm 12.7 mm 13.5 mm 15 mm 17 mm 19 mm	07.043 07.004 07.005 07.085 07.086 07.087 07.088 07.089

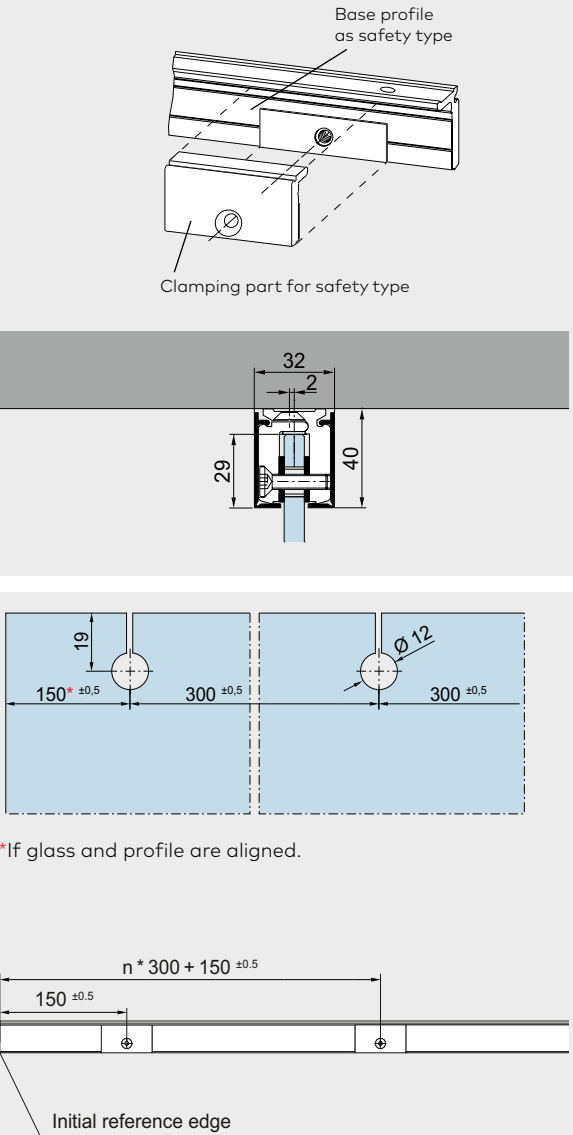
Safety type	Product description	Glass thickness	Art. No.	
	<p>Base profile as safety type 6,000 mm Stock length</p>	<p>8 mm 10 mm</p>	<p>07.060 07.061</p>	
	<p>Fixed length</p>	<p>8 mm 10 mm</p>	<p>07.066 07.067</p>	
	<p>Weight in kg/m: Aluminum 1.200</p>			
	<p>Clamping part (addition/replacement) for Safety type 60 mm long, with screws and gasket strips</p>	<p>8 mm 10 mm</p>	<p>07.063 07.064</p>	
	<p>Glass preparation for Safety type</p>			

*If glass and profile are aligned.

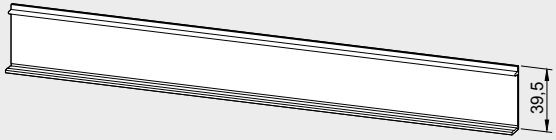
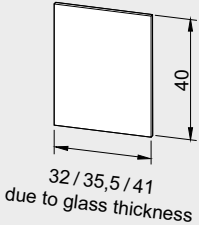
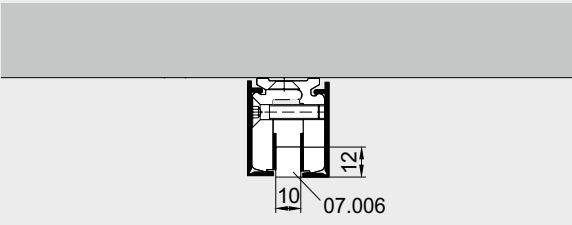
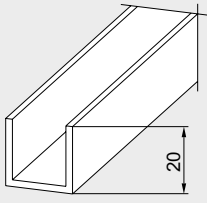
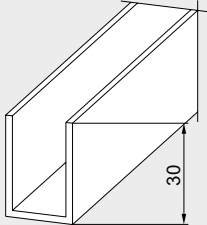
	Product description	Glass thickness	Art. No.
	<p>Clip on cover profile brass, stainless steel, satin and stainless steel polished door available</p> <p>Weight in kg/m: Aluminum 0.216 Stainless steel 0.366</p> <p>6,000 mm stock length fixed length</p>		<p>07.003 07.053</p>
	<p>End cap</p> <p>Weight in kg/pc: Aluminum 0.003 Brass 0.090 Stainless steel 0.090</p> <p>Aluminum 0.003 Brass 0.010 Stainless steel 0.010</p> <p>Aluminum 0.003 Brass 0.011 Stainless steel 0.012</p>	<p>8 mm and 10 mm</p> <p>12–13.5 mm</p> <p>15–19 mm</p>	<p>07.007</p> <p>07.044</p> <p>07.065</p>
	<p>Filler block, 10 x 12 mm</p> <p>6,000 mm stock length fixed length</p> <p>Weight in kg/m: Aluminum 0.325</p>		<p>07.006 07.054</p>
	<p>U-profile 20 x 20 x 20 x 2 mm</p> <p>6,000 mm stock length fixed length</p> <p>Weight in kg/m: Aluminum 0.304</p>		<p>07.092 07.093</p>
	<p>U-profile 30 x 20 x 30 x 2 mm</p> <p>6,000 mm stock length fixed length</p> <p>Weight in kg/m: Aluminum 0,304</p>		<p>07.097 07.096</p>

Space for your notes

Content

MR 22/MR 28

184 **Components**

188 **Accessories**

212 **Safety-related information**



MR 22/MR 28

Wall connecting frame system MR 22 and MR 28

Comprising a frame profile (series-drilled), a clamping profile and two contact rubber extrusions (PVC, grey).

These decorative and elegant frame solutions are characterised by their remarkably easy installation. The viewface width in the case of the MR 22 is a mere 22 mm and in the case of the MR 28 it is just 28 mm. Suitable for glass thicknesses of 8 and 10 mm. No load transfer by the profiles. Can be readily

removed and re-installed elsewhere. The MR 28 features an additional screw-fixing channel for connecting angle brackets and enables combination with mullion profiles for the vertical connection of several glass panels and also abutment to frame systems AT 44 and AT 50.

Applications:

e.g. surrounding frame for toughened glass systems for fixing to walls and ceilings

MR 22

max. glass dimensions:
height: 2,500 mm
width: 1,000 mm

MR 28

max. glass dimensions:
height: 2,800 mm
width: 1,000 mm

Base profile MR 22

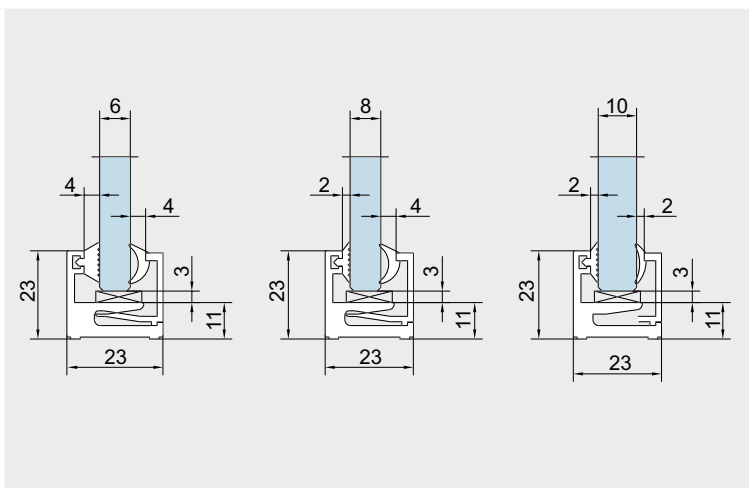
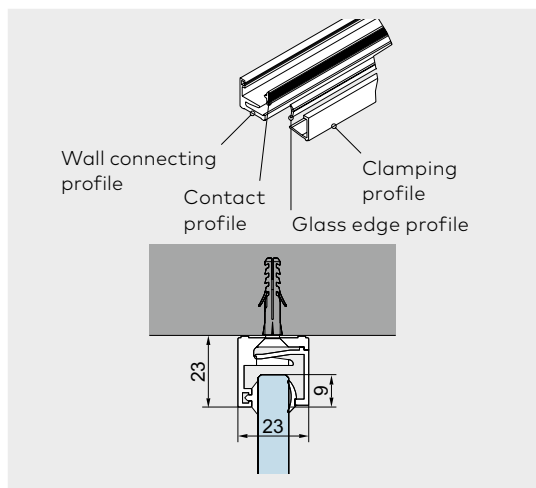

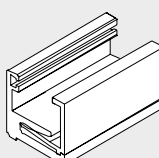
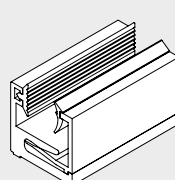
	Features and data	Art. No.
	<p>MR 22 in 6,000 mm stock length, without PVC profile</p> <p>Weight in kg/m: Aluminum 0.648</p>	07.240
	<p>MR 22 in fixed length</p> <p>Weight in kg/m: Aluminum 0.648</p>	07.250

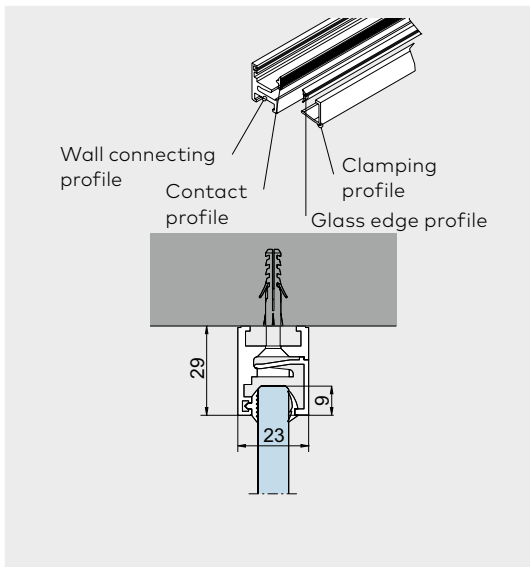
Base profile MR 28**Attention:**

Profiles are only delivered with straight cuts. Allowances in lengths of profiles to ensure producibility of bevel cuts have to be planned by the customer. The georgian bar profile must be prepared in addition on both sides. Please consider installation instruction

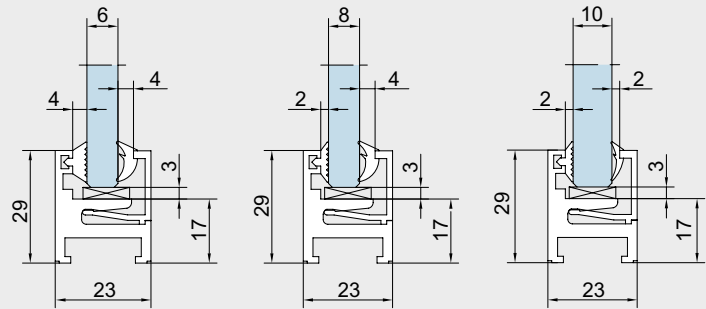
**Features and data****Art. No.**

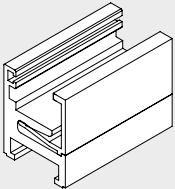
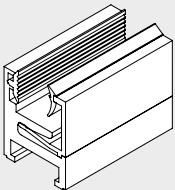
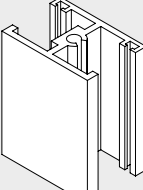
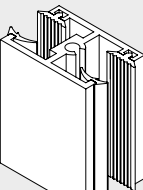
	<p>MR 28 in 6,000 mm stock length, without PVC profile</p> <p>Weight in kg/m: Aluminum 0.802</p>	07.241
	<p>MR 28 in fixed length</p> <p>Weight in kg/m: Aluminum 0.802</p>	07.251
	<p>Georgian bar profile MR 28 in 6,000 mm stock length, without PVC profile</p> <p>Weight in kg/m: Aluminum 0.542</p>	07.242
	<p>Georgian bar profile MR 28 in fixed length</p> <p>Screws for fixation at MR 28 base profile are not included in delivery. Recommendation: counter sunk screw 4.2 mm x 32 mm</p> <p>Weight in kg/m: Aluminum 0.542</p>	07.252

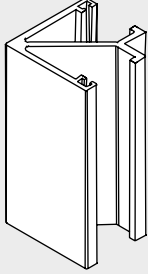
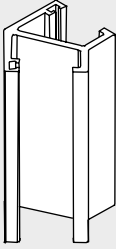
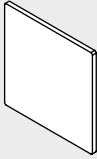
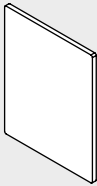
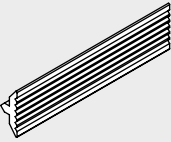
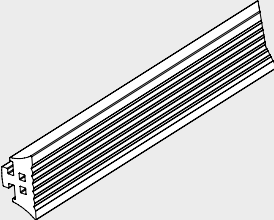
	Product description	Art. No.
	MR 28 georgian bar profile 90° in 6,000 mm stock length Weight in kg/m: Aluminum 0.598	07.258
	MR 28 georgian bar profile 135° in 6,000 mm stock length Weight in kg/m: Aluminum 0.466	07.259
	End mounted plate MR 22 Weight in kg/pc: Aluminum 0.002	07.245
	End mounted plate MR 28 Weight in kg/pc: Aluminum 0.002	07.246
	Contact profile 2 mm thick, grey fixed length stock length 50 m Weight in kg/m: PVC 0.023	07.255 07.265
	Contact profile 4 mm thick, grey fixed length stock length 50 m Weight in kg/m: PVC 0.037	07.256 07.266

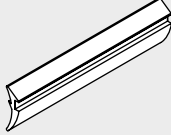
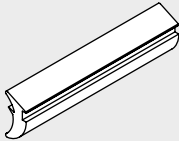
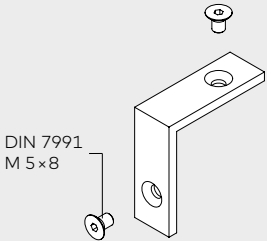
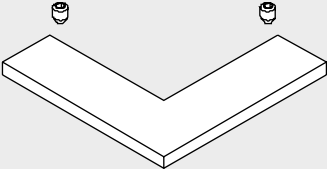
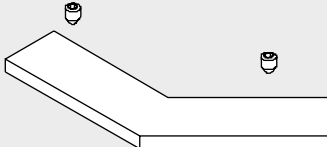
	Product description	Art. No.
	<p>Glass wedge profile 2 mm thick, grey</p> <p>fixed length stock length 50 m</p> <p>Weight in kg/m: PVC 0.016</p>	<p>07.253 07.263</p>
	<p>Glass wedge profile 4 mm thick, grey</p> <p>fixed length stock length 25 m</p> <p>Weight in kg/m: PVC 0.034</p>	<p>07.254 07.264</p>
 <p>DIN 7991 M 5 x 8</p>	<p>Corner connection set MR 28, 4 pieces per set</p> <p>8 screws DIN 7991 M 5 x 8 included in scope of delivery</p> <p>Weight in kg/pc: Aluminum 0.0021</p>	<p>07.247</p>
	<p>Corner connection for MR 28 georgian bar profil 90°</p> <p>2 grub screws DIN 916 M 4 x 5 included in scope of delivery</p>	<p>07.248</p>
	<p>Corner connection for MR 28 georgian bar profil 135°</p> <p>2 grub screws DIN 916 M 4 x 5 included in scope of delivery</p>	<p>07.249</p>

Content

Accessories

191	Top bearings, pivots
193	Floor bearings, lock keeper plate, floor sockets
194	Wall connection and cylinders
195	Profiles for UNIVERSAL
196	Gaskets
198	Clamping fittings
200	Accessories for door closer
204	Handle bars, door knobs, recessed pull grips
212	Safety-related information



Accessories

Perfection in detail

Original accessories for patch fittings, door rails and locks, matched to the dormakaba product range, are available.

They ideally complement the range of dormakaba hardware to optimise the technical excellence and cost effectiveness of toughened glass systems of all types.

Aside from functional components such as special floor pivots – including models for wet rooms – dormakaba also offers a choice of security-relevant options. Their installation further enhances the exceptional functional efficiency, reliability and long service life expected of dormakaba systems.

Top bearing, pivots for UNIVERSAL, BEYOND, EA, TP/TA, MANET

Advisory: Please note that the upper pivots for UNIVERSAL and those for MUNDUS are not mutually compatible. The spigot diameters of the MUNDUS fittings vary.

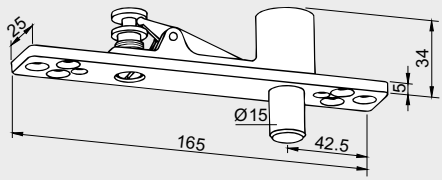
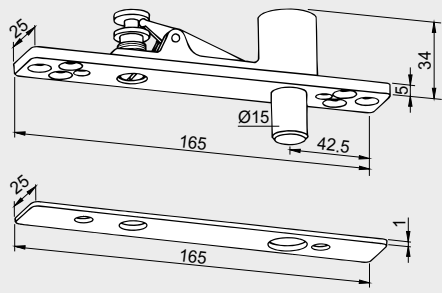
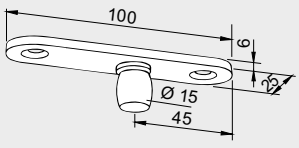
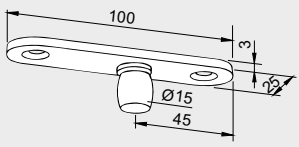
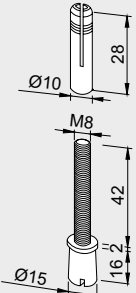
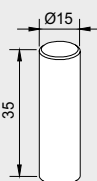
	Product description	Art. No.
	<p>PT 21 frame portion top centre with removable pin</p> <p>Weight in kg: 0.335</p> <p>15 mm Ø</p>	01.117
	<p>PT 21 frame portion top centre with removable pin, with cover plate</p> <p>Weight in kg: 0.345</p> <p>15 mm Ø</p>	01.118
	<p>PT 24 pivot with fixing plate, material thickness 6 mm, to let into ceiling</p> <p>Weight in kg: 0.058</p> <p>Aluminum</p> <p>15 mm Ø</p>	01.116
	<p>PT 24 pivot with fixing plate, material thickness 3 mm, to screw on the ceiling</p> <p>Weight in kg: 0.042</p> <p>Aluminum 0.074</p> <p>15 mm Ø</p>	01.123
	<p>PT 25 pivot with plug</p> <p>Weight in kg: 0.044</p> <p>15 mm Ø</p>	01.115
	<p>Loose pivot pin for interface between patch and rail</p> <p>Weight in kg: 0.050</p>	04.601

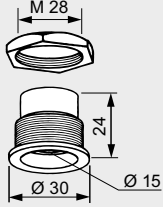
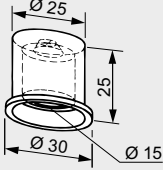
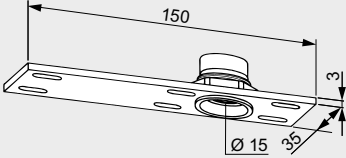
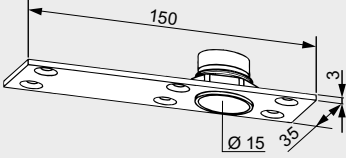
	Product description	Art. No.
	<p>Top pivot bearing, brass, nickel plated, for installation in frame or ceiling for 15 mm Ø pivot pin</p> <p>Weight in kg: 0.065</p>	<p>01.129</p>
	<p>Top pivot bearing aluminum, for installation in frame or ceiling for 15 mm Ø pivot pin</p> <p>Weight in kg: 0.018</p>	<p>01.130</p>
	<p>Top pivot bearing with steel fixing plate, for 15 mm Ø pivot pin</p> <p>Weight in kg: 0.160</p>	<p>01.131</p>
	<p>Top pivot bearing with aluminum fixing plate, for 15 mm Ø pivot pin</p> <p>Weight in kg: 0.099</p>	<p>01.132</p>

Floor bearing, lock keeper plate, floor socket for UNIVERSAL, BEYOND, EA, TP/TA, MANET

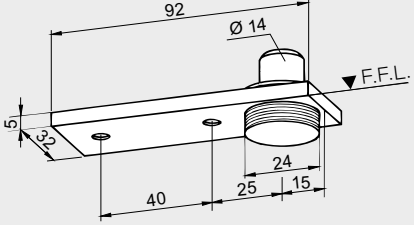
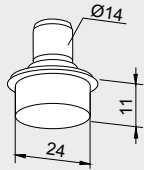
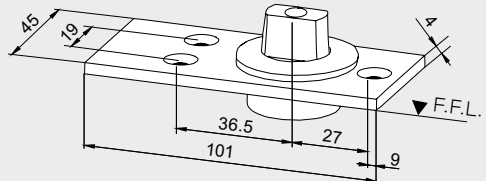
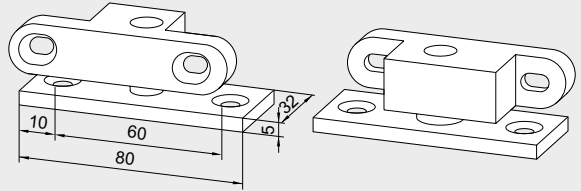
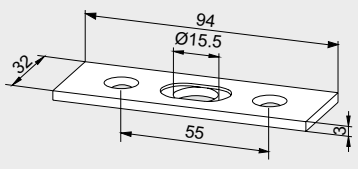
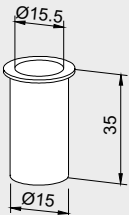
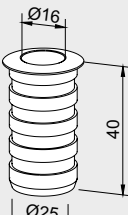
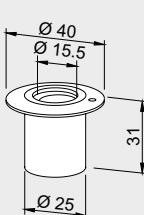
	Product description	Art. No.
	Floor pivot bearing with round pivot 14 mm Ø, and cover plate; height adjustable by 5 mm max. door weight 100 kg Weight in kg: Aluminum 0.155 Brass 0.170 Stainless steel 0.169	01.106
	Floor pivot bearing with round pivot 14 mm Ø and pin 24 mm Ø max. door weight 100 kg Weight in kg: 0.078	01.107
	Floor bearing with profile spindle (longer spindle on request), max. door weight 200 kg Stainless steel, max. door weight 200 kg Weight in kg: 0.254	04.602 04.603
	Floor pivot bearing for damp environments, with insert for UNIVERSAL PT 10 for mounting onto floor surface max. door weight 80 kg Weight in kg: 0.195	01.137
	Lock keeper plate, stainless steel, two parts, adjustable ± 5 mm Weight in kg: 0.048	05.190
	Floor socket, zinc coated brass for lock bolt Weight in kg: 0.020	05.192
	Floor socket, aluminum, with spring and plastic stopper, dirt protection Weight in kg: 0.026	05.193
	Eccentric socket, eccentric, zinc coated brass, with adjustable plastic socket insert Weight in kg: 0.020	05.194
05.192	05.193	05.194

Wall connection and cylinders for UNIVERSAL, BEYOND, EA, TP/TA, MANET

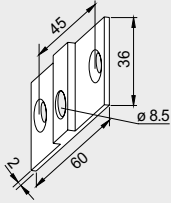
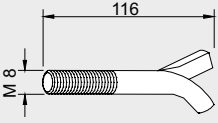
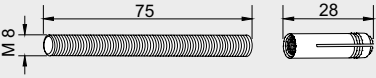
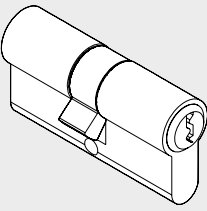
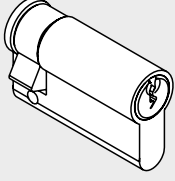
	Product description	Art. No.
	<p>Fixing plate for overpanel patches from UNIVERSAL, EP and EA program</p> <p>Weight in kg: Aluminum 0.019 Brass 0.045</p> <p>Stainless steel not available, satin chrome on brass supplied.</p>	01.127
	<p>Wall anchor for overpanel patches from UNIVERSAL, EP and EA program with thread M 8</p> <p>Weight in kg: 0.040</p>	01.133
	<p>Threaded rod for overpanel patches from UNIVERSAL, EP and EA program M 8 with plug</p> <p>Weight in kg: 0.032</p>	01.134
	<p>Profile cylinder length 61 mm, differently keyed, with Logo</p>	05.001
	<p>Profile cylinder length 61 mm, equally keyed, with Logo</p>	05.002
	<p>Half-profile cylinder length 31 mm, differently keyed, with Logo</p>	05.003
	<p>Half-profile cylinder length 31 mm, equally keyed, with Logo</p>	05.004

Profiles for UNIVERSAL

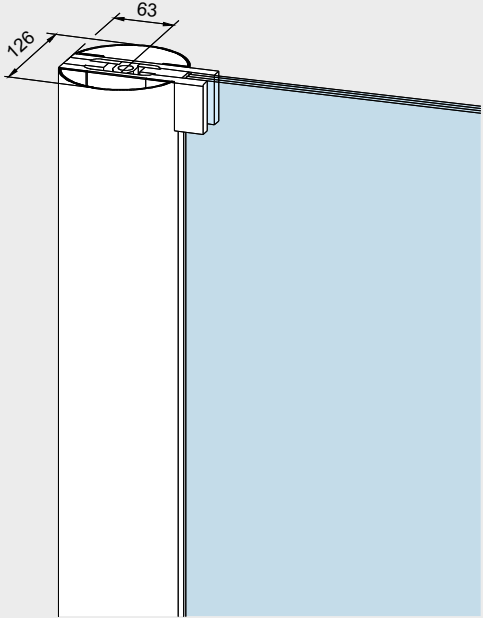
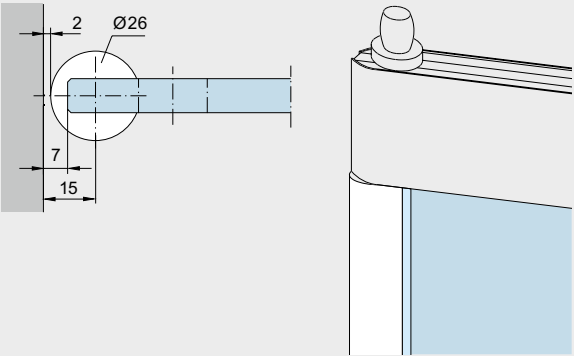
	Product description	Art. No.
	<p>Aluminum round profile for pinch free doors with 65 mm pivot point, consisting of 2 halves, prepared for UNIVERSAL fittings or door rails (76.5 mm or 100 mm).</p> <p>Please indicate:</p> <ul style="list-style-type: none"> • Panel height (max. 2,500 mm, higher dim. on request) • Required preparation of the profile for top and bottom fittings <p>Fixed length 03.380 Stock length 6,000 mm 03.381 Stock length 3,000 mm 03.382</p> <p>Weight in kg/m: Aluminum 4.744</p>	
	<p>Radiused edging strip for fittings with 15 mm/18 mm pivot point. For pinch free doors, (strip is clamped onto free glass edge), Acrylic.</p> <p>Length: up to 4,500 mm (specify height) 01.230 Length: 2,250 mm 01.231</p> <p>Weight in kg/m: 0.408</p>	

Gasket sets for UNIVERSAL

Product description	Art. No.	Product description	Art. No.
Gasket sets for 12 mm glass thickness		Gasket sets for 8 mm glass thickness	
for PT10/20/22/29/30/GK30	03.900	for PT10/20/22/29/30/GK30	03.920
for US 10/20/GK50	03.901	for US 10/20/GK50	03.921
for PT40/41/42/GK40/41/42	03.902	for PT40/41/42/GK40/41/42	03.922
for PT51	03.903	for PT51	03.923
for PT60/61/62	03.904	for PT60/61/62	03.924
for PT70/71	03.905	for PT70/71	03.925
for PT80/81	03.906	for PT80/81	03.926
for PT80 semi-high	03.907	for PT80 semi-high	03.927
for PT90/91	03.908	for PT90/91	03.928
for sidelight connector 01.153	03.909	for sidelight connector 01.153	03.929
for patch fitting 03.198	03.910	for patch fitting 03.198	03.930

Note: All fittings with a 15 mm pivot point are technically only designed for 10 mm glass thickness !

Space for your notes

Clamping fittings

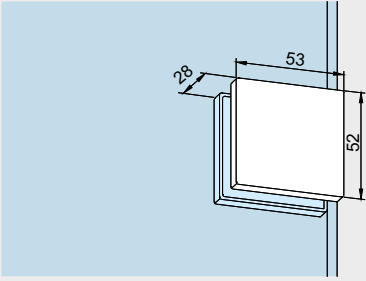
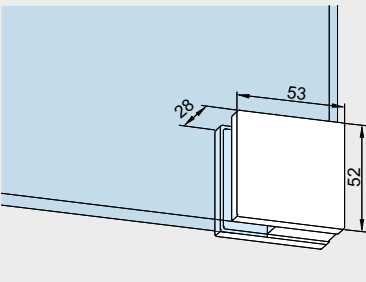
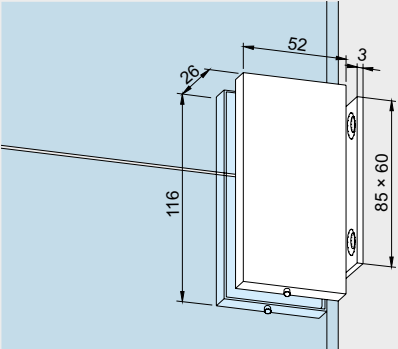
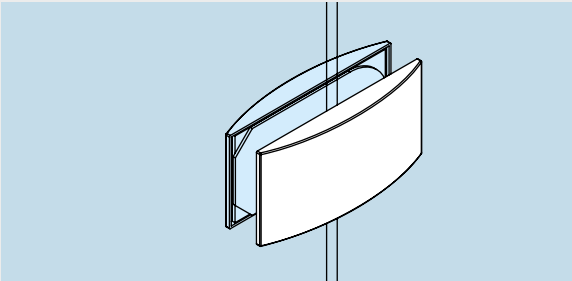
	Product description	Art. No.
	<p>PT 90 Srew on fitting</p> <p>Weight in kg: Aluminum 0.120 Brass 0.160 Stainless steel 0.155</p>	07.021
	<p>PT 91 corner fitting</p> <p>Weight in kg: Aluminum 0.120 Brass 0.160 Stainless steel 0.155</p>	07.023
	<p>Side connector with fixing plate</p> <p>Weight in kg: Aluminum 0.313 Stainless steel 0.376</p> <p>Also suitable for 12 mm glass thickness</p>	01.153
	<p>Overpanel-sidelight connector</p> <p>Weight in kg: Aluminum 0.146</p>	12.536

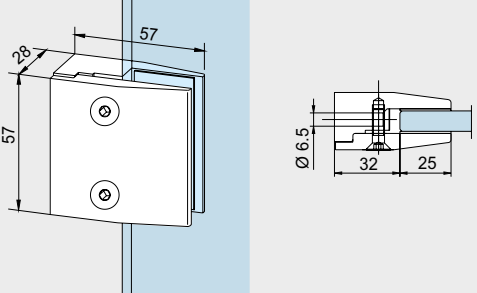
	Product description	Glass thickness	Art. No.
	Clamping fitting, aluminum, with passage hole for M 6 thread	8 mm	07.037
		10 mm	07.038
	Weight in kg: Aluminum 0.180	12 mm	07.039

Usage and assembly of fins

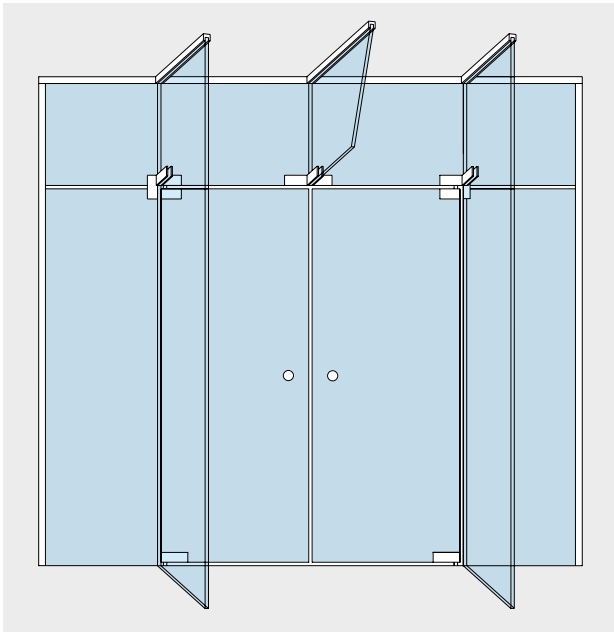

Fin fittings and corner connectors do not have a supporting structure. Overpanels, side-lights and fins have to be fixed securely to the ceiling by dormakaba wall connecting profiles or similar systems.

The need for stiffeners and the requisite glass thickness must be specified by a properly qualified structural engineer.

Accessories for door closer TS 73 V

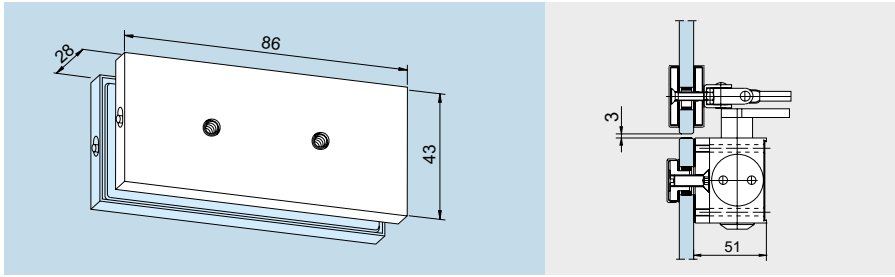

Fixing plate
for TS 73 V,
closer arm for overpanel

Art. No. 12.330

Weight in kg:
Aluminum 0.132

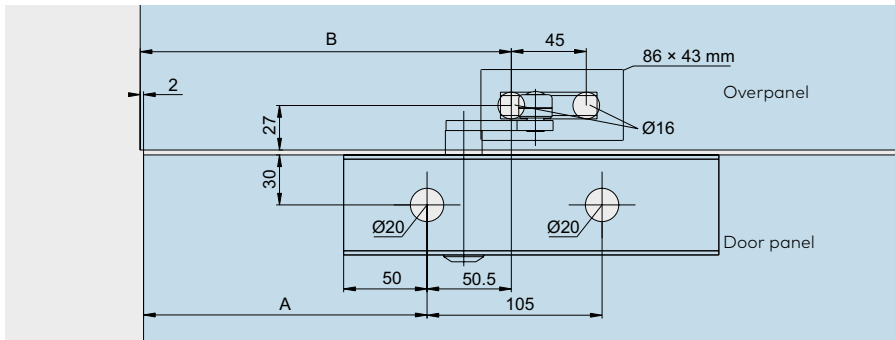

Pivot point fitting	A	B
EA (AT)	195	248
UNIVERSAL/EP/ MUNDUS	245	298
STUDIO/JUNIOR	170	223
UNIVERSAL Arcos	262	315

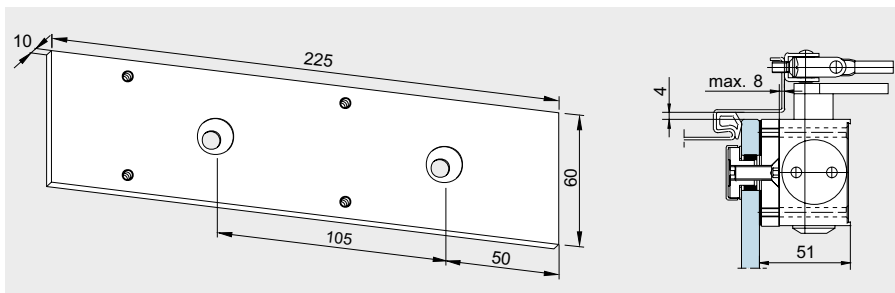

Fixing plate
225 mm,
for TS 73 V

Art. No. 12.335

Weight in kg
Aluminum 0.289

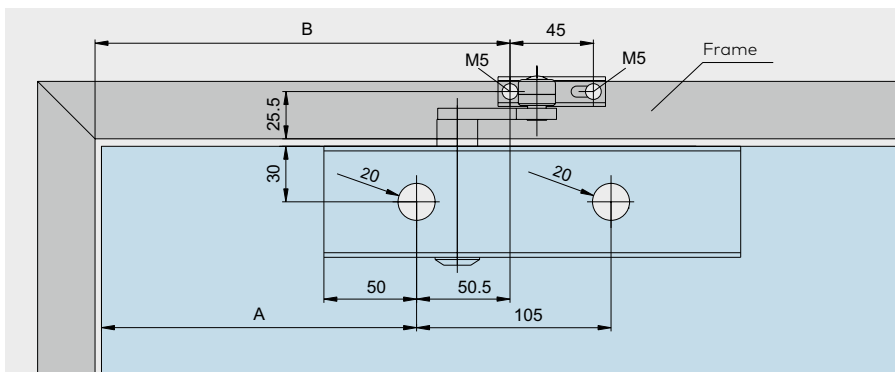

Pivot point fitting	A
EA (AT)	195
UNIVERSAL/EP/ MUNDUS	245
STUDIO/JUNIOR	170
UNIVERSAL Arcos	262

Accessories for door closer TS 92

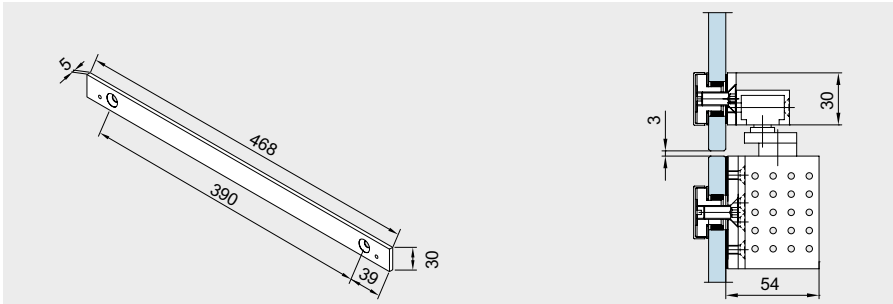

Fixing plate

for TS 92,
slide channel for overpanel

Art. No. 12.332

Weight in kg
Aluminum 0.265

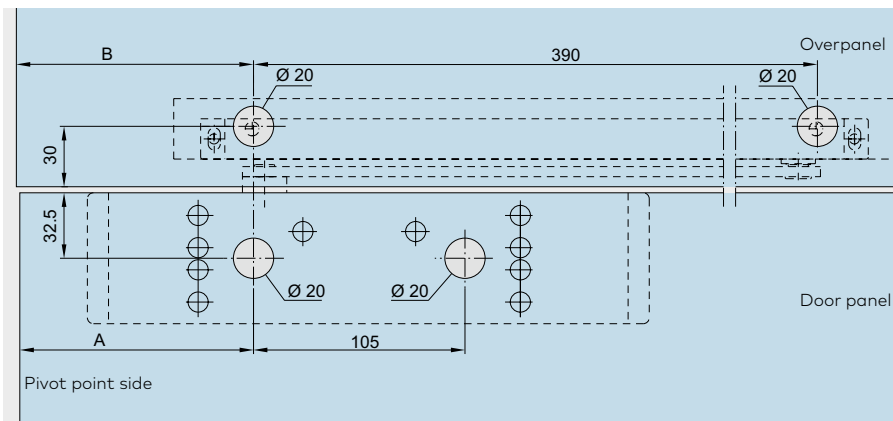

Drehpunkt-Beschlag	A	B
EA (AT)/EP	200	202
UNIVERSAL/ MUNDUS	250	252
STUDIO/JUNIOR	148	250
UNIVERSAL Arcos	265	267

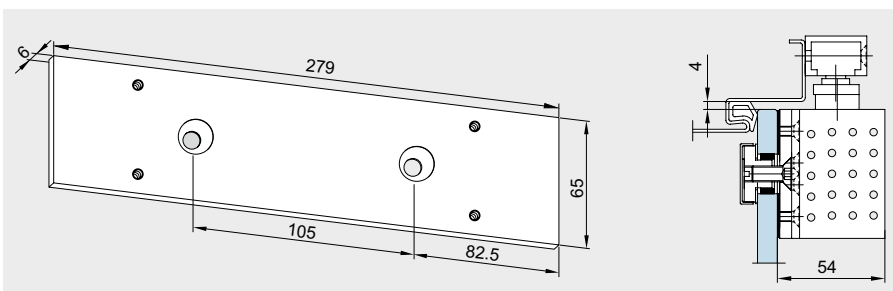

Fixing plate

279 mm,
for TS 92

Art. No. 12.334

Weight in kg:
Aluminum 0.290

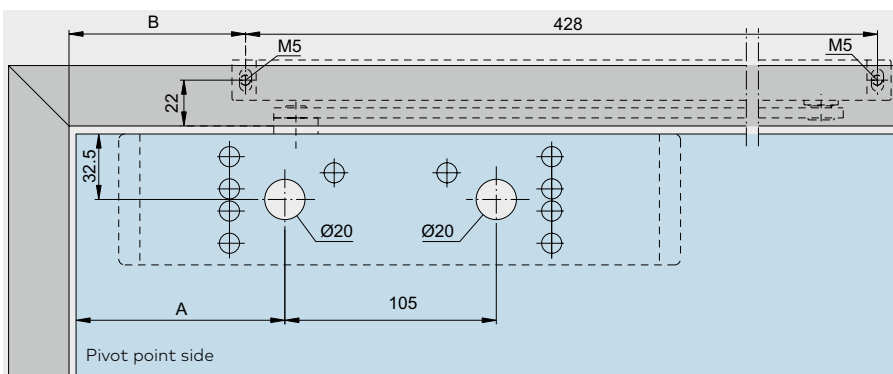

Drehpunkt-Beschlag	A
EA (AT)/EP	200
UNIVERSAL/ MUNDUS	250
STUDIO/JUNIOR	148
UNIVERSAL Arcos	265

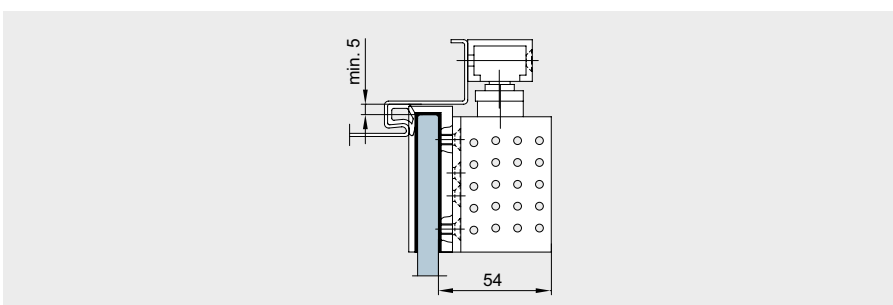

Saddle plate

and door closer TS 92 are available at dormakaba, Ennepetal, or at special suppliers for building hardware.

Door closer TS 97

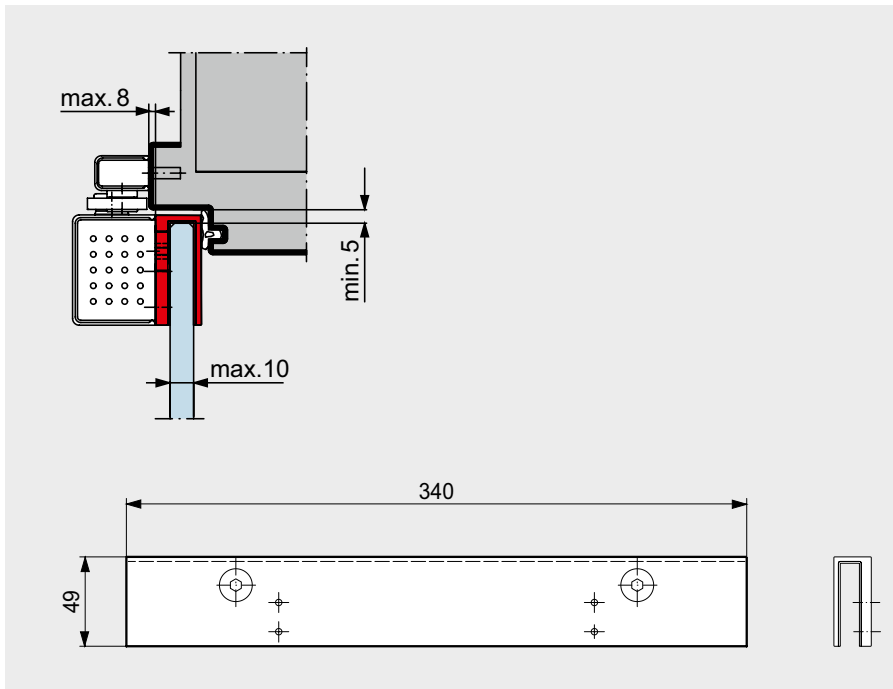

TS 97 including saddle plate

For connecting the closer to toughened glass doors – no glass recess machining or drilling required.

The TS 97 with this special glass fixing bracket should be used with STUDIO Arcos and OFFICE Arcos / OFFICE Junior hinges.

For more information please see our technical brochure TS 97.

Space for your notes

Pull handles, door knobs and recessed pull grip

The pull handle/knob system is designed for glass of 8, 10 and 12 mm thickness.

The pull handles can be fixed to both sliding and pivoting (swing) doors on one face using the appropriate connectors or on both faces by through-bolting (back-to-back arrangement).

Due to a flat structure recessed pull grips are also suitable for sliding doors.

The single-point fixings and through bolts are included as standard equipment in the scope of supply.

The pull handles can be fitted horizontally, vertically or in a handrail arrangement.



Pull handle pairs

	Product description	Glass thickness	Art. No.
	<p>Pair of handle bars satin stainless steel length 350 mm, 2 fixing points, weight in kg: 1.254 material 1.4305 do., material 1.4404</p> <p>Pair of handle bars aluminum length 350 mm, 2 fixing points, weight in kg: aluminum 1.326</p> <p>Pair of handle bars satin stainless steel length 720 mm, 2 fixing points, weight in kg: 1.947 material 1.4305 do., material 1.4404</p> <p>Pair of handle bars aluminum length 720 mm, 2 fixing points, weight in kg: aluminum 2.423</p>	<p>8/10/12 mm</p> <p>8/10/12 mm</p> <p>8/10/12 mm</p> <p>8/10/12 mm</p>	<p>21.267* 21.247</p> <p>03.400</p> <p>21.270* 21.250</p> <p>03.402</p>
	<p>Pair of handle bars satin stainless steel length 1,240 mm, 3 fixing points, weight in kg: 3.400 material 1.4305 do., material 1.4404</p> <p>Pair of handle bars satin stainless steel length 1,760 mm, 4 fixing points, weight in kg: 5.000 material 1.4305 do., material 1.4404</p>	<p>8/10/12 mm</p> <p>8/10/12 mm</p>	<p>21.273* 21.253</p> <p>21.276* 21.256</p>

* Conversion sets for back to back pull handles for timber doors resp. other glass thicknesses see unter "Spacing adjustment for pull handles and door knobs", page 207.

Pull handles single

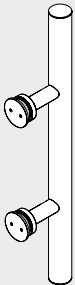
	Product description	Glass thickness	Art. No.	
	Pull handles with single-point fixings, countersunk Edelstahl Pull handle 350 mm with 2 fixings, material 1.4305 do., material 1.4404 Pull handle 720 mm with 2 fixings, material 1.4305 do., material 1.4404 Pull handle 1,240 mm with 3 fixings, material 1.4305 do., material 1.4404 Pull handle 1,760 mm with 4 fixings, material 1.4305 do., material 1.4404	8/10/12 mm	29.268 29.269 29.271 29.272 29.274 29.275 29.277 29.278	
		Pull handles with single-point fixings, clamping disc Pull handle 350 mm with 2 fixings, material 1.4305 do., material 1.4404 Pull handle 720 mm with 2 fixings, material 1.4305 do., material 1.4404 Pull handle 1,240 mm with 3 fixings, material 1.4305 do., material 1.4404 Pull handle 1,760 mm with 4 fixings, material 1.4305 do., material 1.4404	8/10/12 mm	21.240 21.241 21.281 21.242 21.243 21.283

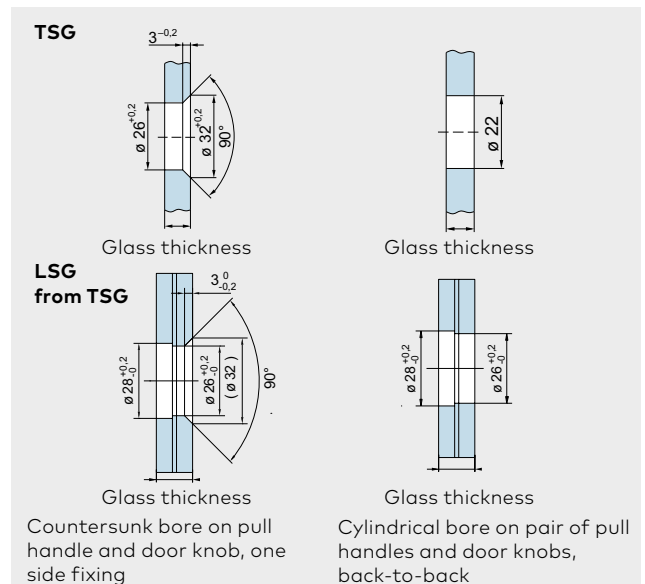
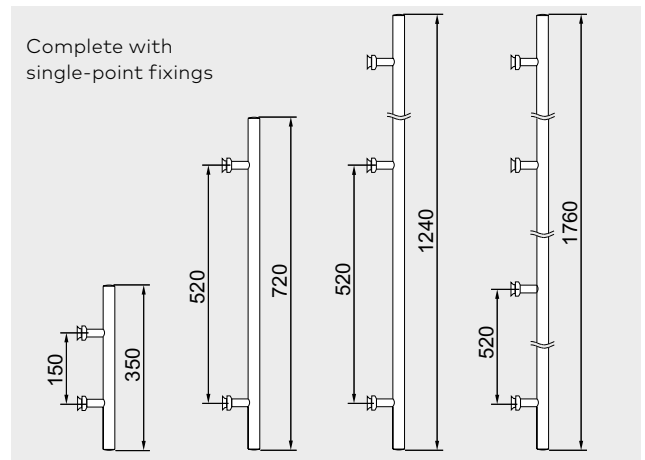
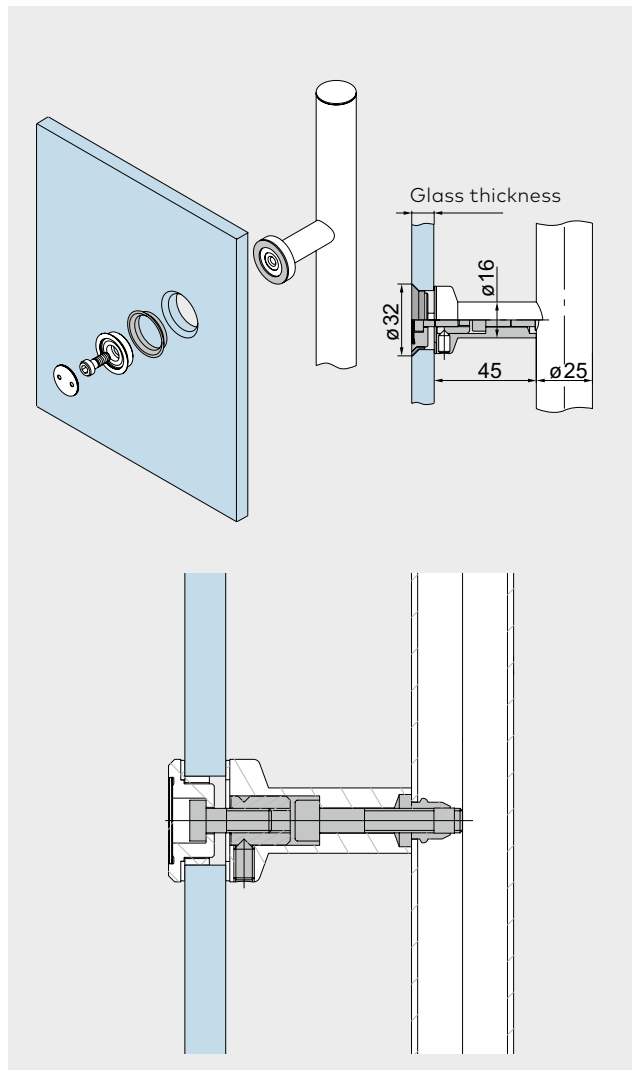

Spacing adjustment for pull handles and door knobs

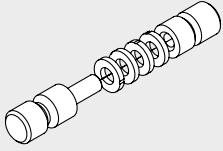
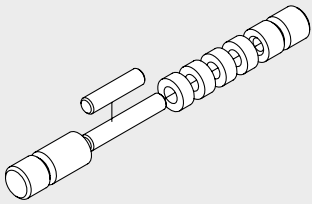
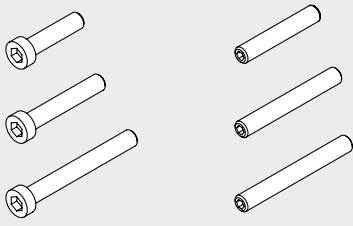
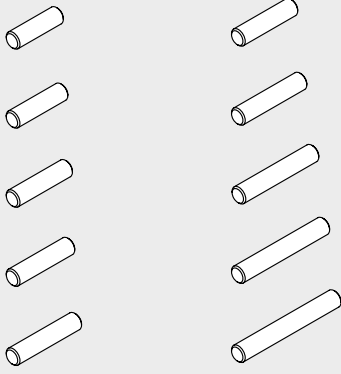
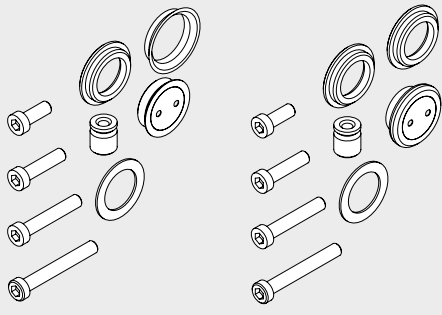
	Product description	Door thickness	Art. No.
 <p>Distance washer 2 mm</p>	<p>Conversion set 1 for glass doors, pair of pull handles / knob back-to-back</p> <p>without distance washer with 1 distance washer with 2 distance washers with 3 distance washers with 4 distance washers</p>	<p>13.5 – 21.5 mm</p> <p>13.5 mm 15 mm 17.5 mm 19 mm 21.5 mm</p>	21.285
 <p>Distance washer 5 mm</p>	<p>Conversion set 2 for timber doors, pair of pull handles / knob back-to-back</p> <p>without distance washer with 1 distance washer with 2 distance washers with 3 distance washers with 4 distance washers</p>	<p>20 – 40 mm</p> <p>20 mm 25 mm 30 mm 35 mm 40 mm</p>	21.286
 <p>Set 3 Set 4</p>	<p>Conversion set 3 for glass / timber doors*, pair of pull handles / knob back-to-back, countersunk 15 - 40 mm glass / timber thickness</p> <p>Conversion set 4 for glass / timber doors*, pair of pull handles / knob back-to-back, clamping disc 15 - 40 mm glass / timber thickness</p>		21.287 21.288
 <p>Set 5 Set 6</p>	<p>Conversion set 5 for glass doors*, recessed pull grip 13.5 - 21.5 mm glass thickness</p> <p>Conversion set 6 for timber doors*, recessed pull grip 20 - 40 mm timber thickness</p>		21.295 21.296
 <p>Set 7 Set 8</p>	<p>Conversion set 7 for glass / timber doors*, for pull handles fixed on both sides to pull handle fixed on one side, countersunk 8 - 40 mm glass / timber thickness 1 set per pull handle fixing</p> <p>Conversion set 8 for glass / timber doors*, for pull handles fixed on both sides to pull handle fixed on one side, clamping disc 8 - 40 mm glass / timber thickness 1 set per pull handle fixing</p>		21.297 21.298

*Not suitable for Arcos pull handles 26.500 / 26.510

Pair of pull handles

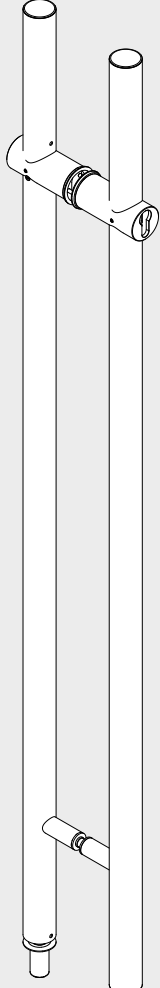
	Product description	Glass thickness	Art. No.
	Pair of stainless steel handlebars, lockable on both sides, prepared for standard PZ, length 1200 mm, incl. floor socket	8 - 17.5 mm	21.580
	Pair of stainless steel handlebars, lockable on one side, prepared for standard PZ, length 1200 mm, incl. floor socket	8 - 17.5 mm	21.581
<p>Further information, e.g. the required profile cylinder length, can be found in our detail on sheets 29-115 to 29-116.</p>			

Arcos pull handle

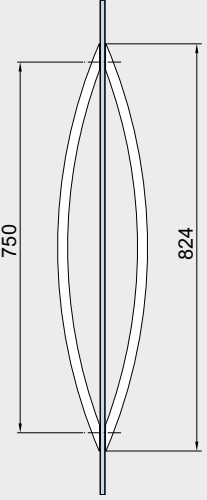
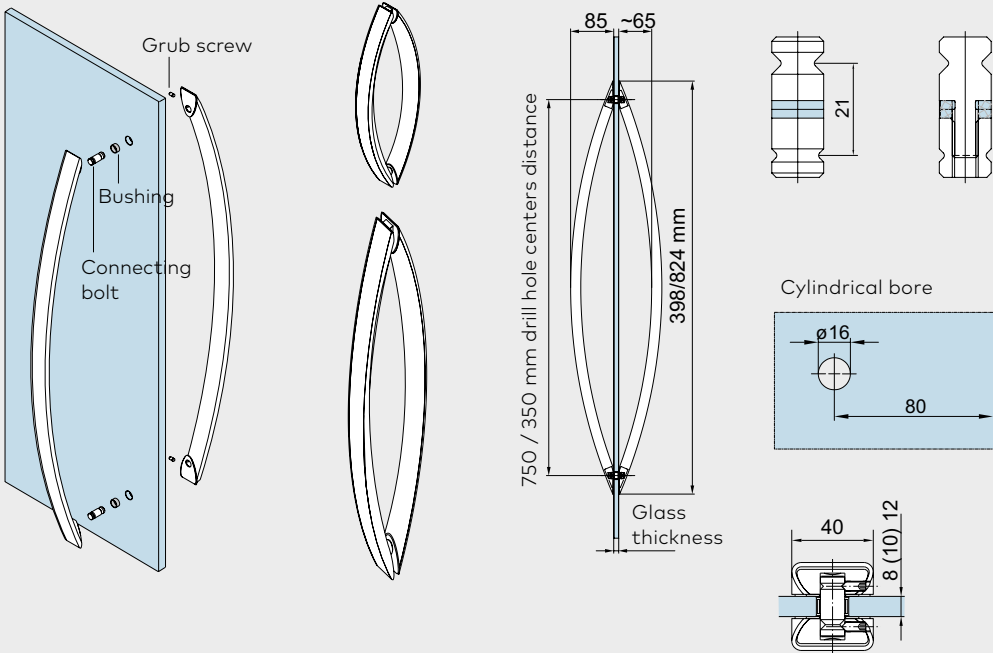
	Product description	Glass thickness	Art. No.
	<p>Arcos pair of pull handle incl. connecting bolt Aluminium, stainless steel look</p> <p>Pull handle 350 mm with 2 fixings Pull handle 750 mm with 2 fixings</p>	<p>8/10/12 mm</p>	<p>26.500 26.510</p>
			

Handle bars

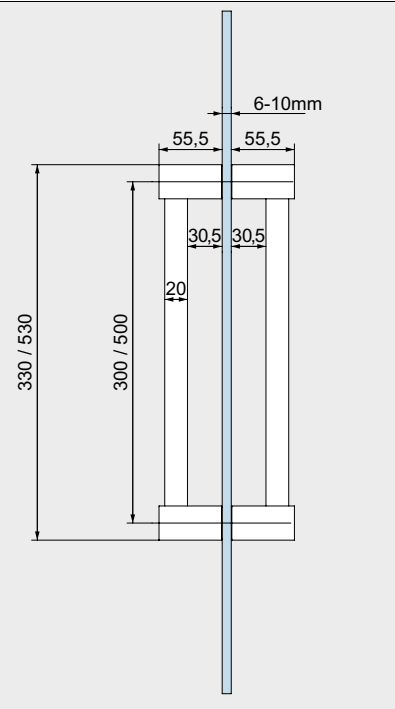
	Product description	Art. No.
	<p>Pull handle "Quadrat" Glas thickness 6 - 10 mm with 2 fixings Ø 12 mm</p> <p>Length 300 mm Length 500 mm</p>	<p>75.084 75.085</p>

Recessed pull grips and door knobs

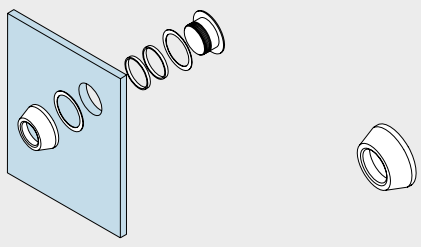
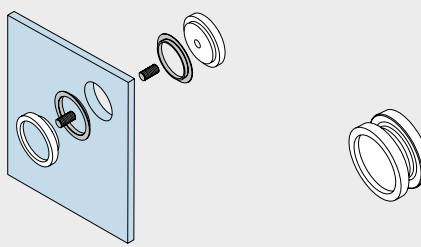
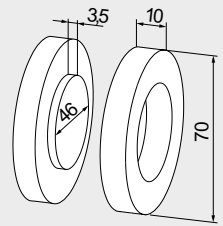
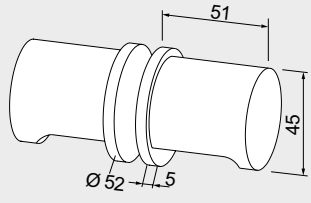
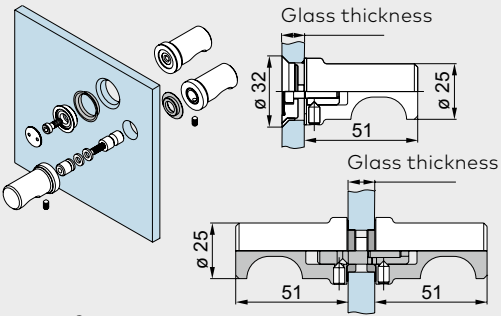
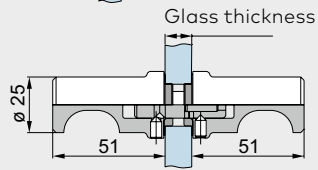
	Product description	Glass thickness	Art. No.
 <p>Ø 38 mm Glass bore</p>	<p>Recessed pull grip Ø 50 mm</p>	8/10/12 mm	21.290
 <p>Ø 50 mm Glass bore</p>	<p>Recessed pull grip Ø 60 mm</p> <p>Recessed pull grip with grip hole Ø 60 mm</p>	8/10/12 mm 8 mm 10 mm 12 mm	21.291 21.292 21.293 21.294
 <p>Ø 50 mm Glass bore</p>	<p>Recessed pull grip aluminum to be glued onto the glass Weight in kg: 0.072</p>		07.200
 <p>Ø 20 mm Glass bore</p>	<p>Door knob, aluminum Weight in kg: 0.400</p>		07.201
 <p>Single-point fixing clamping disc (Ø 22 mm)</p> <p>(Glass preparation please see under "pull handles single", page 206)</p>	<p>Door knob one side fixing Door knob with single-point fixing, countersunk Door knob with single-point fixings, clamping disc</p>	8/10/12 mm	21.422 21.426
	<p>Door knob back-to-back</p>	8/10/12 mm	21.423

Note: To ensure better load transmission, please use a pull handle in conjunction with the DORMOTION damping unit.

Safety-related information

Important safety-related information for the mounting and use of dormakaba glass fittings.

(Follow these instructions in addition to the mounting and operating instructions in order to avoid damage of product and damage to person or property.)

Important: All users have to be informed about relevant points mentioned in these safety-related information and the mounting and operating instructions!

General information

1. dormakaba recommends the use of TSG-H (heat-stored tempered safety glass) according to DIN EN 12150-1.
2. dormakaba glass fittings are not suitable for outdoor installation.
3. dormakaba glass fittings are not suitable for rooms where chemicals (e.g. chlorine) are used, e.g. swimming pools, saunas and brine baths.

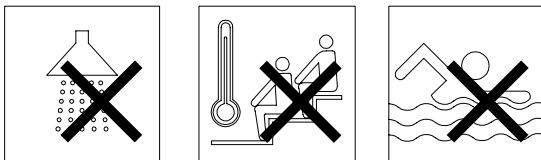

4. Sliding panels must not be moved faster than at walking speed and must be stopped by hand before reaching the end position will be.
5. Pivoting panels must not be thrown too hard. If there is a risk of over-turning, this must be prevented by a door stop.

Mounting

1. Only properly qualified and specially trained staff is authorised to mount dormakaba glass fittings.
2. Never use glass with conchoidal fractures and/or damaged edges.
3. Due to crushing hazards – among others in the area of the secondary closing edge – and possible injury caused by breakage of glass during mounting, corresponding protective clothing (especially gloves and protective goggles) is required.
4. Clean clamping area with fat solvent (standard commercial cleaning agent) before mounting the glass fitting.
5. Never use clamping shoes on structured glass surfaces (except on satined glass) or glass of heavily varying thickness unless with a corresponding levelling layer.
6. Never use clamping shoes on self-cleaning coatings.
7. When adjusting glass elements, always stick to the required clearance for the respective fitting. Adjust clearance so that the glass does not touch hard components such as glass, metal or concrete.
8. Make sure not to use excessive force when installing the glass (avoid local stress resulting from very tight screws).

Maintenance

Check fittings at regular intervals for proper positioning and smooth running and door for correct adjustment. Especially highly-frequented door systems require inspection by properly qualified staff (specialised companies or installation firms). Immediately replace damaged glass elements (no glass flaking and/or conchoidal fractures)!

General care instructions

The surface finishes of the fittings are not maintenance-free and should be cleaned according to their material and design.

- For metallic surfaces (anodised finishes, stainless steel) please use appropriate cleaning agents without abrasive additives only.
- For varnished surfaces please use appropriate solvent-free cleaning agents only.
- Brass surfaces (without surface protection) have to be treated with an appropriate maintenance agent on occasion, to avoid tarnishing.

For practical planning, please use our drawings dormakaba "The Detail".

The printed colours indicating the surface finishes are not 100 % true, but do provide a useful guide. Statements made with regard to the nature or use of the products are for the purposes of descriptions. Assent with regard to the existence of particular properties or particular uses always requires special written agreement. Pictures may show special designs which are different to the standard scope of delivery.

Subject to change without notice.

Our products



Interior Glass Systems

System solutions made from glass for a wide range of everyday and office applications



Mechanical Key Systems

Systems that enable access rights and key control to all rooms within the premises



Lodging Systems

Hotel locks and locking systems as well as access management solutions for holiday homes



Electronic Access & Data

Electronic access control and workforce management for efficient access management, security and data collection



Entrance Systems

Automated access solutions for convenient access to buildings



Door Hardware

Solutions for residential or commercial projects



Safe Locks

Security locks for preventing unauthorized access to goods, valuables, information or hazardous substances



Services

Tailor-made services and customized maintenance for long-term functional integrity of access and security solutions

